



**ATTUATORI ELETTRICI SERIE 85-86**  
**ELECTRIC ACTUATORS SERIES 85-86**



# APPROVAZIONI - APPROVALS

## ISO 9001 - ISO 14001 - ISO 50001 - OHSAS 18001



## ASSICURAZIONI - INSURANCE

L'intera gamma dei prodotti Valbia è coperta da assicurazione internazionale a tutela degli utilizzatori. I nostri servizi tecnici e commerciali sono a vostra completa disposizione.

The whole product range of Valbia is covered by international insurance for customer safety. Our technical and commercial service is at your disposal.

## CERTIFICAZIONI PRODOTTO - PRODUCT APPROVALS

Dichiarazione di conformità CE  
Declaration of Conformity CE

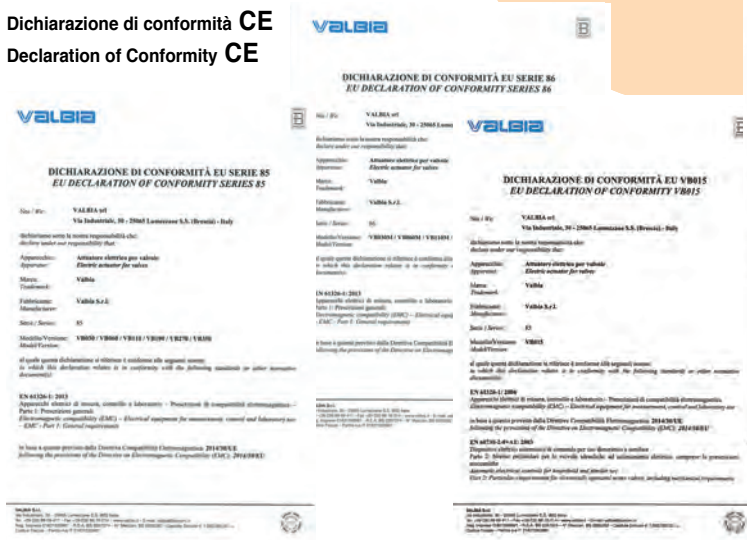

CSA In fase di certificazione - certification pending

Certificato RINA - Certificate RINA

UL attuatori elettrici  
UL electric actuators

## SPECIFICHE GENERALI

Valbia offre un'ampia gamma di attuatori elettrici monofase, 1/4 di giro, disponibili con diverse opzioni di alimentazione (vtaggio a 12V/24V/100-240V) e frequenza (50/60Hz), certificati CE, UL e con differenti gradi di protezione della custodia (IP-UL Type).

Gli attuatori elettrici Valbia sono ideati per l'automazione di una grande varietà di valvole a sfera e a farfalla per il settore industriale e civile, producendo un momento torcente che varia dai 15 ai 350 Nm.

Valbia seleziona, produce ed impiega componenti che assicurano un alto livello di qualità e dunque di performance:

- il circuito elettronico utilizza componenti di ultima generazione per garantire elevate prestazioni di controllo, permettendo, tra le altre cose, la regolazione automatica di velocità del motore al variare del carico mantenendo costante il tempo di rotazione dichiarato;
- il sistema elettronico per il controllo del momento torcente massimo (limitatore di coppia) e la resistenza di riscaldamento termostata, entrambi componenti di serie e sempre automaticamente operativi ad attuatore alimentato, garantiscono una costante protezione dell'attuatore;
- il cinematismo è composto da ruote dentate in acciaio ed in tecnopolimero, inserito in una struttura rigida in alluminio pressofuso sostenuta da alberi in acciaio montati su boccole autolubrificanti, per garantire un altissimo grado di resistenza della parte meccanica;
- gli attuatori sono dotati di piastra connessione ISO5211-DIN3337, doppia foratura, in alluminio pressofuso, verniciata, per consentire un collegamento veloce e diretto con la maggior parte delle valvole disponibili sul mercato.

Valbia realizza due serie di attuatori elettrici:

- la serie 85, con una custodia in tecnopolimero autoestinguente;
- la serie 86, con la custodia in alluminio pressofuso ricoperta in polvere di poliestere.

Oltre alle versioni standard, Valbia propone un'ampia gamma di versioni speciali atte a fornire soluzioni efficaci per ogni esigenza.

## GENERAL SPECIFICATIONS

Valbia provides a wide range of quarter-turn single-phase electric actuators, available with different voltages of power supply (12/24V/100-240V) and frequency (50/60 Hz), with CE and UL certifications and different level of protection enclosure (IP-UL Type).

VALBIA electric actuators are suitable for the automation of a great variety of ball and butterfly valves for the industrial and civil sector, with a torque valve that goes from 15 to 350 Nm.

Valbia selects, manufactures and uses high quality components to assure high performances:

- the electronic circuit uses last generation components to guarantee high control performances allowing, among other things, the motor speed automatic adjustment according to load variations, maintaining constant the declared working time.
- the electronic system for the control of the maximum torque (torque limiter) and the heater with the thermostat circuit, both included in the standard version and always automatically operating when the actuator is powered, ensure a constant protection of the actuator;
- the gear train is made of two steel and technopolymer gear wheels, inserted in a strong die-cast aluminum structure and sustained by hardened steel pinions mounted on self-lubricating bushes, to guarantee a very high resistance level of the mechanical part;
- the actuators are equipped with a die-cast and painted aluminum plate per ISO5211-DIN3337 standard, in order to allow a rapid and direct connection with most of the valves available on the market.

Valbia manufactures two series of electric actuators:

- the series 85, with a self-extinguish technopolymer enclosure;
- the series 86, with a die-cast aluminum enclosure coated with polyester powder.

In addition to the standard versions, Valbia offers a wide range of special versions designed to provide effective solutions for every need.

VERSIONI VERSION	TENSIONE VOLTAGE	VB015		VB030		VB060		VB110		VB190		VB270		VB350	
		85	86	85	86	85	86	85	86	85	86	85	86	85	86
ON/OFF	100-240V	•		•	•	•	•	•	•	•	•	•	•	•	•
	24V	•		•	•	•	•	•	•	•	•	•	•	•	•
	12V	•		•	•	•	•	•	•	•	•	•	•	•	•
BATTERIA BATTERY BACKUP	100-240V			•	•	•	•	•	•	•	•	•	•	•	•
	24V			•	•	•	•	•	•	•	•	•	•	•	•
	12V														
POSIZIONATORE POSITIONER	100-240V			•	•	•	•	•	•	•	•	•	•	•	•
	24V			•	•	•	•	•	•	•	•	•	•	•	•
	12V			•	•	•	•	•	•	•	•	•	•	•	•
POTENZIOMETRO POTENTIOMETER	100-240V			•	•	•	•	•	•	•	•	•	•	•	•
	24V			•	•	•	•	•	•	•	•	•	•	•	•
	12V			•	•	•	•	•	•	•	•	•	•	•	•
BATTERIA + POSIZIONATORE BATTERY BACKUP+ POSITIONER	100-240V			•	•	•	•	•	•	•	•	•	•	•	•
	24V			•	•	•	•	•	•	•	•	•	•	•	•
	12V														
POSIZIONE INTERMEDIA MIDDLE POSITION	100-240V			•	•	•	•	•	•	•	•	•	•	•	•
	24V			•	•	•	•	•	•	•	•	•	•	•	•
POSIZIONE INTERMEDIA + BATTERIA MIDDLE POSITION + BATTERY BACKUP	100-240V			•	•	•	•	•	•	•	•	•	•	•	•
	24V			•	•	•	•	•	•	•	•	•	•	•	•

**VERSIONI ATTUATORI ELETTRICI - ELECTRIC ACTUATORS VERSIONS****Standard con rotazione 0°-90°**

A richiesta disponibile anche, in versione speciale, con rotazione regolabile fino a 270°.

**Standard 0°-90° rotation**

Upon request also available with adjustable rotation up to 270°.

**Versione speciale con potenziometro 5K  $\Omega$  1 W @ 70°C**

Il potenziometro permette di ricevere un feedback remoto 5K  $\Omega$  1 W, resistivo, sulla posizione dell'attuatore anche quando quest'ultimo non è alimentato.

**Special version with potentiometer 5K  $\Omega$  1 W @ 70°C**

The potentiometer allows to receive a remote feedback 5K  $\Omega$  1 W, resistive, about the actuator position even when this is not powered.

**Versione speciale con posizionario std (4-20mA o 0-10 V) o reverse (20-4mA o 10-0V)**

La versione modulante può essere controllata tramite un comando di corrente (4-20mA) o di tensione (0-10V). Il controllo proporzionale presenta una banda morta pari al 1.44% del segnale analogico di comando ( $\pm 0.23$  mA /  $\pm 1.44$  V), con una tolleranza di posizionamento inferiore al 1% (riferito alla corsa massima del potenziometro).

**Special version with std (4-20mA o 0-10 V) or reverse (20-4mA o 10-0V) positioner**

The modulating version can be controlled by a current (4-20 mA) or voltage (0-10V) command. The proportional control presents a dead band equal to 1.44% of analogue control signal ( $\pm 0.23$  mA /  $\pm 1.44$  V), with a positioning tolerance of less than 1% (referring to the maximum potentiometer stroke).

**Versione speciale con batteria, per manovra di sicurezza**

Questa versione speciale è applicabile sia alla versione standard ON/OFF che a quella modulante con posizionario.

Il funzionamento a batteria viene immediatamente attivato non appena la tensione di alimentazione viene interrotta (e termina con la riattivazione della tensione di alimentazione); in questo caso la batteria muoverà l'attuatore in una delle seguenti modalità:

- per versione standard ON/OFF, apertura, chiusura o completamento della manovra comandata;
- per versione con posizionario, apertura o chiusura.

Le caratteristiche tecniche e le specifiche generali dell'attuatore sono quelle della versione di riferimento (ON/OFF o con posizionario).

**Special version with battery backup for fail-safe operation**

This special version is available for the ON/OFF standard version and with positioner.

Battery operation is immediately enabled, as soon as the voltage supply is interrupted (and it is stopped by the reactivation of the voltage supply); in such case the battery will operate the actuator in one of the following modes:

- for the ON/OFF standard version, open, close, ending the commanded operation;
- for the version with positioner, open or close.

Technical features and general specifications of the actuator as per reference version (ON/OFF or with positioner).

**Versione speciale con posizione intermedia - Versione standard 0° - 90° (a richiesta 0° - 180° / 0° - 270°)**

Questa versione è stata studiata per applicazioni speciali: è infatti possibile configurare 3 differenti posizioni di fine corsa, aperta, intermedia e chiusa.

**Special version with middle position - Standard version 0° - 90° (on request 0° - 180° / 0° - 270°)**

This version is designed for special applications: it allows to set up 3 different limit switch positions: open, intermediate and close.

Nel caso di applicazioni in ambienti soggetti a vibrazioni consultare l'ufficio commerciale.  
In use of installation in areas subject to vibrations, please contact our sales department.

VOLANTINO MANOVRA MANUALE  
 MANUAL HANDWHEEL

SCHEDA DI CONTROLLO  
 CONTROL BOARD

SCHEDA DI ALIMENTAZIONE  
 POWER SUPPLY BOARD

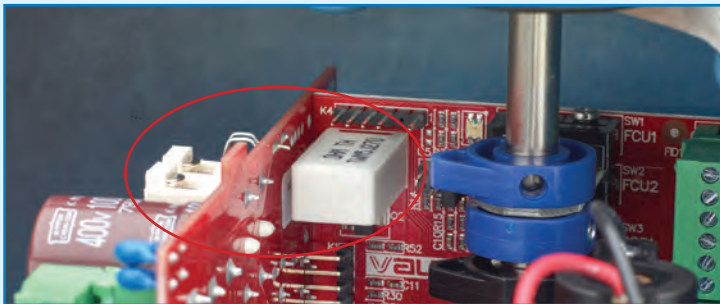

**RESISTENZA ANTICONDENSA:**  
 • Gestita dalla scheda di controllo per garantire una corretta temperatura interna.

**HEATING RESISTOR:**  
 • Managed by control board to guarantee the right internal temperature.





**CAMME DI POSIZIONE:**  
 • Camme nere: regolazione delle posizioni di finecorsa di apertura e chiusura.  
 • Camme blu: regolazione delle posizioni apertura e chiusura dei contatti puliti di finecorsa.

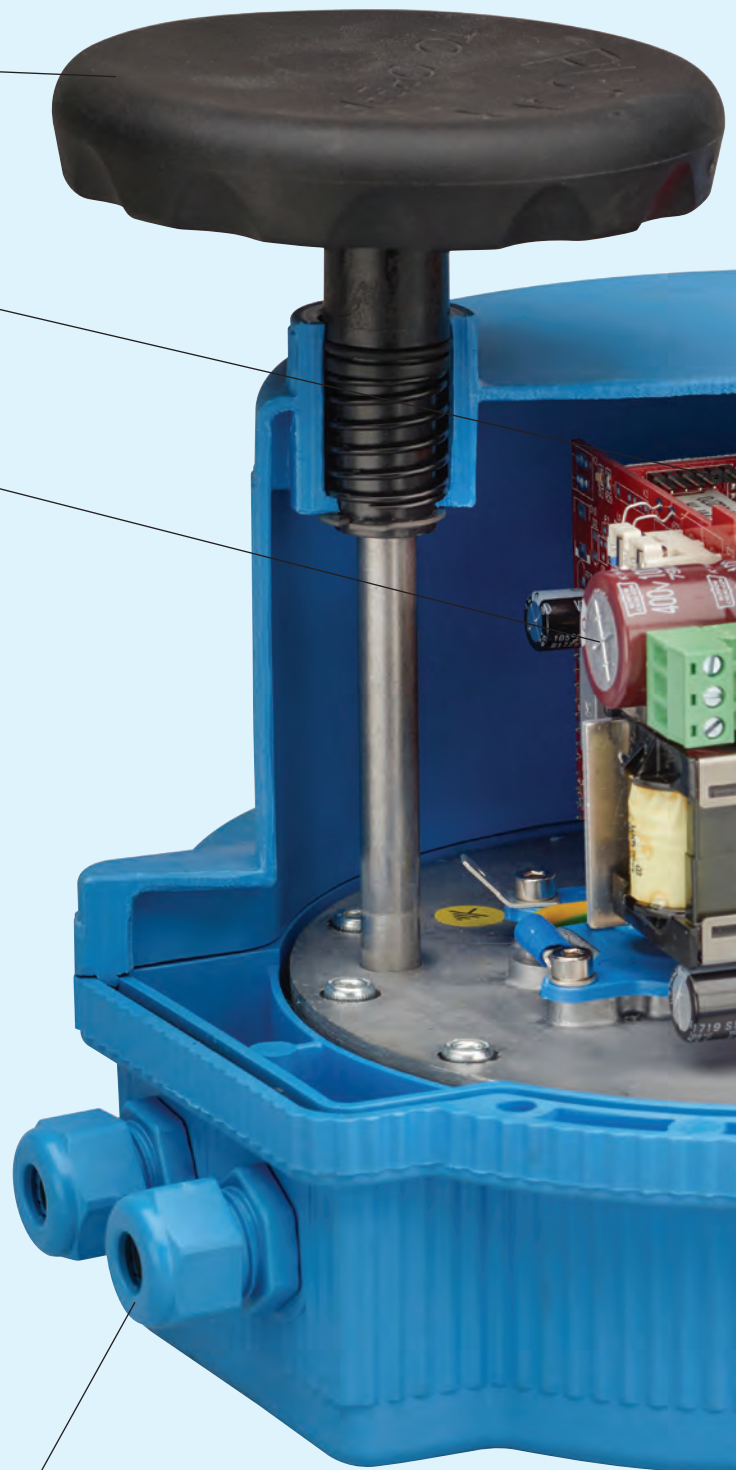

**POSITION CAMS:**  
 • Black cams: limit switches open and close adjustment.  
 • Blue cams: free limit switches open and close adjustment.

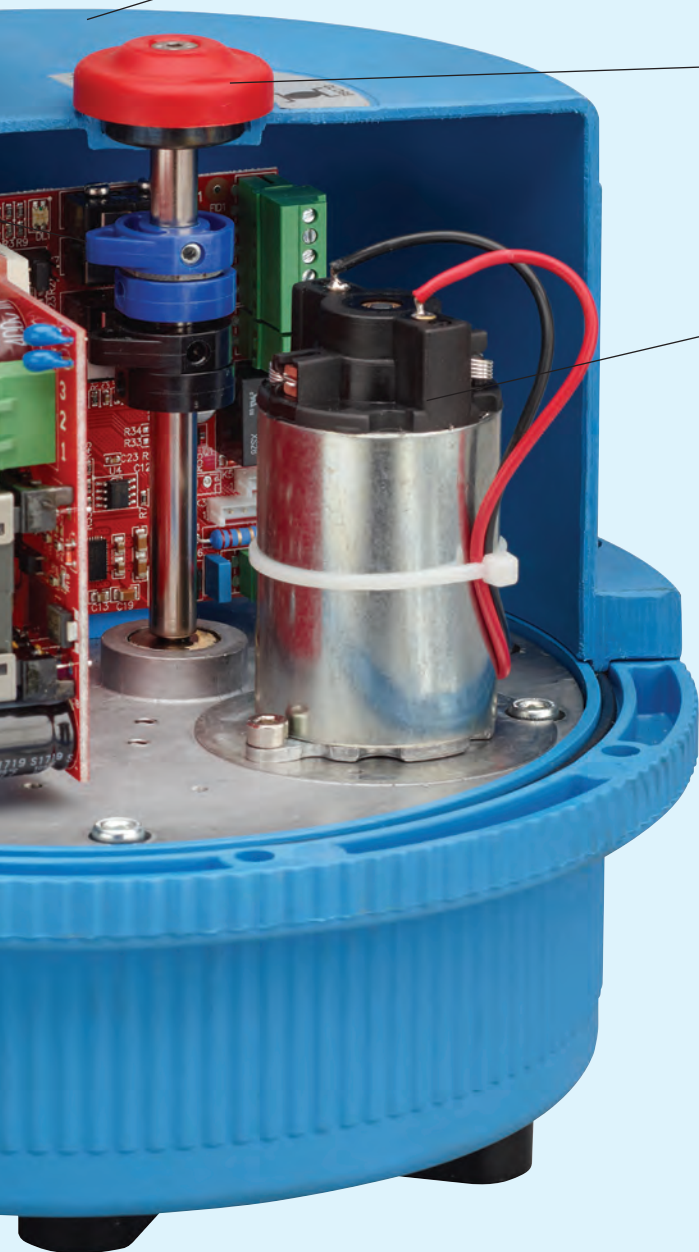

CONNESSIONI ELETTRICHE PG 11  
 PG 11 ELECTRIC CONNECTIONS







 CUSTODIA IN TECNOPOLIMERO AUTOESTINGUENTE (VO)  
 SELF-EXTINGUISH TECHNOPOLYMER ENCLOSURE

 INDICATORE DI POSIZIONE  
 POSITION INDICATOR

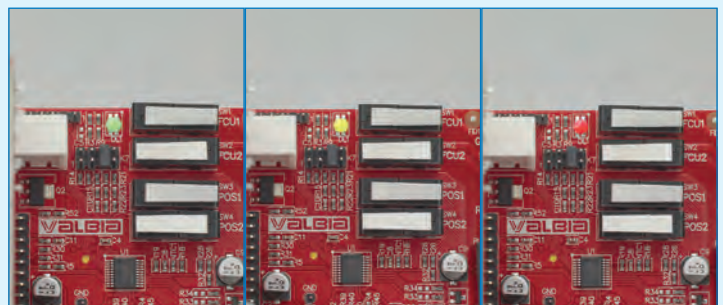
 MOTORE DC  
 DC MOTOR



 **LED luminosi per indicare:** alimentazione inserita (verde), stato funzionamento attuatore (giallo) e anomalia (rosso).

 **LED lights to indicate:** power supply ON (green), actuator working conditions (yellow) and fault (red).

**DATI TECNICI SERIE 85**  
**TECHNICAL DATA SERIES 85**

MODELLO - MODEL		VB015	VB030	VB060	VB110	VB190	VB270	VB350
MASSIMA COPPIA DI LAVORO (Nm) MAX WORKING TORQUE (Nm)		15	30	60	110	190	270	350
TENSIONE NOMINALE (V) NOMINAL TENSION (V)	BASSA TENSIONE - LOW VOLTAGE	12V AC/DC	12V AC/DC	12V AC/DC	12V AC/DC	12V AC/DC	12V AC/DC	12V AC/DC
		24V AC/DC	24V AC/DC	24V AC/DC	24V AC/DC	24V AC/DC	24V AC/DC	24V AC/DC
	MULTITENSIONE - MULTIVOLTAGE	100-240V AC	100-240V AC	100-240V AC	100-240V AC	100-240V AC	100-240V AC	100-240V AC
TEMPO DI MANOVRA (sec) - WORKING TIME (sec)		10	8	9	27	27	50	50
LIMITATORE DI COPPIA - TORQUE LIMITER		STD	STD	STD	STD	STD	STD	STD
DUTY RATING		12V AC/24V AC 50% 12V DC/24V DC 75%	12V AC/DC 50% 24V AC/DC 75%	12V AC/DC 50% 24V AC/DC 75%	12V AC/DC 50% 24V AC/DC 75%	12V AC/DC 50% 24V AC/DC 75%	12V AC/DC 50% 24V AC/DC 75%	12V AC/DC 50% 24V AC/DC 75%
PROTEZIONE - PROTECTION		IP65	IP67	IP67	IP67	IP67	IP67	IP67
CUSTODIA-ENCLOSURE		TECNOPLIMERO TECHNOPOLYMER	TECNOPLIMERO TECHNOPOLYMER	TECNOPLIMERO TECHNOPOLYMER	TECNOPLIMERO TECHNOPOLYMER	TECNOPLIMERO TECHNOPOLYMER	TECNOPLIMERO TECHNOPOLYMER	TECNOPLIMERO TECHNOPOLYMER
ROTAZIONE - ROTATION		90°	90°	90°	90°	90°	90°	90°
ROTAZIONE A RICHIESTA - UPON REQUEST ROTATION		180°	180° or 270°	180° or 270°	180° or 270°	180° or 270°	180° or 270°	180° or 270°
COMANDO EMERGENZA MAN. - MANUAL OVERRIDE		STD	STD	STD	STD	STD	STD	STD
INDICATORE DI POSIZIONE - POSITION INDICATOR		STD	STD	STD	STD	STD	STD	STD
TEMPERATURA DI UTILIZZO - WORKING TEMPERATURE		-20°C + 55°C	-20°C + 55°C	-20°C + 55°C	-20°C + 55°C	-20°C + 55°C	-20°C + 55°C	-20°C + 55°C
RESISTENZA ANTICONDENSA - HEATER		STD	STD	STD	STD	STD	STD	STD
FINECORSA AGGIUNTIVI - ADDITIONAL FREE LIMIT SWITCHES		n°2 STD (type SPDT)	n°2 STD (type SPDT)	n°2 STD (type SPDT)	n°2 STD (type SPDT)	n°2 STD (type SPDT)	n°2 STD (type SPDT)	n°2 STD (type SPDT)
FORATURA ISO 5211 - DRILLING ISO 5211		*F03 - F05	*F03 - F05	F05 - F07	F07 - F10	F07 - F10	F07 - F10	F07 - F10
QUADRO (mm) - SQUARE (mm)		11	11	14	17	17	22	22
QUADRO A RICHIESTA (mm) - SQUARE UPON REQUEST (mm)		9	9-14	11-17	14-22	14-22	17	17
ALIMENT. MANOVRA DI SICUREZZA FAIL-SAFE OPERATION (BATTERY BACKUP)		NON FORNIBILE NOT AVAILABLE	A RICHIESTA UPON REQUEST	A RICHIESTA UPON REQUEST	A RICHIESTA UPON REQUEST	A RICHIESTA UPON REQUEST	A RICHIESTA UPON REQUEST	A RICHIESTA UPON REQUEST
POSIZIONATORE STD (4~20mA or 0~10 VDC) REVERSE (20~4mA or 10~0 VDC) STD (4~20mA or 0~10 VDC) REVERSE (20~4mA or 10~0 VDC) MODE POSITIONER		NON FORNIBILE NOT AVAILABLE	A RICHIESTA UPON REQUEST	A RICHIESTA UPON REQUEST	A RICHIESTA UPON REQUEST	A RICHIESTA UPON REQUEST	A RICHIESTA UPON REQUEST	A RICHIESTA UPON REQUEST
POSIZIONE INTERMEDIA - MIDDLE POSITION		NON FORNIBILE NOT AVAILABLE	A RICHIESTA UPON REQUEST	A RICHIESTA UPON REQUEST	A RICHIESTA UPON REQUEST	A RICHIESTA UPON REQUEST	A RICHIESTA UPON REQUEST	A RICHIESTA UPON REQUEST
POTENZIOMETRO ROTATIVO (5K Ω 1W) (@ 70°C) ROTARY POTENTIOMETER (5K Ω 1W) (@ 70°C)		NON FORNIBILE NOT AVAILABLE	A RICHIESTA UPON REQUEST	A RICHIESTA UPON REQUEST	A RICHIESTA UPON REQUEST	A RICHIESTA UPON REQUEST	A RICHIESTA UPON REQUEST	A RICHIESTA UPON REQUEST
CONNESSIONI ELETTRICHE - ELECTRICAL CONNECTIONS		PG11	PG11	PG11	PG11	PG11	PG11	PG11
PESO (Kg) - WEIGHT (Kg)		1.40	2.30	3.30	4.90	4.90	6.00	6.00

\* A richiesta F04 o F07 - F04 or F07 upon request

**DATI DI CONSUMO ATTUATORE ELETTRICO - ELECTRIC ACTUATOR CONSUMPTION DATA**

MODELLO - MODEL		VB015	VB030	VB060	VB110	VB190	VB270	VB350					
VERSIONE H VERSION H	TENSIONE NOMINALE NOMINAL VOLTAGE	100-240V AC											
	CORRENTE ASSORBITA ABSORBED CURRENT	0,3-0,19 A	0,4-0,2 A	0,6-0,3 A	0,4-0,2 A	0,6-0,3 A	0,6-0,3 A	0,75-0,4 A					
	POTENZA ASSORBITA ABSORBED POWER	30-46 VA	40-48 VA	60-72 VA	40-48 VA	60-72 VA	60-72 VA	75-96 VA					
VERSIONE L VERSION L	TENSIONE NOMINALE NOMINAL VOLTAGE	12V AC/DC	24V AC/DC	12V AC/DC	24V AC/DC	12V AC/DC	24V AC/DC	12V AC/DC	24V AC/DC				
	CORRENTE ASSORBITA ABSORBED CURRENT	1,2 A	0,6 A	2,2-1,8 A	1,0-0,7 A	3,8-2,85 A	1,8-1,2 A	2,2-1,8 A	1,0-0,7 A	3,8-2,85 A	1,8-1,2 A	4,75-3,65 A	1,95-1,65 A
	POTENZA ASSORBITA ABSORBED POWER	15 VA	26,5-22 VA	24-17 VA	46-34 VA	43-29 VA	26,5-22 VA	24-17 VA	46-34 VA	43-29 VA	46-34 VA	43-29 VA	57-44 VA
FREQUENZA FREQUENCY		50/60 HZ											

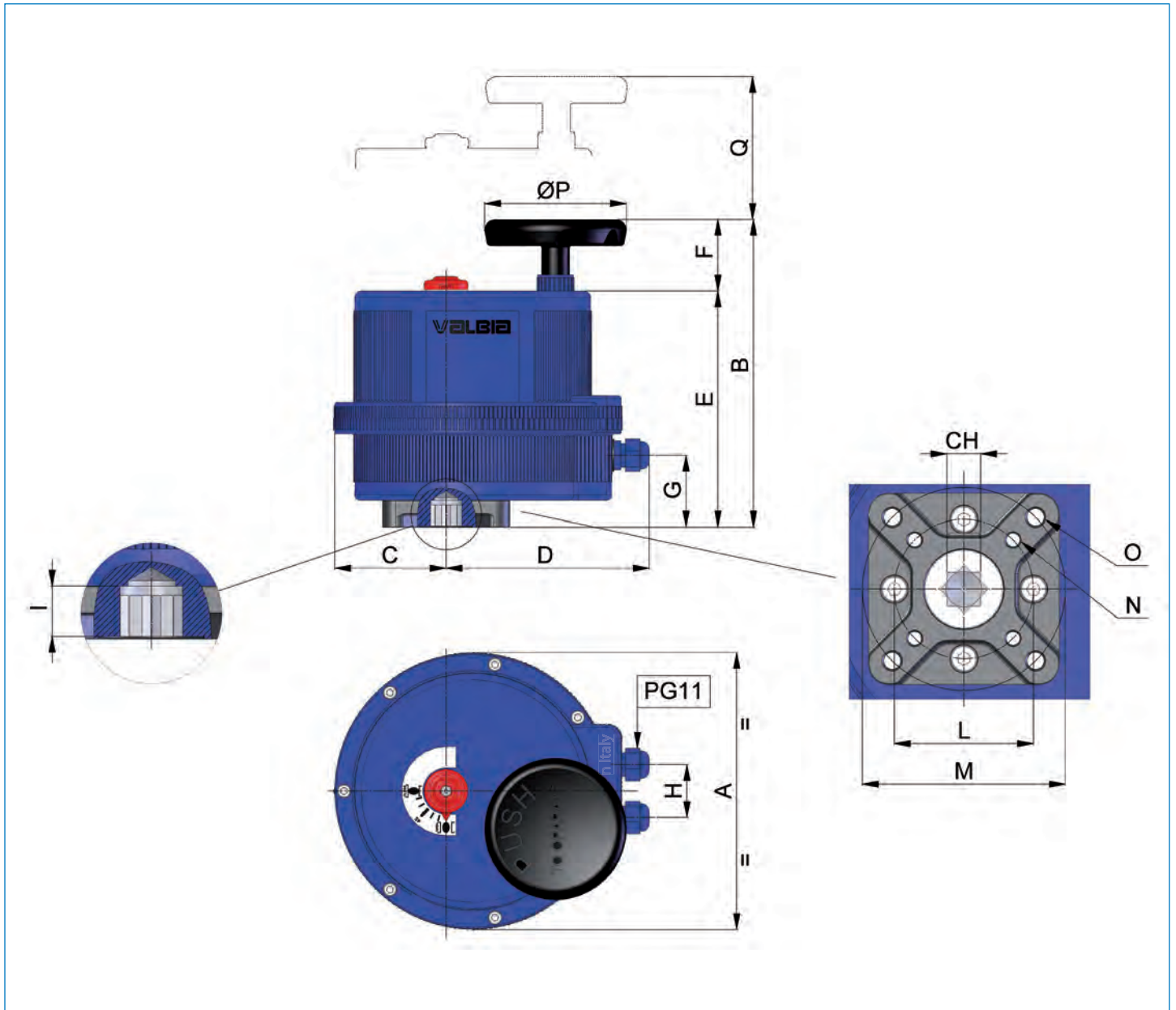

## MOD. VB015 – VB350







MOD.	FORATURA DRILLING ISO 5211	CH	A	B	C	D	E	F	G	H	I	L	M	N	O	ØP	Q
VB015	F03-F05*	11	123	141,5	42,5	120,5	126	15,5	103	32	14	36	50	M5X12	M6X14	68	65
VB030	F03-F05*	11	157	188	60,5	129,5	146	42	33	36	12	36	50	M5X12	M6X14	65	100
VB060	F05-F07	14	185	215	67,5	146,5	173	42	51	36	16	50	70	M6X15	M8X17	65	110
VB110	F07-F10	17	211	232,1	84	153	178	54,1	54	40	19	70	102	M8X20	M10X20	110	115
VB190	F07-F10	17	211	232,1	84	153	178	54,1	54	40	19	70	102	M8x20	M10x20	110	115
VB270	F07-F10	22	222	233,5	77	170	182	51,5	54	40	24	70	102	M8x20	M10x20	110	115
VB350	F07-F10	22	222	233,5	77	170	182	51,5	54	40	24	70	102	M8x20	M10x20	110	115

\* A richiesta F04 o F07 - Upon request F04 or F07





 CUSTODIA IN LEGA DI ALLUMINIO RIVESTITA DI POLIESTERE  
 ALUMINIUM ALLOY ENCLOSURE WITH POLYESTER POWDER COATING

 SCHEDA DI CONTROLLO  
 CONTROL BOARD

 SCHEDA DI ALIMENTAZIONE  
 POWER SUPPLY BOARD



 **CAMME DI POSIZIONE:**  
 • Camme nere: regolazione delle posizioni di finecorsa di apertura e chiusura.  
 • Camme blu: regolazione delle posizioni apertura e chiusura dei contatti puliti di finecorsa.

 **POSITION CAMS:**  
 • Black cams: limit switches open and close adjustment.  
 • Blue cams: free limit switches open and close adjustment.

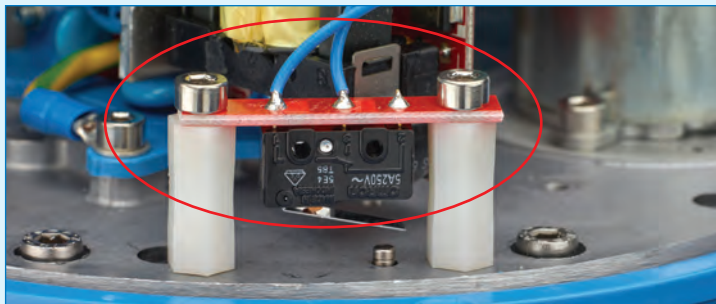

 **INTERRUTTORE ELETTROMECCANICO** (solo per mod. VB110M ÷ VB350M):  
 • Impedisce la rotazione automatica del motore quando l'attuatore è in modalità manuale.

 **SNAP SWITCH** (only for mod. VB110M ÷ VB350M):  
 • To avoid the motor automatic rotation when the actuator is in manual mode.



 **SELETTORE "AUTO-MAN"** (solo per mod. VB110M ÷ VB350M):  
 • Consente la manovra in manuale o automatico.

 **MANUAL OVERRIDE** (only for mod. VB110M ÷ VB350M):  
 • Allow the manual or automatic operation.

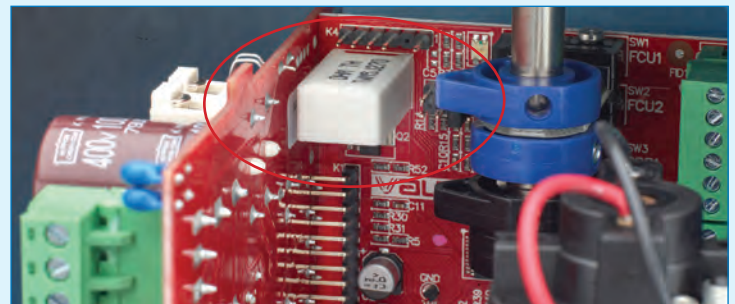





 **RESISTENZA ANTICONDENZA:**  
 • Gestita dalla scheda di controllo per garantire una corretta temperatura interna.



 **HEATING RESISTOR:**  
 • Managed by control board to guarantee the right internal temperature.







 INDICATORE DI POSIZIONE  
 DOME POSITION INDICATOR

 MOTORE DC  
 DC MOTOR

 FERMI MECCANICI  
 MECHANICAL END STOPS

 VOLANTINO MANOVRA MANUALE  
 MANUAL HANDWHEEL



 **VITI DI CHIUSURA CUSTODIE:**  
 • Viti speciali per evitare la perdita durante la manutenzione o l'installazione.  
 • Tutta la viteria esterna è in acciaio inox.

 **CAPTIVE COVER BOLT:**  
 • Cover bolts are specially designed to prevent losing them during maintenance or installation.  
 • All external bolts are stainless steel.



 **APERTURA CUSTODIA SUPERIORE FACILITATA**

 **EASIER UPPER COVER OPENING**

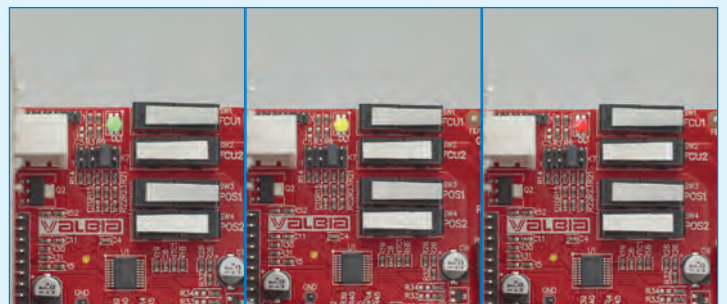

 **LED luminosi per indicare:** alimentazione inserita (verde), stato funzionamento attuatore (giallo) e anomalia (rosso).

 **LED lights to indicate:** power supply ON (green), actuator working conditions (yellow) and fault (red).

MODELLO - MODEL		VB030M	VB060M	VB110M	VB190M	VB270M	VB350M
MASSIMA COPPIA DI LAVORO (Nm) MAX WORKING TORQUE (Nm)		30	60	110	190	270	350
TENSIONE NOMINALE (V) NOMINAL VOLTAGE (V)	BASSA TENSIONE - LOW VOLTAGE	12V AC/DC	12V AC/DC	12V AC/DC	12V AC/DC	12V AC/DC	12V AC/DC
		24V AC/DC	24V AC/DC	24V AC/DC	24V AC/DC	24V AC/DC	24V AC/DC
	MULTITENSIONE - MULTIVOLTAGE	100-240V AC	100-240V AC	100-240V AC	100-240V AC	100-240V AC	100-240V AC
TEMPO DI MANOVRA (sec) - WORKING TIME (sec)		8	9	27	27	50	50
LIMITATORE DI COPPIA - TORQUE LIMITER		STD	STD	STD	STD	STD	STD
DUTY RATING	12V AC/DC	50%	50%	50%	50%	50%	50%
	24V AC/DC	75%	75%	75%	75%	75%	75%
	100-240V AC						
PROTEZIONE - PROTECTION (IP rating/UL)		IP68/Type4x	IP68/Type4x	IP68/Type4x	IP68/Type4x	IP68/Type4x	IP68/Type4x
CUSTODIA - ENCLOSURE		Aluminium	Aluminium	Aluminium	Aluminium	Aluminium	Aluminium
ROTAZIONE - ROTATION		90°	90°	90°	90°	90°	90°
FERMI MECCANICI (solo reg.0-90°) END MECHANICAL STOPS (only reg.0-90°)		NO	NO	STD	STD	STD	STD
COMANDO EMERGENZA MANUALE MANUAL OVERRIDE		STD 10mm	STD 10mm	STD con volantino with hand wheel	STD con volantino with hand wheel	STD con volantino with hand wheel	STD con volantino with hand wheel
INDICATORE DI POSIZIONE TRIDIMENSIONALE DOME POSITION INDICATOR		☑ STD	☑ STD	STD	STD	STD	STD
TEMPERATURA DI UTILIZZO - WORKING TEMPERATURE		-20°C + 55°C	-20°C + 55°C	-20°C + 55°C	-20°C + 55°C	-20°C + 55°C	-20°C + 55°C
RESISTENZA ANTICONDENSA - HEATER		STD	STD	STD	STD	STD	STD
FINECORSO AGGIUNTIVI - ADDITIONAL FREE LIMIT SWITCHES		n°2 STD (type SPDT)	n°2 STD (type SPDT)	n°2 STD (type SPDT)	n°2 STD (type SPDT)	n°2 STD (type SPDT)	n°2 STD (type SPDT)
FORATURA ISO 5211 - DRILLING ISO 5211		F03-F05-F07	F05 - F07	F07 - F10	F07 - F10	F07 - F10	F07 - F10
QUADRO (mm) - SQUARE (mm)		11	14	17	17	22	22
QUADRO A RICHIESTA (mm) - OPTIONAL SQUARE (mm)		9-14	11-17	14-22	14-22	17	17
ALIMENT. MANOVRA DI SICUREZZA FAIL-SAFE OPERATION (BATTERY BACKUP)		A RICHIESTA UPON REQUEST	A RICHIESTA UPON REQUEST	A RICHIESTA UPON REQUEST	A RICHIESTA UPON REQUEST	A RICHIESTA UPON REQUEST	A RICHIESTA UPON REQUEST
NON DISPONIBILE PER MOD. 12V - NOT AVAILABLE FOR MOD. 12V							
POSIZIONATORE STD (4~20mA or 0~10 VDC) REVERSE (20~4mA or 10~0 VDC) STD (4~20mA or 0~10 VDC) REVERSE (20~4mA or 10~0 VDC) MODE POSITIONER		A RICHIESTA UPON REQUEST	A RICHIESTA UPON REQUEST	A RICHIESTA UPON REQUEST	A RICHIESTA UPON REQUEST	A RICHIESTA UPON REQUEST	A RICHIESTA UPON REQUEST
POTENZIOMETRO ROTATIVO (5K Ω 1W) (@ 70°C) ROTARY POTENTIOMETER (5K Ω 1W) (@ 70°C)		A RICHIESTA UPON REQUEST	A RICHIESTA UPON REQUEST	A RICHIESTA UPON REQUEST	A RICHIESTA UPON REQUEST	A RICHIESTA UPON REQUEST	A RICHIESTA UPON REQUEST
POSIZIONE INTERMEDIA MIDDLE POSITION		A RICHIESTA UPON REQUEST	A RICHIESTA UPON REQUEST	A RICHIESTA UPON REQUEST	A RICHIESTA UPON REQUEST	A RICHIESTA UPON REQUEST	A RICHIESTA UPON REQUEST
INGRESSI PER CONNESSIONI ELETTRICHE ELECTRIC CABLE ENTRIES		N°2 M20X1,5	N°2 M20X1,5	N°2 M20X1,5	N°2 M20X1,5	N°2 M20X1,5	N°2 M20X1,5
PESO (Kg) - WEIGHT (Kg)		3,3	4,5	8,5	8,5	9,5	9,5

**DATI DI CONSUMO ATTUATORE ELETTRICO - ELECTRIC ACTUATOR CONSUMPTION DATA**

MODELLO - MODEL		VB030M	VB060M	VB110M	VB190M	VB270M	VB350M
VERSIONE H VERSION H	TENSIONE NOMINALE NOMINAL VOLTAGE	100-240V AC					
	CORRENTE ASSORBITA ABSORBED CURRENT	0,4-0,2 A	0,6-0,3 A	0,4-0,2 A	0,6-0,3 A	0,6-0,3 A	0,75-0,4 A
	POTENZA ASSORBITA ABSORBED POWER	40-48 VA	60-72 VA	40-48 VA	60-72 VA	60-72 VA	75-96 VA
VERSIONE L VERSION L	TENSIONE NOMINALE NOMINAL VOLTAGE	12V 24V AC/DC AC/DC	12V 24V AC/DC AC/DC	12V 24V AC/DC AC/DC	12V 24V AC/DC AC/DC	12V 24V AC/DC AC/DC	12V 24V AC/DC AC/DC
	CORRENTE ASSORBITA ABSORBED CURRENT	2,2-1,8 A 1-0,7 A	3,8-2,85 A 1,8-1,2 A	2,2-1,8 A 1-0,7 A	3,8-2,85 A 1,8-1,2 A	3,8-2,85 A 1,8-1,2 A	4,75-3,65 A 1,95-1,65 A
	POTENZA ASSORBITA ABSORBED POWER	26,5-22 VA 24-17 VA	46-34 VA 43-29 VA	26,5-22 VA 24-17 VA	46-34 VA 43-29 VA	46-34 VA 43-29 VA	57-44 VA 47-40 VA
FREQUENZA FREQUENCY		50/60 HZ					

**MOD. VB030M – VB060M**

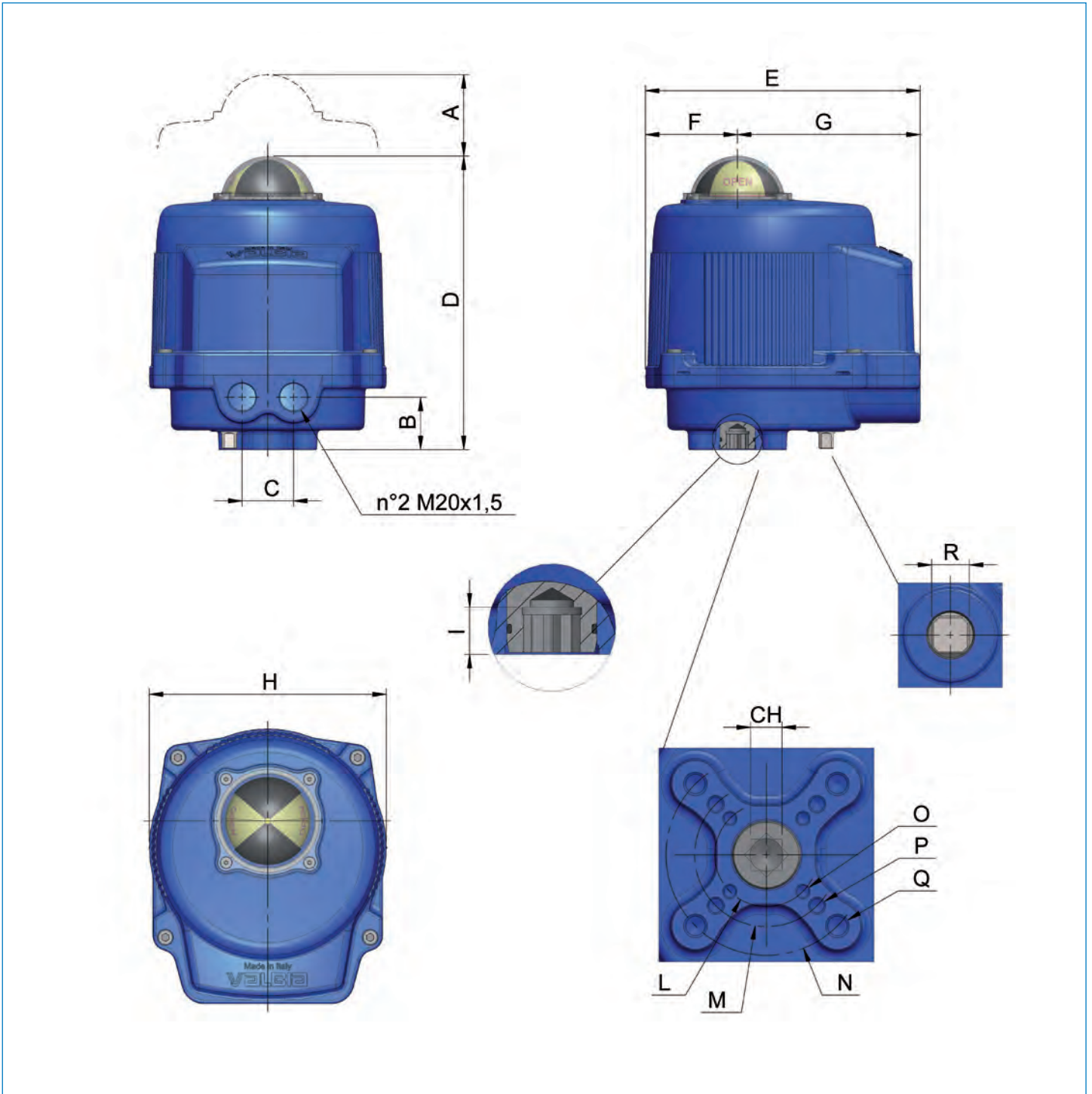

MOD.	FORATURA DRILLING ISO 5211 FLANGE	CH	A	B	C	D	E	F	G	H	I	L	M	N	O	P	Q	R
VB030M	F03-F05-F07	11	139	36	35	199	187	63	124	161	12	36	50	70	M5X8	M6X10	M8X11	10
VB060M	F05-F07	14	139	56	35	220	197	63	134	176	16	-	50	70	-	M6X14	M8X15	10

MOD. VB110M ÷ VB350M

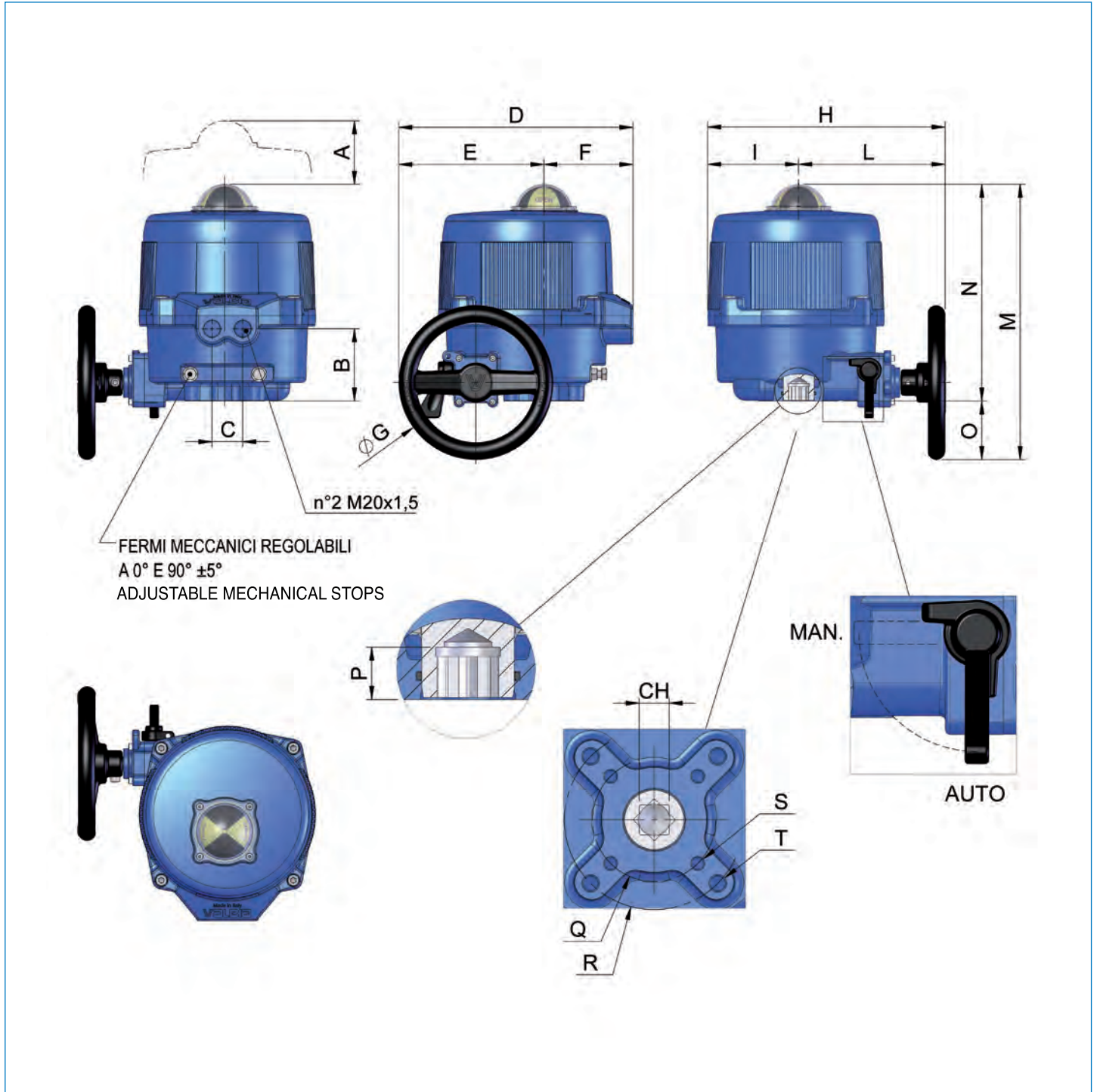

MOD.	FORATURA DRILLING ISO 5211 FLANGE	CH	A	B	C	D	E	F	G	H	I	L	M	N	O	P	Q	R	S	T
VB110M	F07-F10	17	139	82	35	266	165	101	175	270	103	167	313	246	67	19	70	102	M8X15	M10X15
VB190M	F07-F10	17	139	82	35	266	165	101	175	270	103	167	313	246	67	19	70	102	M8X15	M10X15
VB270M	F07-F10	22	139	83	35	279	184	95	175	275	109	166	314	247	67	24	70	102	M8X15	M10X15
VB350M	F07-F10	22	139	83	35	279	184	95	175	275	109	166	314	247	67	24	70	102	M8X15	M10X15

**SCHEMA ELETTRICO VB015 100-240V 50/60Hz  
ELECTRIC WIRING VB015 100-240V 50/60Hz**

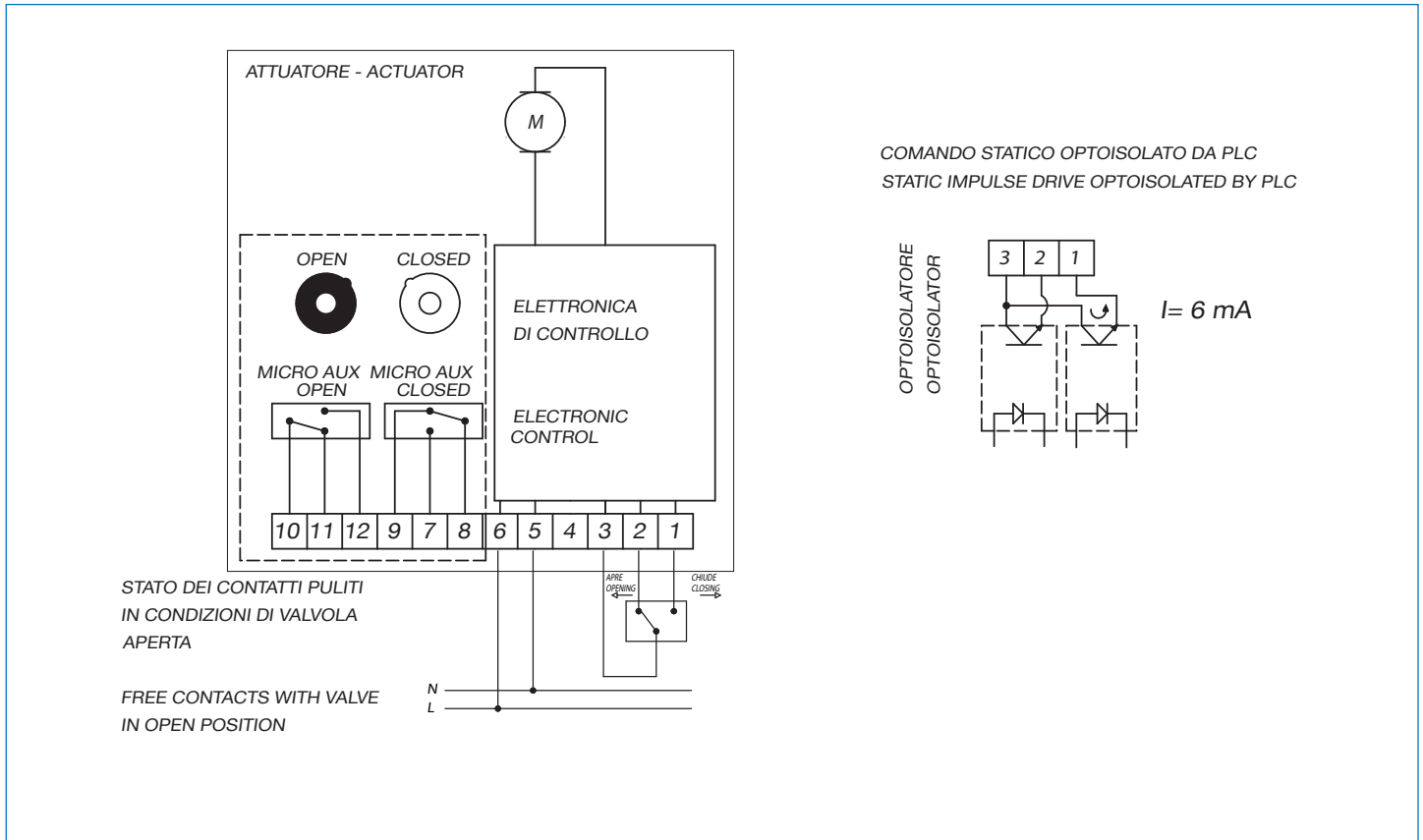

**SCHEMA ELETTRICO VB015 12V-24V AC/DC 50/60 HZ  
ELECTRIC WIRING VB015 12V-24V AC/DC 50/60 HZ**

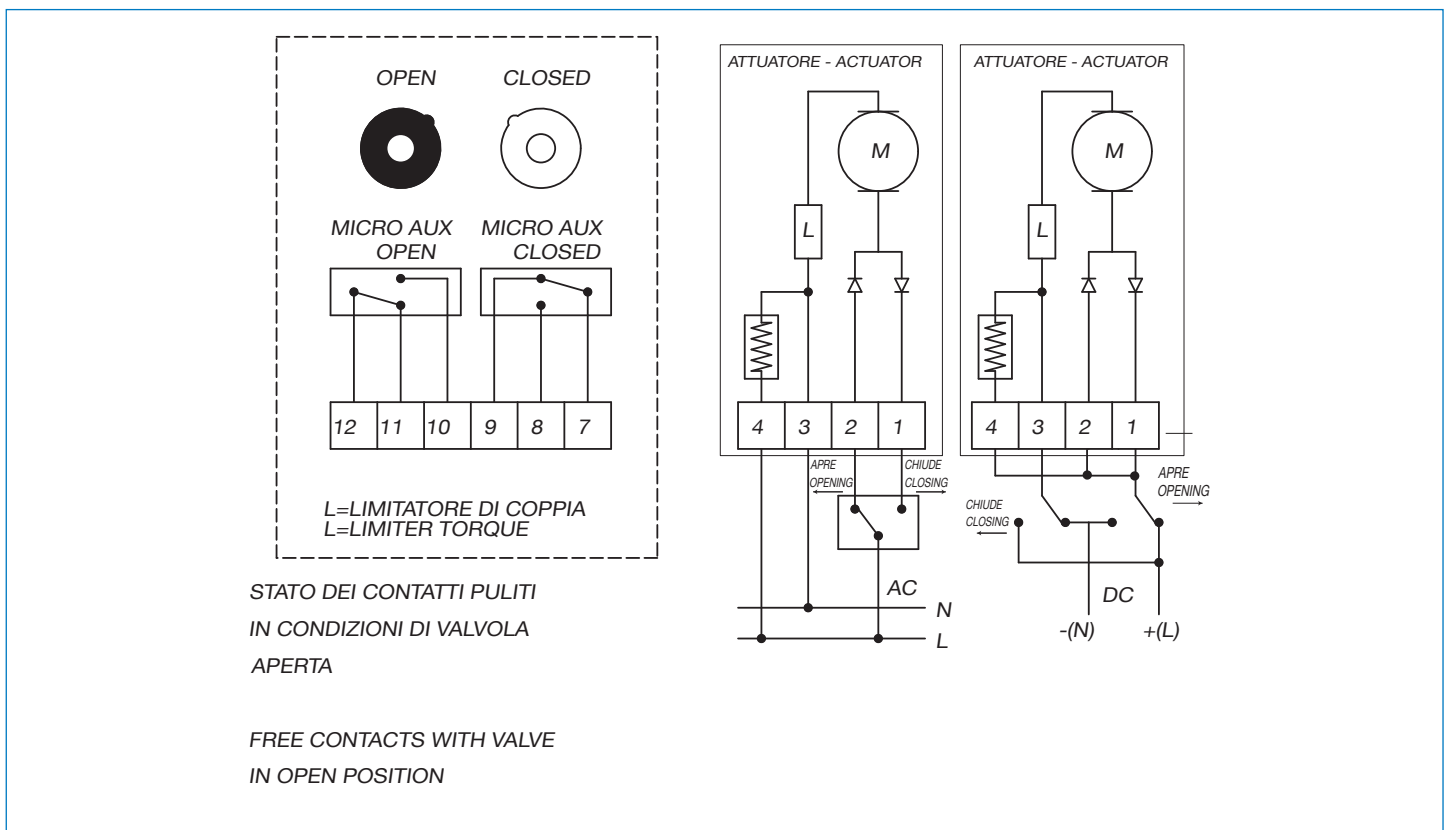

**SCHEMA ELETTRICO DAL VB030 AL VB350 e DAL VB030M AL VB350M 12V AC/DC 50/60 Hz, 24V AC/DC 50/60 Hz, 100-240V AC 50/60 Hz**  
**ELECTRIC WIRING FROM VB030 TO VB350 AND FROM VB030M TO VB350M 12V AC/DC 50/60 Hz, 24V AC/DC 50/60 Hz, 100-240V AC 50/60 Hz**

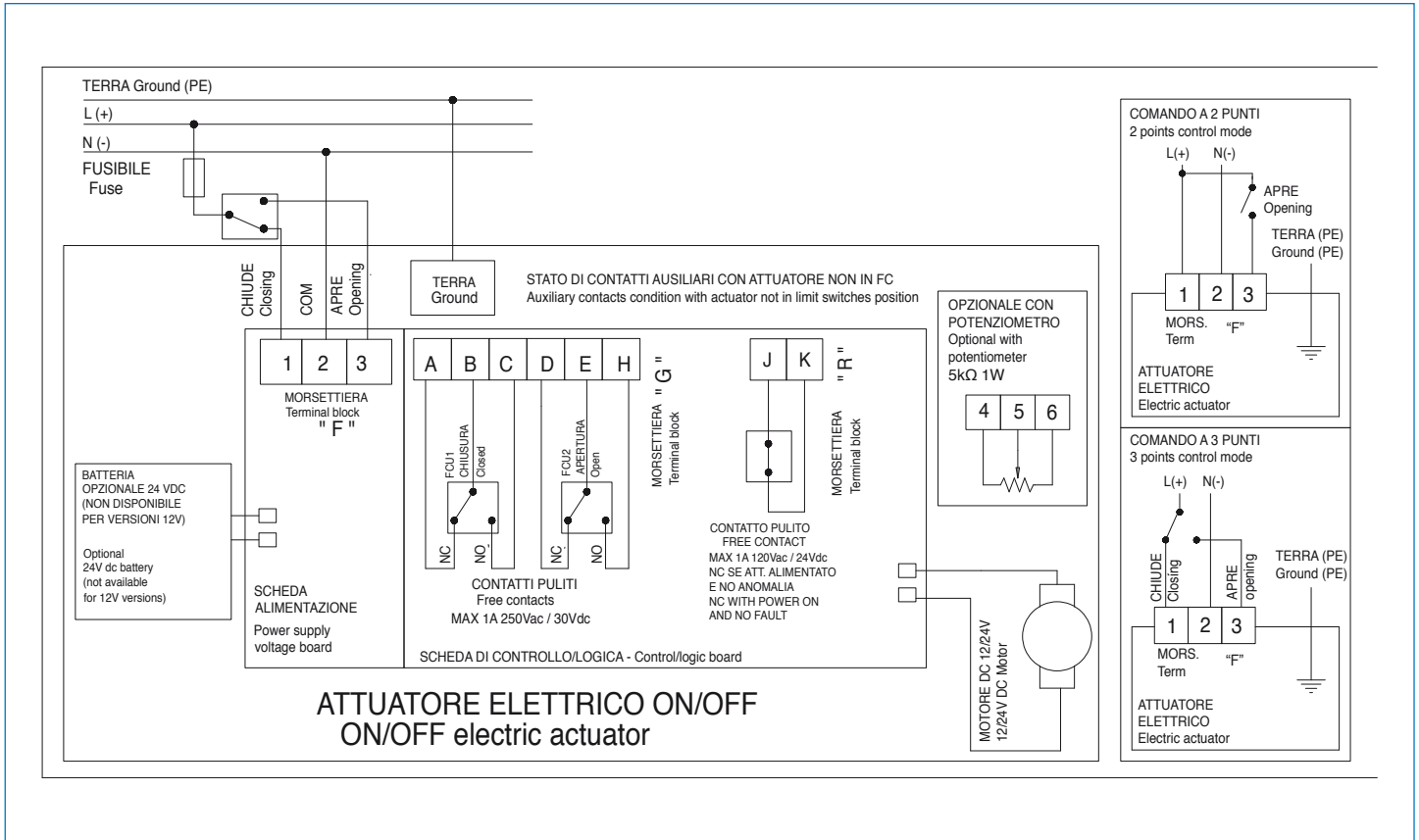

**SCHEMA ELETTRICO CON POSIZIONATORE DAL VB030 AL VB350 e DAL VB030M AL VB350M 12V AC/DC 50/60 Hz, 24V AC/DC 50/60 Hz, 100-240V AC 50/60 Hz**  
**ELECTRIC WIRING WITH POSITIONER FROM VB030 TO VB350 AND FROM VB030M TO VB350M 12V AC/DC 50/60 Hz, 24V AC/DC 50/60 Hz, 100-240V AC 50/60 Hz**

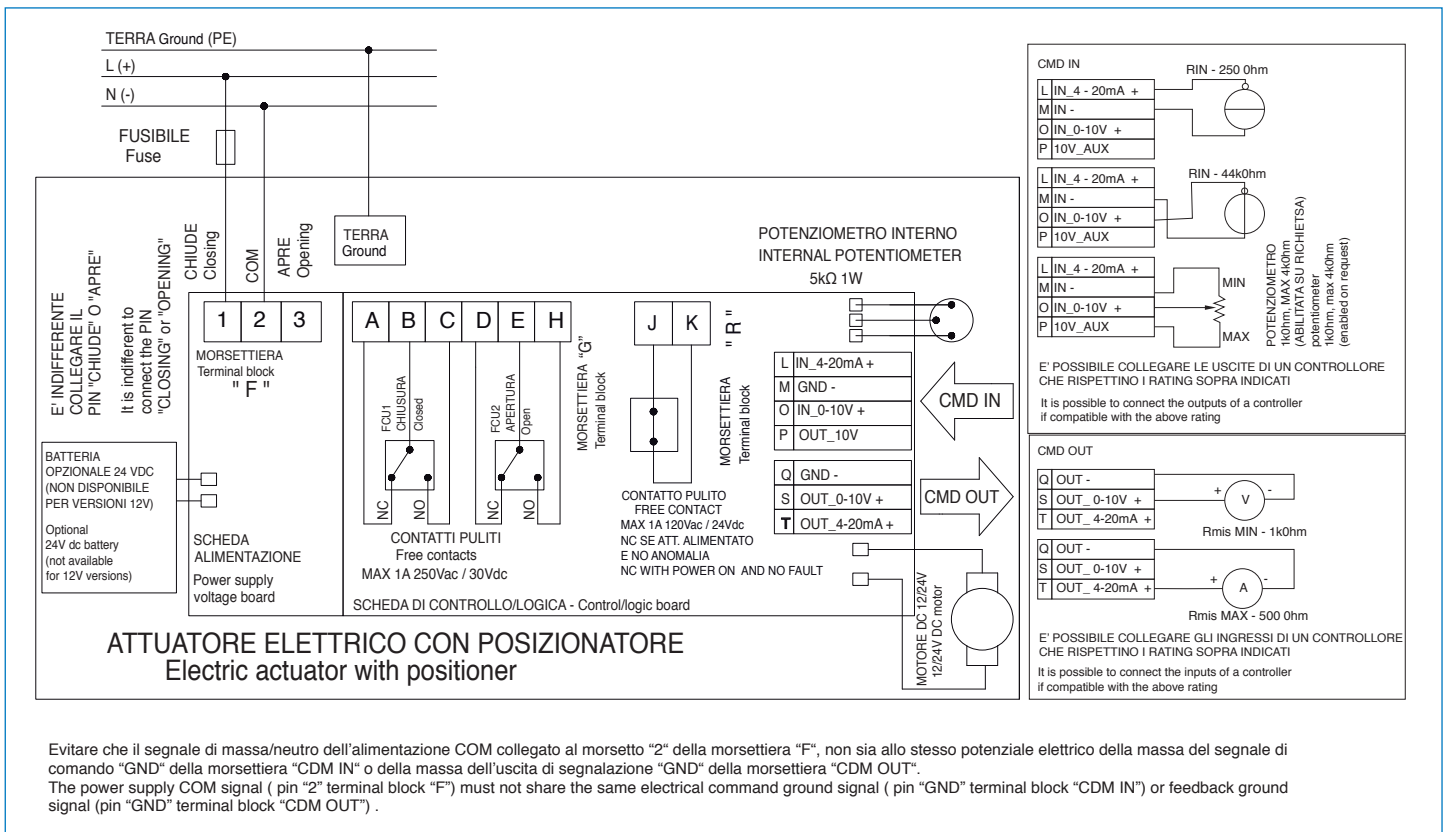

**SCHEMA ELETTRICO CON POSIZIONE INTERMEDIA DAL VB030 AL VB350 E DAL VB030M AL VB350M 24V AC/DC 50/60Hz, 100-240V AC 50/60Hz  
ELECTRIC WIRING WITH MIDDLE POSITION FROM VB030 TO VB350 AND FROM VB030M TO VB350M 24V AC/DC 50/60Hz, 100-240V AC 50/60Hz**

