

TECHNICAL SPECIFICATIONS

Media: water, oil, air, aggressive media, steam^①

Media temperature: -10°C ÷ +180°C

Ambient temperature: -10°C ÷ +60°C

Pilot media^②: instrument air, inert gases

Body material: cast AISI 316L (CF3M), see Piston Actuated Valves Catalogue

Butt weld connection to **DIN 11850-2** pipe or **ISO 65/ANSI B 36.10** pipe

Bonnet material: cast AISI 316L (CF3M), see Piston Actuated Valves Catalogue

Actuator body material: Polyamide PA6 (reinforced fiberglass 30%)

Seal material: PTFE

Position indicator as standard

BENEFITS

Waterhammer-free design for **BPW - BPB** (with flow direction 2 → 1)

Actuator housing rotation 360°

Design suitable for vacuum applications up to 10⁻² mbar

OPTIONS

Stroke regulator assembled ex-factory, see TIS *1801* (e.g. code RPW210STJR0)

Travel switch assembled ex-factory, see TIS *1801* (e.g. code PB208STZ10)

High temperature version, see TIS *6024* (e.g. code BPW207LTY0H)

ACCESSORIES

Position module see TIS *1806*, travel switch kit see TIS *1802*, pilot solenoid valves see TIS *0714*



TYPE: PW / PB



TYPE: RPW / RPB

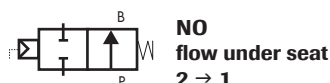

TYPE: BPW / BPB



DIMENSIONS & WEIGHTS		DN15	DN20	DN15	DN20	DN25	DN32	DN40	DN50	DN25	DN32	DN40	DN50
actuator	[mm]	Ø 45		Ø 63						Ø 90			
A	[mm]	65	75	65	75	90	110	120	150	90	110	120	150
B	[mm]	144	149	192	198	212	225	230	248	223	234	239	257
C	[mm]	136	142	184	192	205	217	225	241	216	227	235	250
D	[mm]	123	126	171	176	185	193	198	207	196	202	207	216
E	[mm]	57	57	85	85	85	85	85	85	112	112	112	112
F DIN 11850	[mm]	16	20	16	20	26	32	38	50	26	32	38	50
F ISO 65/ANSI B 36.10	[mm]	17.4	22.8	17.4	22.8	28.3	37.1	42.7	54.8	28.3	37.1	42.7	54.8
G DIN 11850	[mm]	19.2	23.2	19.2	23.2	29.2	36	42	54	29.2	36	42	54
G ISO 65/ANSI B 36.10	[mm]	20.6	26	20.6	26	31.5	41.1	46.7	58.8	31.5	41.1	46.7	58.8
weight	[kg]	0.8	0.9	1.2	1.3	1.5	1.9	2.1	2.9	2.0	2.4	2.6	3.3

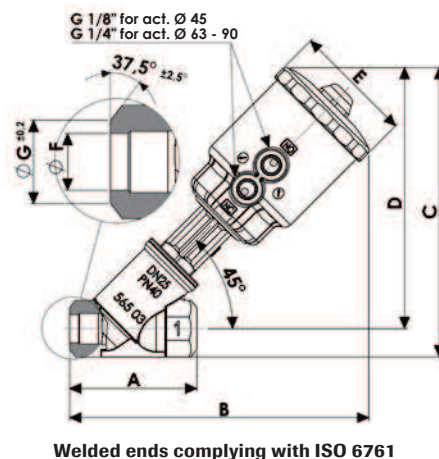

The products listed below comply with the requirements of the European Pressure Equipment Directive 97/23/EC and carry the CE mark when required.

The products fall within the following Pressure Equipment Directive categories:

VALVE TYPE	Bodies	Group 1 gases	Group 1 liquids and Group 2 other fluids
PW - RPW - BPW PB - RPB - BPB	DN15 ÷ DN25 (PN40)	SEP	SEP
	DN32 ÷ DN40 (PN25)	Category I	SEP
	DN50 (PN16)	Category I	SEP

WARNING !

According to the European Pressure Equipment Directive 97/23/EC, liquids whose saturated vapour pressure at the maximum allowable temperature is more than 0,5 barg shall be considered as gases.

NOTES

- ① Steam max. working pressure 10 bar (9 barg)
- ② Please contact M&M sales Department for other pilot media
- ③ Minimum pilot pressure at the max. working pressure: for lower working pressures please refer to the COMPARATIVE CHARTS (for different part numbers: e.g. PW205STW00 please refer to the equivalent part number PG205STW00 for threaded connection)

2/2 WAY PISTON ACTUATED VALVE, BUTT WELD CONNECTION - STAINLESS STEEL

VALVE	body connection	DN	flow rate Kvs	working pressure ①		flow direction	pilot pressure ②		actuator Ø	function
				min.	max.		min.	max.		
code	–	[mm]	[l/min]	[barg]	[barg]	–	[barg]	[barg]	[mm]	–
PW205CTW00	butt weld to DIN 11850-2 pipe	15	75	0	16	1 → 2	3.8	10	45	NC
PW206CTX00		20	133	0	16	1 → 2	5.8	10		
PW205STW00		15	87	0	20	1 → 2	3.7	10	63	
PW206STX00		20	164	0	20	1 → 2	4.4	10		
PW207STY00		25	260	0	20	1 → 2	5	10		
PW208STZ00		32	410	0	16	1 → 2	5.9	10		
PW209STK00		40	700	0	16	1 → 2	9	10		
PW210STJ00		50	950	0	11	1 → 2	8	10		
PW207LTY00		25	260	0	20	1 → 2	2	8	90	
PW208LTZ00		32	410	0	16	1 → 2	3.5	8		
PW209LTK00		40	700	0	16	1 → 2	4	8		
PW210LTJ00		50	950	0	15	1 → 2	6.5	8		
RPW205CTW00	butt weld to DIN 11850-2 pipe	15	75	0	16	2 → 1	4	10	45	NO
RPW206CTX00		20	133	0	16	2 → 1	6.2	10		
RPW205STW00		15	87	0	16	2 → 1	2.5	10	63	
RPW206STX00		20	164	0	16	2 → 1	4.3	10		
RPW207STY00		25	260	0	16	2 → 1	5.5	10		
RPW208STZ00		32	410	0	16	2 → 1	6.5	10		
RPW209STK00		40	700	0	16	2 → 1	9	10		
RPW210STJ00		50	950	0	12	2 → 1	9.4	10		
RPW207LTY00		25	260	0	16	2 → 1	2	8	90	
RPW208LTZ00		32	410	0	16	2 → 1	4	8		
RPW209LTK00		40	700	0	16	2 → 1	5	8		
RPW210LTJ00		50	950	0	16	2 → 1	7	8		
BPW205CTW00	butt weld to DIN 11850-2 pipe	15	75	0	16 / 16	1 → 2 / 2 → 1	6.2 / 5	10	45	NC bidirectional
BPW206CTX00		20	133	0	16 / 7	1 → 2 / 2 → 1	8.7 / 5	10		
BPW205STW00		15	87	0	16	1 → 2 / 2 → 1	5.5 / 3.8	10	63	
BPW206STX00		20	164	0	16	1 → 2 / 2 → 1	6 / 3.8	10		
BPW207STY00		25	260	0	16 / 11	1 → 2 / 2 → 1	6.5 / 3.8	10		
BPW208STZ00		32	410	0	16 / 6	1 → 2 / 2 → 1	6.8 / 3.8	10		
BPW209STK00		40	700	0	12 / 4	1 → 2 / 2 → 1	9 / 3.8	10		
BPW210STJ00		50	950	0	8 / 2.5	1 → 2 / 2 → 1	9 / 3.8	10		
BPW207LTY00		25	260	0	16 / 14	1 → 2 / 2 → 1	4 / 3.3	8	90	
BPW208LTZ00		32	410	0	16 / 12	1 → 2 / 2 → 1	5 / 3.3	8		
BPW209LTK00		40	700	0	16 / 8	1 → 2 / 2 → 1	6 / 3.3	8		
BPW210LTJ00		50	950	0	14 / 6	1 → 2 / 2 → 1	8 / 3.3	8		
PB205CTW00	butt weld to ISO 65/ ANSI B 36.10 pipe	15	75	0	16	1 → 2	3.8	10	45	NC
PB206CTX00		20	133	0	16	1 → 2	5.8	10		
PB205STW00		15	87	0	20	1 → 2	3.7	10	63	
PB206STX00		20	164	0	20	1 → 2	4.4	10		
PB207STY00		25	260	0	20	1 → 2	5	10		
PB208STZ00		32	410	0	16	1 → 2	5.9	10		
PB209STK00		40	700	0	16	1 → 2	9	10		
PB210STJ00		50	950	0	11	1 → 2	8	10		
PB207LTY00		25	260	0	20	1 → 2	2	8	90	
PB208LTZ00		32	410	0	16	1 → 2	3.5	8		
PB209LTK00		40	700	0	16	1 → 2	4	8		
PB210LTJ00		50	950	0	15	1 → 2	6.5	8		
RPB205CTW00	butt weld to ISO 65/ ANSI B 36.10 pipe	15	75	0	16	2 → 1	4	10	45	NO
RPB206CTX00		20	133	0	16	2 → 1	6.2	10		
RPB205STW00		15	87	0	16	2 → 1	2.5	10	63	
RPB206STX00		20	164	0	16	2 → 1	4.3	10		
RPB207STY00		25	260	0	16	2 → 1	5.5	10		
RPB208STZ00		32	410	0	16	2 → 1	6.5	10		
RPB209STK00		40	700	0	16	2 → 1	9	10		
RPB210STJ00		50	950	0	12	2 → 1	9.4	10		
RPB207LTY00		25	260	0	16	2 → 1	2	8	90	
RPB208LTZ00		32	410	0	16	2 → 1	4	8		
RPB209LTK00		40	700	0	16	2 → 1	5	8		
RPB210LTJ00		50	950	0	16	2 → 1	7	8		
BPB205CTW00	butt weld to ISO 65/ ANSI B 36.10 pipe	15	75	0	16 / 16	1 → 2 / 2 → 1	6.2 / 5	10	45	NC bidirectional
BPB206CTX00		20	133	0	16 / 7	1 → 2 / 2 → 1	8.7 / 5	10		
BPB205STW00		15	87	0	16	1 → 2 / 2 → 1	5.5 / 3.8	10	63	
BPB206STX00		20	164	0	16	1 → 2 / 2 → 1	6 / 3.8	10		
BPB207STY00		25	260	0	16 / 11	1 → 2 / 2 → 1	6.5 / 3.8	10		
BPB208STZ00		32	410	0	16 / 6	1 → 2 / 2 → 1	6.8 / 3.8	10		
BPB209STK00		40	700	0	12 / 4	1 → 2 / 2 → 1	9 / 3.8	10		
BPB210STJ00		50	950	0	8 / 2.5	1 → 2 / 2 → 1	9 / 3.8	10		
BPB207LTY00		25	260	0	16 / 14	1 → 2 / 2 → 1	4 / 3.3	8	90	
BPB208LTZ00		32	410	0	16 / 12	1 → 2 / 2 → 1	5 / 3.3	8		
BPB209LTK00		40	700	0	16 / 8	1 → 2 / 2 → 1	6 / 3.3	8		
BPB210LTJ00		50	950	0	14 / 6	1 → 2 / 2 → 1	8 / 3.3	8		