

Standard executions			
Version	Symbol	Type	Item
1/4		090231	AVP14E
3/8		090232	AVP38E
1/2		090233	AVP12E

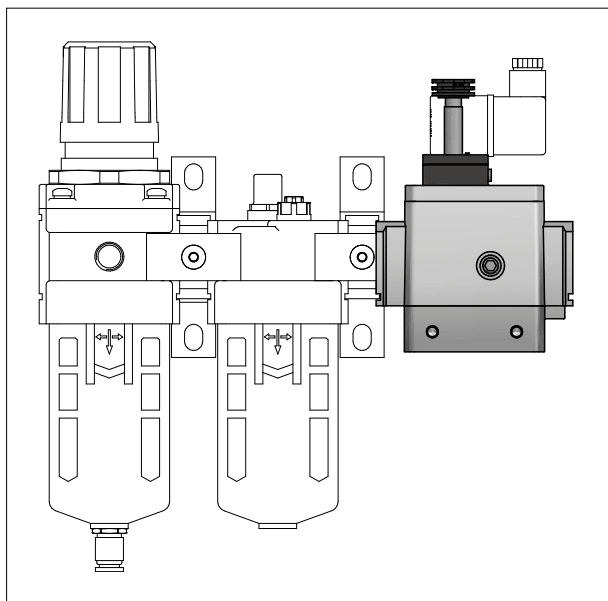

*New*



Soft/start valve, for progressive pressurizing the pneumatic lines when switch on.

Is indicated as safety valve, to quickly exhaust the downstream circuit.

- Manual override;
- Exhausting function;
- Low consumption;
- Modular assembly with airline equipment.

For airline equipment see page 3.2.1

For coils type ASA12... see page 2.200.1

For connector type A122... see page 2.210.20

Pressure gauges to be ordered separately, see page 3.50.1

For accessories, assembly kits and spare parts see page 3.5.1

Technical data				
Fluid		Compressed air		
Maximum pressure		15 bar		
Regulation range		0,2 ÷ 10 bar		
Temperature range		0 ÷ 60 °C		
Size		1/4"	3/8"	1/2"
Section	1 (P) → 2(A)	20 mm <sup>2</sup>	37 mm <sup>2</sup>	61 mm <sup>2</sup>
	2 (P) → 3(A)	24 mm <sup>2</sup>	49 mm <sup>2</sup>	76 mm <sup>2</sup>
Gauges mountings		1/8"	1/8"	1/8"
Manual Override		Monostable		
Materials	Body and cup protection:	Painted aluminium		
	Cover	Painted aluminium		
	End cover	Painted aluminium		
	Piston guide	POM / NBR		
	Seals	NBR		
	Internal parts	Brass / NBR		
	Springs	Steel		

### Working principles

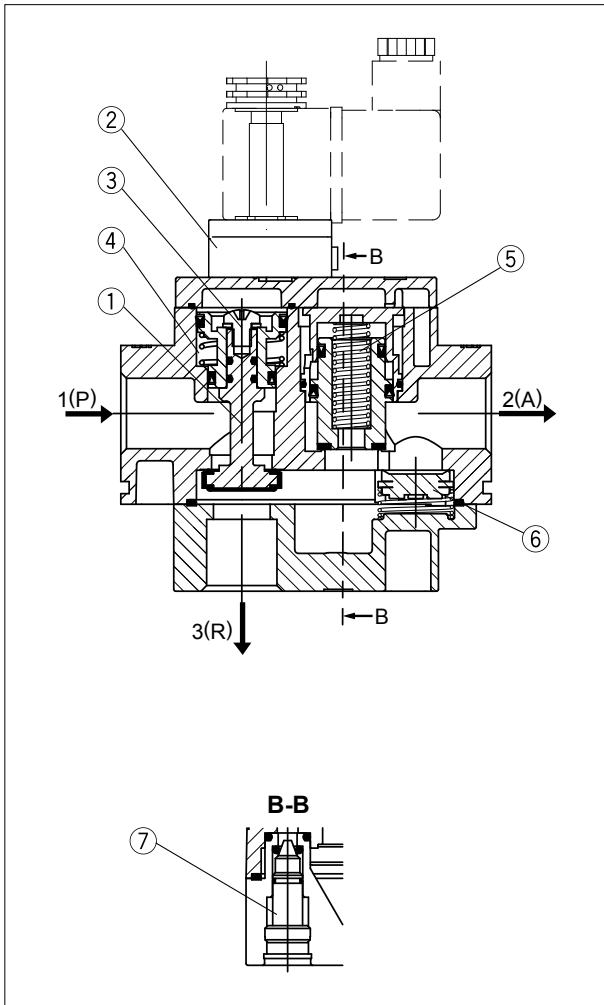

Pressure in the start-up phase of the valve

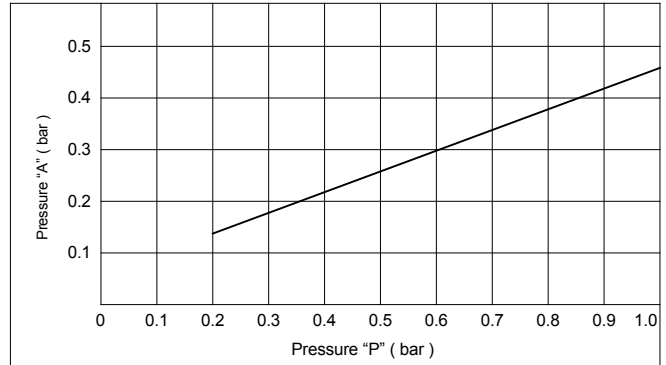

Flow rates related to the number of turns of the needle – P = 5 bar (P: 5 bar)

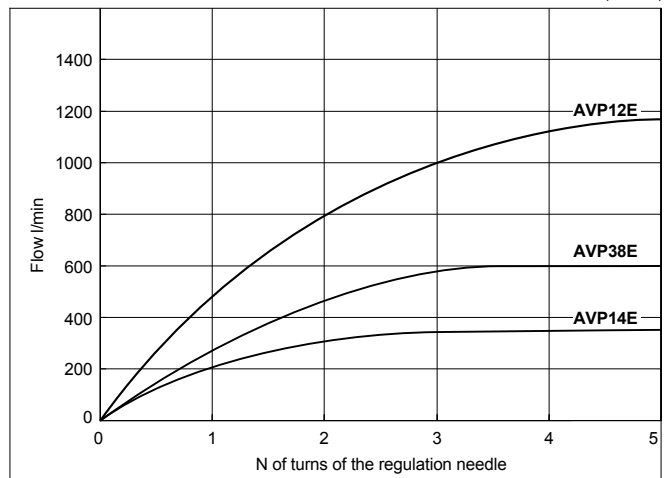

### OPERATING CONDITIONS

#### Start-up phase

By actuating electro-pilot ② ( or the manual override ), piloting air will push the poppet ① down opening this way the main power valve and at the same time, closing the exhaust ⑥.  
Air from inlet ① will go through the regulation needle ⑦ and out to ④.

#### Switching and working phase

In the moment the pressure difference between ① and ④ is  $P(A) \geq \frac{1}{2} P(P)$  the poppet ⑤ fully open and outlet pressure ④ rapidly increase until equalize inlet one at ①.  
Soft-start valve will not represent any obstacle for the air-flow going through it.

#### Closing and exhausting phase

By deactivating electro-pilot ② ( or the manual override ), the poppet ① will reposition stopping the air from inlet ① and contemporary exhaust the downstream air in the circuit from ⑥.

