

VACUUM PUMPS VTL 40/G1 - 105/G1

These vacuum pumps have a suction flow rate of 40, 50, 65, 75, 90 and 105 m³/h.

The vacuum lubrication with oil recirculation is adjusted via two oilers located in correspondence of the support bearings.

The rotor is cantilevered-fitted on the motor shaft and supported by independent bearings housed in the two pump flanges.

The pump and the electric motor are, therefore, two independent units and fixed onto a special support and connected to each other via an elastic transmission joint.

All this allows using standard electric motors, in the shapes and sizes indicated in the table.

The pump is surface cooled. Heat is dispersed from the outer surface, suitably finned, by means of a radial fan placed between motor and pump.

An oil recovery tank is installed on the pump exhaust. This tank contains a separator filter that prevents oil mists and reduces noise.

A check valve and a filter must be installed on the suction inlet.

These pumps are supplied with three-phase electric motors only.

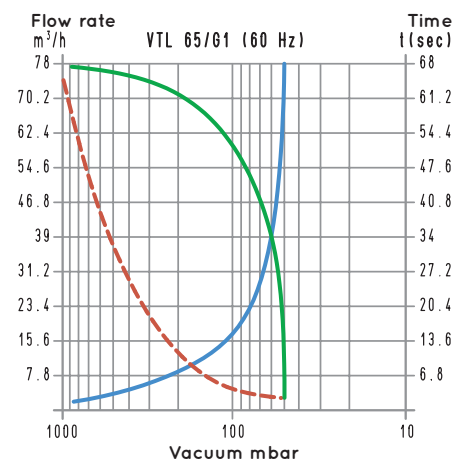
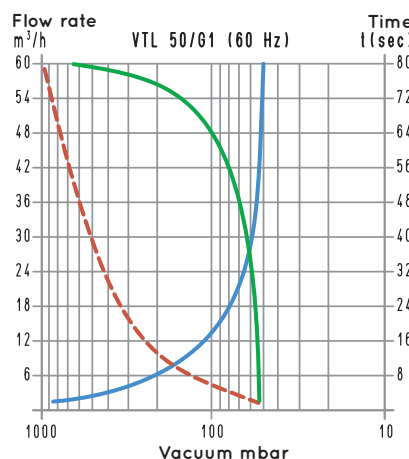
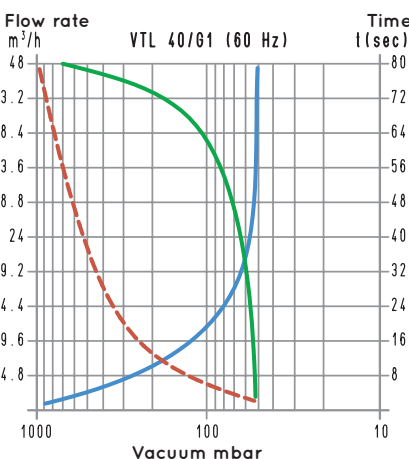
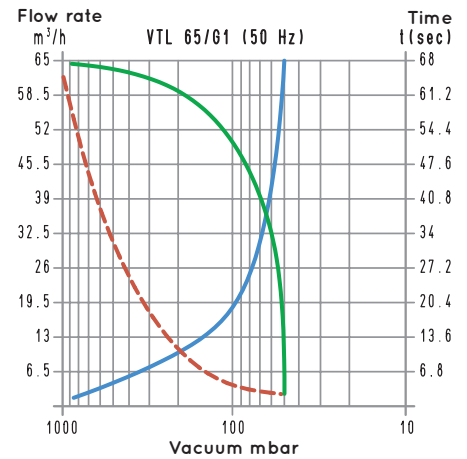
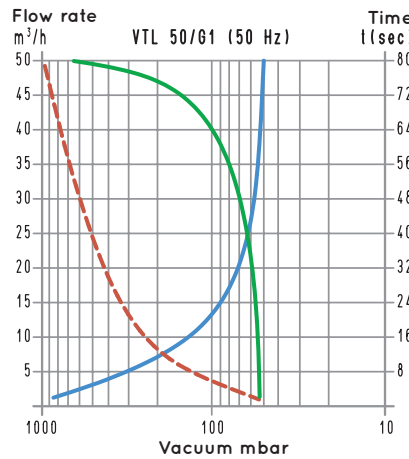
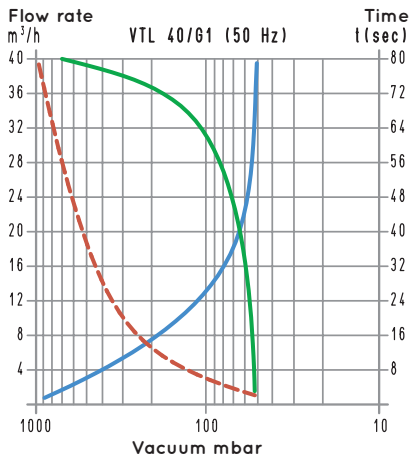
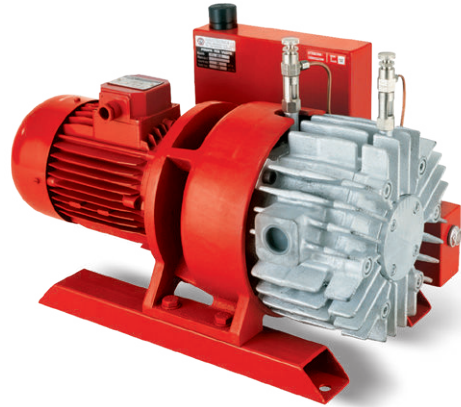

To calculate the emptying time of a volume of V_1 , use the following formula: $t_1 = \frac{t \times V_1}{100}$

- Curve relative to the flow rate (referring to the suction pressure)
- - - Curve relative to the flow rate (referring to a 1013 mbar pressure)
- Curve regarding the emptying time of a 100-litre volume

- V_1 : Volume to be emptied (l)
- t_1 : time to be calculated (sec)
- t : time obtained in the table (sec)

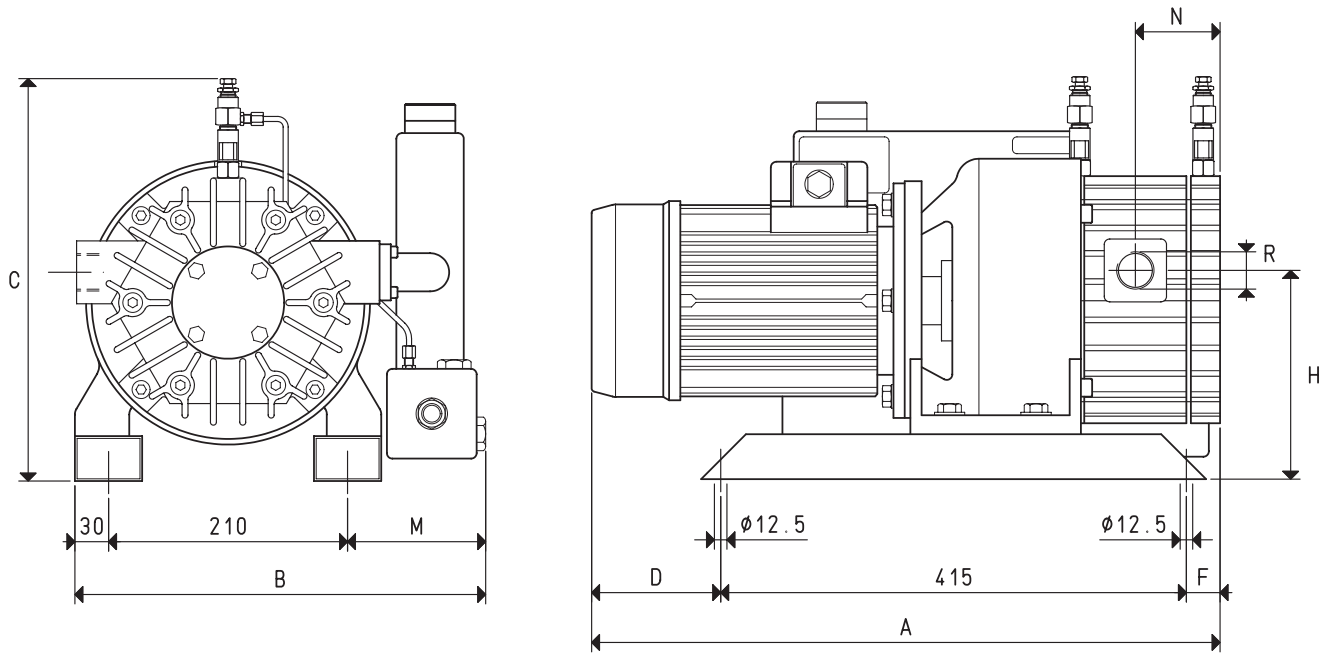

Item		VTL 40/G1		VTL 50/G1		VTL 65/G1	
Frequency		50Hz	60Hz	50Hz	60Hz	50Hz	60Hz
Flow rate	m ³ /h	40.0	48.0	50.0	60.0	65.0	78.0
Final pressure	mbar abs.	50		50		50	
Motor performance 3~	volt	230/400±10%	265/460±10%	230/400±10%	265/460±10%	230/400±10%	265/460±10%
Motor power 3~	Kw	1.10	1.35	1.50	1.80	1.50	1.80
Motor protection	IP	55		55		55	
Rotation speed	g/min ⁻¹	1440	1750	1440	1750	1440	1750
Motor shape		B5		B5		B5	
Motor size		90		90		90	
Noise level	dB(A)	68	70	68	70	70	72
Max weight 3~	kg	51.0		54.0		71.0	
A		520		560		580	
B		365		365		365	
C		350		350		350	
D		60		115		120	
F		45		30		45	
H		186		186		186	
M		125		125		125	
N		70		80		80	
R	Ø gas	G1"		G1"		G1"	
Accessories and Parts		VTL 40/G1		VTL 50/G1		VTL 65/G1	
Oil charge	L	0.85		1.00		1.00	
Lubricating oil	type	ISO 100		ISO 100		ISO 100	
6 vanes	item	00 VTL 40G1 10		00 VTL 50G1 10		00 VTL 65G1 10	
Sealing kit	item	00 KIT VTL 40G1		00 KIT VTL 50G1		00 KIT VTL 65 G1	
Check valve	item	10 05 10		10 05 10		10 05 10	
Suction filter	item	FB 30/FC 30		FB 30/FC 30		FB 30/FC 30	
Adjustable drip oiler	item	00 VTL 00 11		00 VTL 00 11		00 VTL 00 11	