

Specifically designed for very high frequency gripping and release applications, these single-stage vacuum generators are based on the Venturi principle and are equipped with a pneumatic ejector to allow maximum speed in restoring the atmospheric pressure of use. The key features are its considerably reduced weight, supply air pressure of less than 4 bar, low energy consumption, simplicity of installation and low noise level during use, thanks to the high sound dampening silencer installed as standard on the generators. The pneumatic ejector can be deactivated simply by means of a membrane integrated onto the generators. These generators, like the previous ones, are also fully made with anodised aluminium.

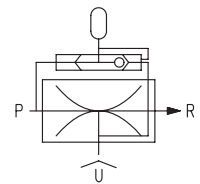
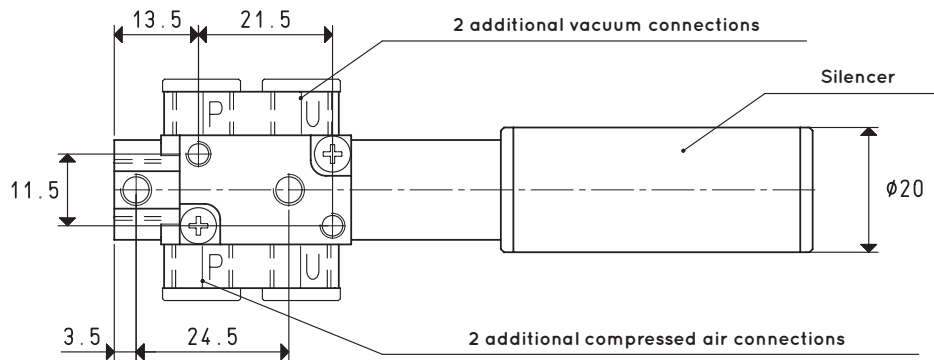
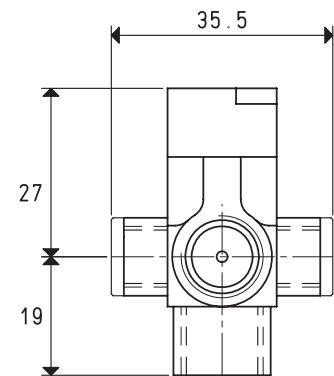
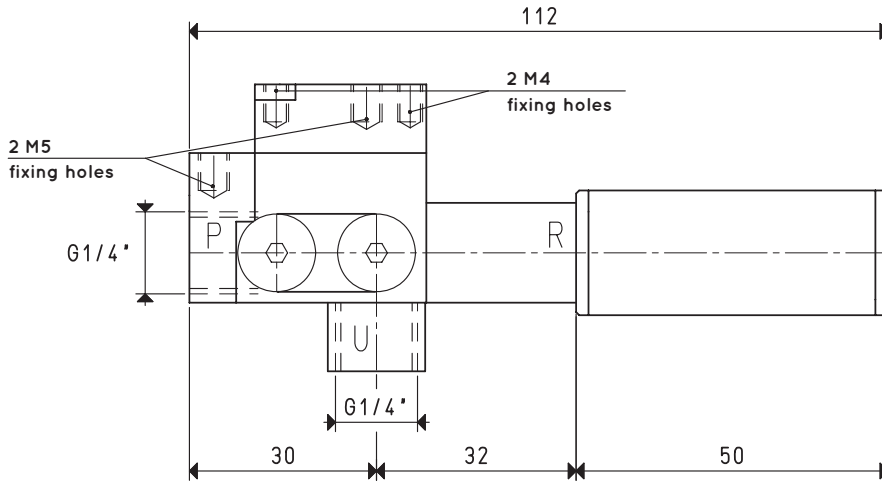

P=COMPRESSED AIR CONNECTION R=EXHAUST U=VACUUM CONNECTION

Item		FVG 3			FVG 5		
Intake air flow rate	m ³ /h	2.6	2.8	3.0	4.8	4.9	5.0
Maximum level of vacuum	-kPa	43	61	85	40	61	85
Final pressure	mbar abs.	570	390	150	600	390	150
Supply pressure	bar	2	3	4	2	3	4
Optimal supply pressure	bar			4			4
Air consumption	NI/s	0.7	0.9	1.2	1.3	1.7	2.2
Operating temperature	°C			-20 / +80			-20 / +80
Noise level at optimal supply pressure	dB(A)			68			74
Weight	g			84			86
Spare parts		FVG 3			FVG 5		
Silencer	item	SSX 1/4"			SSX 1/4"		
Sealing kit and reed valves	item	00 15 502			00 15 502		

Note: All vacuum values indicated in the table are valid at the normal atmospheric pressure of 1013 mbar and obtained with a constant supply pressure.

Vacuum generator supply must be carried out with non-lubricated compressed air, 5 micron filtration, in accordance with standard ISO 8573-1 class 4.

Air flow rate (NI/s) at different level of vacuum (-KPa) at optimal supply pressure

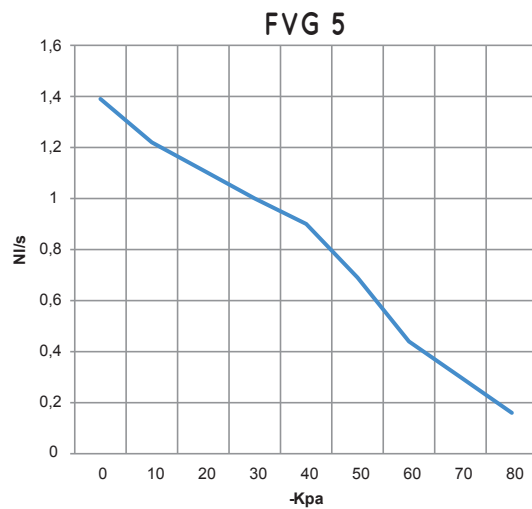
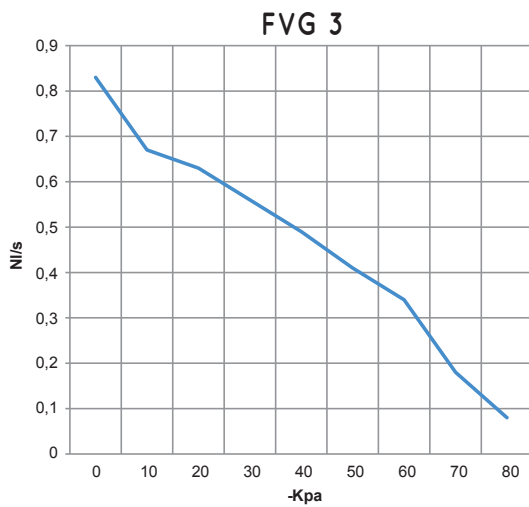

Generator item	Supp. press. bar	Air consumption NI/s	Air flow rate (NI/s) at different levels of vacuums (-KPa) at optimal supply pressure										Max vacuum -KPa
			0	10	20	30	40	50	60	70	80		
FVG 3	4.0	1.2	0.83	0.67	0.63	0.56	0.49	0.41	0.34	0.18	0.08	85	
FVG 5	4.0	2.2	1.39	1.22	1.11	1.00	0.90	0.69	0.44	0.30	0.16	85	

Evacuation rates (ms/l = s/m³) at different levels of vacuums (-KPa) at optimal supply pressure

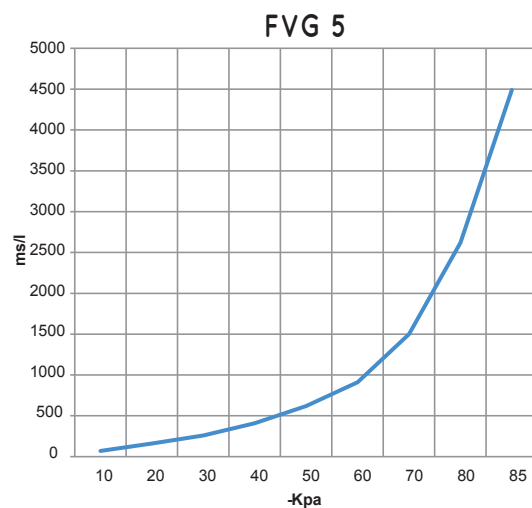
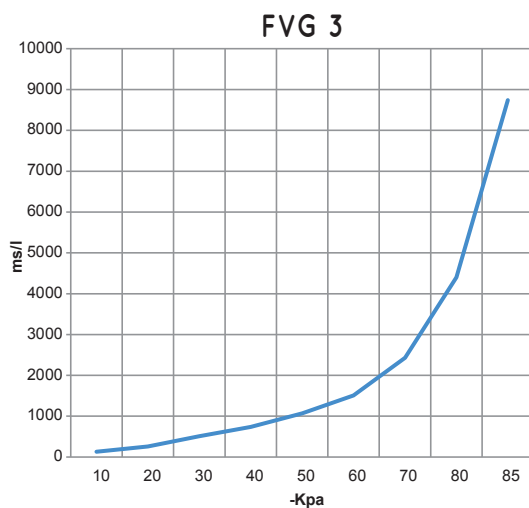

Generator item	Supp. press. bar	Air consumption NI/s	Evacuation rates (ms/l = s/m ³) at different levels of vacuums (-KPa) at optimal supply pressure										Max vacuum -KPa
			10	20	30	40	50	60	70	80	85		
FVG 3	4.0	1.2	130	260	510	740	1070	1510	2430	4400	8740	85	
FVG 5	4.0	2.2	70	160	260	410	620	910	1500	2620	4490	85	