

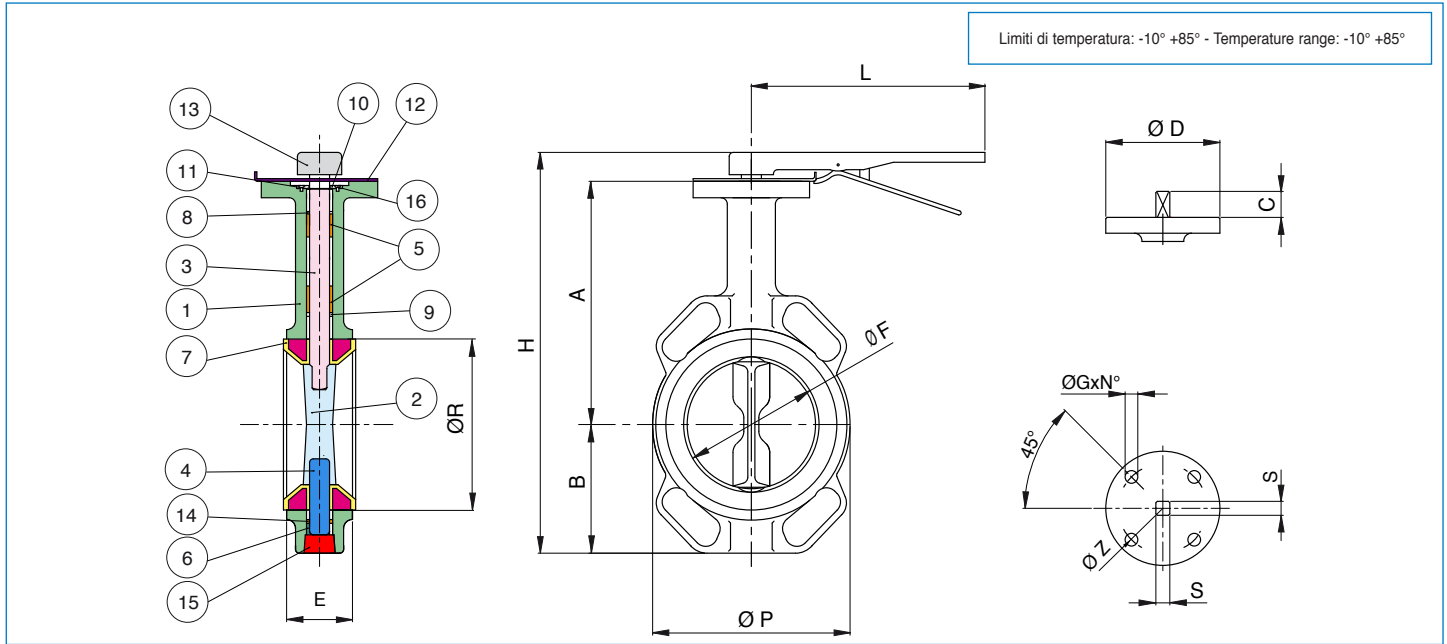

serie **EUROFLY**
 Artt. **600117 – 600119**
 DISC GGG40 DISC INOX

Butterfly valve WAFER type PN16, body in cast iron G250 + Epoxy painting, NBR seat.



Art. 600117

Art. 600119

POS.	DENOMINAZIONE	PART NAME	DESCRIPTION	TEILBENENNUNG	DENOMINACION	MATERIALE - MATERIALS - MATERIAUX - WERKSTOFF - MATERIAL		N°P
1	CORPO	BODY	CORPS	GEHÄUSE	CUERPO	EN-GJL 250	EN-GJL 250	1
2	DISCO	DISC	PAPILLON	KLAPPE	MARIPOSA	EN-GJS 400	A351-CF8M	1
3	ASTA	STEM	AXE	WELLE	EJE	SS416	SS416	1
4	ASTA INFERIORE	STEM	AXE	WELLE	EJE	SS416	SS416	1
5	GUARNIZIONE ASTA	STEM SEAT	JOINT DE L'AXE	SPINDELDICHTUNG	ASIENTO EJE	PTFE	PTFE	1
6	GUARNIZIONE ASTA INF.	STEM SEAT	JOINT DE L'AXE	SPINDELDICHTUNG	ASIENTO EJE	PTFE	PTFE	1
7	GUARNIZIONE	SEAT	MANCHETTE	MANCHETTE	ASIENTO	NBR	NBR	1
8	O-RING	O-RING	O-RING	O-RING	O-RING	NBR	NBR	1
9	O-RING	O-RING	O-RING	O-RING	O-RING	NBR	NBR	1
10	RONDELLA	WASHER	RONDELLE	UNTERLEGSCHIEBE	ARANDELA	CARBON STEEL	CARBON STEEL	1
11	ANELLO ELASTICO	CIRCLIP	ANNEAU RESSORT	ELASTISCHER RING	SEEGER	SPRING STEEL	SPRING STEEL	1
12	PIASTRA DI ARRESTO	RETAINER	PLAQUE D'ARRET	ANSCHLAGPLATTE	ANILLO DE SEGURIDAD	CARBON STEEL	CARBON STEEL	1
13	LEVA	LEVER	LEVIER	HEBEL	PALANCA	EN-GJL 250	EN-GJL 250	1
14	O-RING	O-RING	O-RING	O-RING	O-RING	NBR	NBR	1
15	TAPPO	CAP	CLAPET	SCHUTZKAPPE	TAPA	CARBON STEEL	CARBON STEEL	1
16	VITE	SCREW	VIS	SCHRAUBE	TORNILLO	CARBON STEEL	CARBON STEEL	2

MISURA / DN SIZE / DN	H	A	B	L	ØF	ØP	ØR	E	ØD	C	ØG	N°	ØZ	S	Kv	PN	Kg
32	190	112	58	162	35	85	56	33	90	22	7/10	4	50/70	11	51,0	PN16 - ANSI 150	2,04
40	204	112	70	162	41	95	68	33	90	22	7/10	4	50/70	11	68,0	PN16 - ANSI 150	2,30
50	236,1	142,7	71,4	267	52,25	100	73,3	43	90	22	7/10	4	50/70	11	99,0	PN16 - ANSI 150	3,24
65	255,2	155,4	77,8	267	64,05	120	86	46	90	22	7/10	4	50/70	11	169,0	PN16 - ANSI 150	3,88
80	272,8	161,8	89	267	78,65	127	100,9	46	90	22	7/10	4	50/70	11	260,0	PN16 - ANSI 150	4,18
100	302	178	102	267	104,15	161	132	52	90	22	10	4	70	14	516,0	PN16 - ANSI 150	5,36
125	335,5	190,5	123	267	123,35	190	156	56	90	22	10	4	70	14	879,0	PN16 - ANSI 150	7,10
150	365,2	205,2	138	267	155,85	215	185,4	56	90	22	10	4	70	14	1358,0	PN16 - ANSI 150	8,28
200	439,5	237	168	358	202,55	268	235,2	60	150	34,5	12	4	102	17	2697,0	PN16 - ANSI 150	13,70
250	509,8	268,3	207	358	250,55	325	289,4	68	150	34,5	12	4	102	22	4592,0	PN16 - ANSI 150	21,82
300**	586,5	308,5	243,5	358	301,65	375	341,2	78	150	34,5	14	4	125	27	7095,0	PN16 - ANSI 150	32,09
350*	-	386	259	-	341,7	436	-	78	175	65	18	4	140	Ø 28	10249	16	-
400*	-	400	309	-	397,5	488	-	102	175	75	18	4	140	Ø 38	14094	16	-
450*	-	422	327	-	448,4	536	-	114	175	75	18	4	140	Ø 37,9	18666	16	-
500*	-	480	361	-	499	593	-	127	210	90	23	4	165	Ø 45	24001	16	-
600*	-	562	459	-	600,1	820	-	151	210	100	23	4	165	Ø 55,6	37080	16	-

* Incluso riduttore di manovra manuale - Gear operator included

** Consigliabile con riduttore di manovra art. 89008178 - Advisable to use with gear operator art.89008178