

Complex Configurations  
& Tight Spaces

Ideal for Corrosion  
Resistant Applications

Reduces  
Conveyor Footprint

Capable of Curves,  
Inclines & Declines

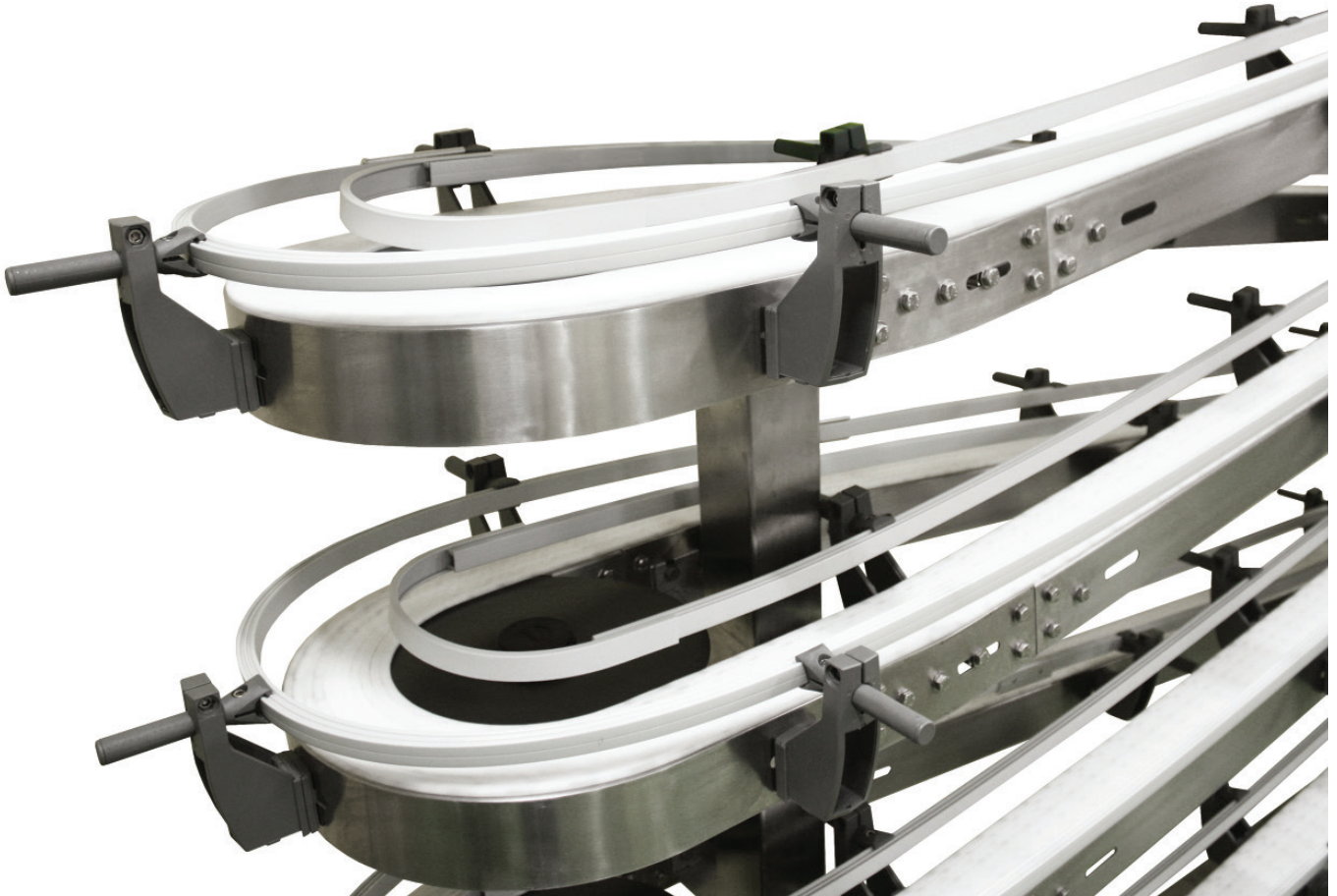

# FlexMove<sup>®</sup> STAINLESS SERIES

High Performance, Stainless Steel,  
Flexible Chain Conveyors



**FlexMove® Stainless Steel Conveyors are best for:**

- Part Handling
- Tight Spaces
- Buffering
- Elevation Changes
- Accumulation
- Long Lengths
- Complex Configurations
- Caustic & Corrosive Environments
- Curves, Jogs, Inclines, Declines

**Sizes & Measurements**

- Widths: 65 mm, 85 mm, 105 mm, 180 mm and 260 mm
- Lengths: up to 30 m (98 ft)

**Loads & Speeds**

- Loads up to 65 kg/m (44 lbs/ft)
- Speeds: up to 58 mpm (190 fpm)

**Plastic Chain Types**

- Standard: Low Friction & Friction Top Inserts
- Specialty
  - Conductive
  - Cleated
  - Hardened Steel Top
  - Roller Top
  - Magnet Top
  - And Many More

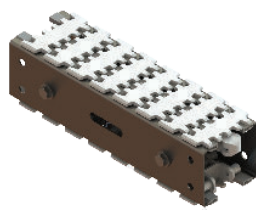

Flat

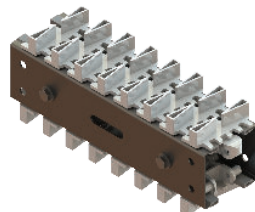

Cleated

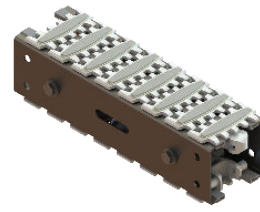

Friction Top

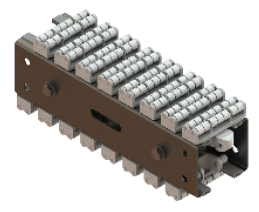

Roller Top

**Modules**

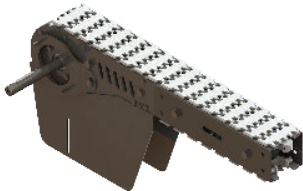

Drive Tail

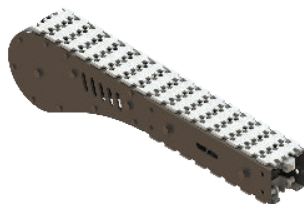

Idler Tail

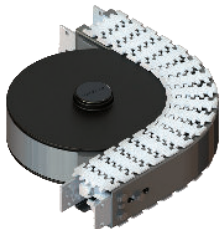

Curves from 15° to 180°



Inclines/Declines from 5° to 90°

**Support Stands**

- Tripod Supports
- Horizontal & Adjustable Angle Supports also available



**Guiding**

- Fully Adjustable
- Adjustable Width/Height
- Twin Rail
- Overhead Guide

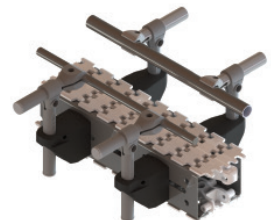

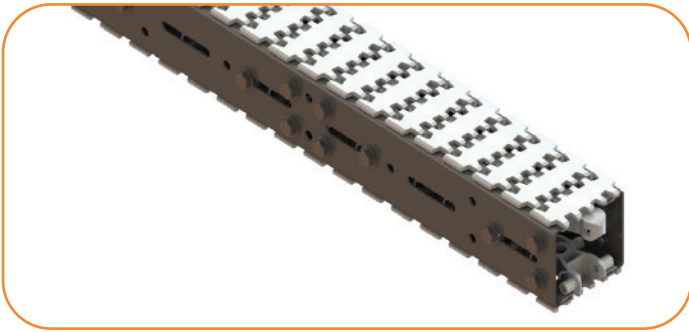

## Complete Stainless Steel Construction

- Stainless Steel Construction is ideal for corrosion resistant applications or packaging lines

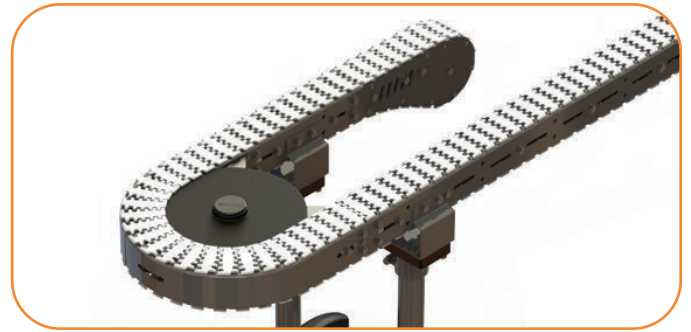

## Wheel Corners

- Standard wheel corners eliminate friction allowing for complicated multi-curved configurations



## Wedge Elevator

- Wedge Elevators save footprint space by vertically lifting or lowering a product using a specialty gripper chain



## Alpines

- Alpine configurations available for product buffering, elevation changes or coding/curing applications

## The Benefits of a Dorner FlexMove Stainless Steel Series Conveyor

### Reduces Costs

- Available pre-assembled to your exact specifications; saving labor costs
- FlexMove Solutions eliminates unnecessary cutting, inventory and waste

### Delivers Fast

- Dorner sets the industry standard for delivery
- FlexMove is shattering the norm with conveyors available to ship in as little as 15 working days

### Flexible

- Provides capability for vertical incline with minimal floor space
- Features modular framing for future add-on capability and production line changes

## Industrial & Automation Conveyors

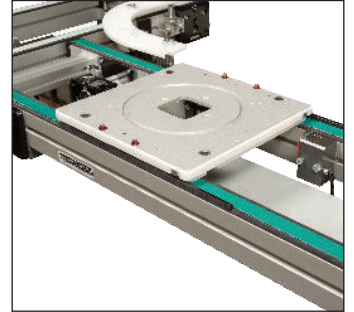
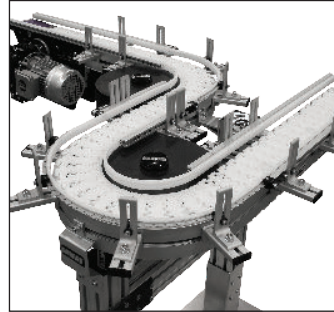
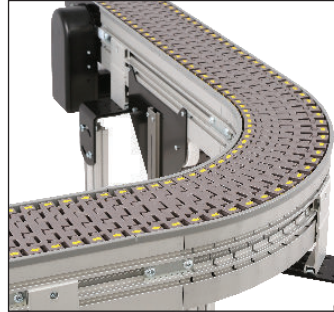
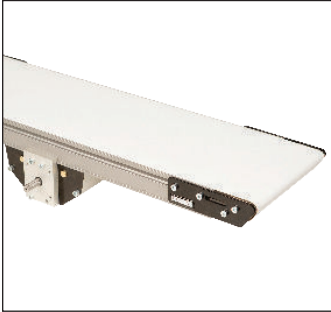

## Sanitary Conveyors

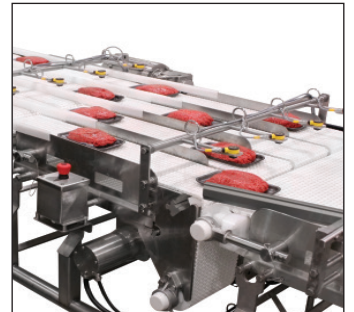
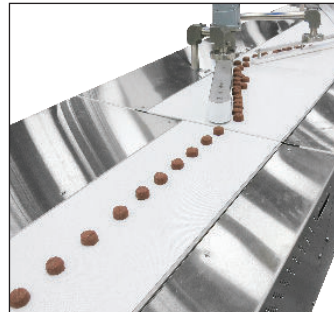
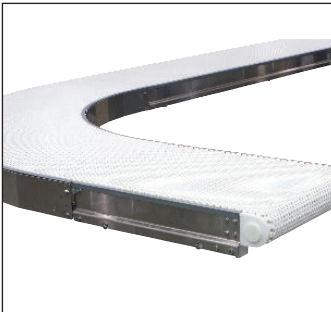

## Engineered Solutions



**Parts**



**Service**



**Online Configurator**



**Warranty**