

AVS



GOYEN

FLANGED VALVES

PENTAIR CLEAN AIR SYSTEMS

GOYEN 'FS' SERIES

PULSE JET VALVES



FS Series

DESCRIPTION

Very high performance diaphragm valve with flanged inlet port and slide seal outlet port for easy valve installation and removal. Available with integral pilot or as remotely piloted valve. Outlet at 90° to inlet.

SUITABLE FOR

Dust collector applications, in particular for reverse pulse jet filter cleaning and its variations, including bag filters, cartridge filters and envelope filters, ceramic filters and sintered metal fibre filters.

CONSTRUCTION

Body: Diecast aluminium or 316 stainless steel
Ferrule: 305 SS
Armature: 430FR SS
Seals: Nitrile or Viton
Spring: 304 SS
Screws: 302 or 304 SS
Outlet Slide Seal: EPDM or Viton
Diaphragm Seat: PA-66 (standard), Viton coated mild steel

Refer to Q Series Solenoid product data sheet for solenoid construction details.

OPERATION

Recommended on-time range: 50–500 ms
Recommended time between pulses: 1 minute or greater

MAINTENANCE

Before conducting any maintenance activity on the system ensure that components are fully isolated from pressure and power supplies. Pressure and power should not be reapplied until the valve has been fully assembled.

Diaphragm and pilot inspection should be conducted annually.

APPROVALS

- ATEX II 3 GD (RCA/RCAC only)
- CSA (C, US) [C22.2 No 139–10 and UL 429:2009] [CA & RCA]
- C-Tick [CA]

- EMC 2004/108/EC (CA)
- Low Voltage Directive 2006/95/EC (CA)

INSTALLATION

1. Prepare inlet flanges and blowtube pipes to suit valve specification. Avoid installing valves underneath the tank.
2. Ensure tank and pipes are free from dirt, rust or other particulate.
3. Ensure supply air is clean and dry.
4. Mount valves to inlet flange and blowtube to valves with all seals in place. Tighten flange bolts to 10Nm (7.4 ft-lbs) Ensure blowtube is pushed all the way into the valve outlet.

5. Tanks and pipes must be independently supported from valve.
6. Make electrical connections to solenoid or connect RCA pilot port to pilot valve (RCA valves only).
7. Apply moderate pressure to system and check for installation leaks.
8. Fully pressurise system.
9. Test fire and listen for proper actuation and crisp pulse noise.

Valve is not a structural component. Do not rely on valve to retain tanks or pipe.

Where used, refer to DEINC-002 product specification for installation details.

SIZE	OD mm	OD inches
1.5"	48.3	1.900

We recommend Schedule 40 thickness.

WEIGHTS

SIZE	INTEGRAL PILOT (CA) kg (lb)	REMOTE PILOT (RCA) kg (lb)
45	1.830 (4.03)	1.610 (3.55)

MAINTENANCE KITS

MODEL	NITRILE	VITON	INCLUDES
CA/RCA45FS	K4502	K4503 K4542 (Viton/SS) K4544 (Viton/SS Main Diaphragm only)	Diaphragm kits include main and secondary diaphragms and all springs.
CAC45FS to CA45FS Integral pilot cover conversion kit	K4532(NPT) K4538(RC)	K4537(NPT) K4539(RC)	The complete CA integrally piloted valve cover assembly. Does not include cover bolts or main bleed pin.
RCAC45FS to RCA45FS Remote pilot cover conversion kit	K4533(RC) K4535(NPT)	K4534(RC) K4536(NPT) K4543 (NPT/SS)	The complete RCA remotely piloted valve cover assembly with main diaphragm and spring. Does not include cover bolts or main bleed pin.
Integral pilot repair kit (CA45FS and CAC25FS)	K0380	K0384	O-ring armature assembly, armature spring, ferrule.
Integral pilot repair kit (CAC45FS)	K0390	N/A	O-ring armature assembly, armature spring, ferrule.
45FS Outlet seal	G690864	G690864-2	Outlet seal

GOYEN 'FS' SERIES

PULSE JET VALVES

PRODUCT CHARACTERISTICS AND PERFORMANCE

NOM. SIZE	PORT SIZE		NUMBER OF DIAPHRAGMS	FLOW		PRESSURE RANGE kPa (psi)	TEMPERATURE RANGE °C °(F)	
	mm	in		KV	CV		NITRILE SEALS	VITON SEALS
45	40	1.5	2	56	65	30(5)–860(125)	–40(–40) to 82(179.6)	–29(–20.2) to 232(449.6)

ORDER CODE

RCA 45 FS 0 1 0 301

Pilot type

RCA=remotely piloted
CA=integral pilot

Valve size

45 mm

Pilot size

0=1/8" or CA
1=1/4"

Solenoid type

Coil type for CA only.
See the RCA3 Solenoid Pilot Valves
brochure for coil options.

Diaphragm material

0=Nitrile
1=Viton

Pilot thread type (RCA), Exhaust thread (CA)

0=NPT
1=RC
9=NPT and stainless-steel valve body

Examples: CA45FS010-300

1.5" FS valve with nitrile seals and 220/240 V AC integral pilot with DIN socket terminals.

RCAC45FS091

1.5" FS valve with 1/8" NPT remote pilot port, stainless steel body and valve cover, and viton seals.

DIMENSIONS

(Dimensions in mm and [inches])

CA/RCA45FS

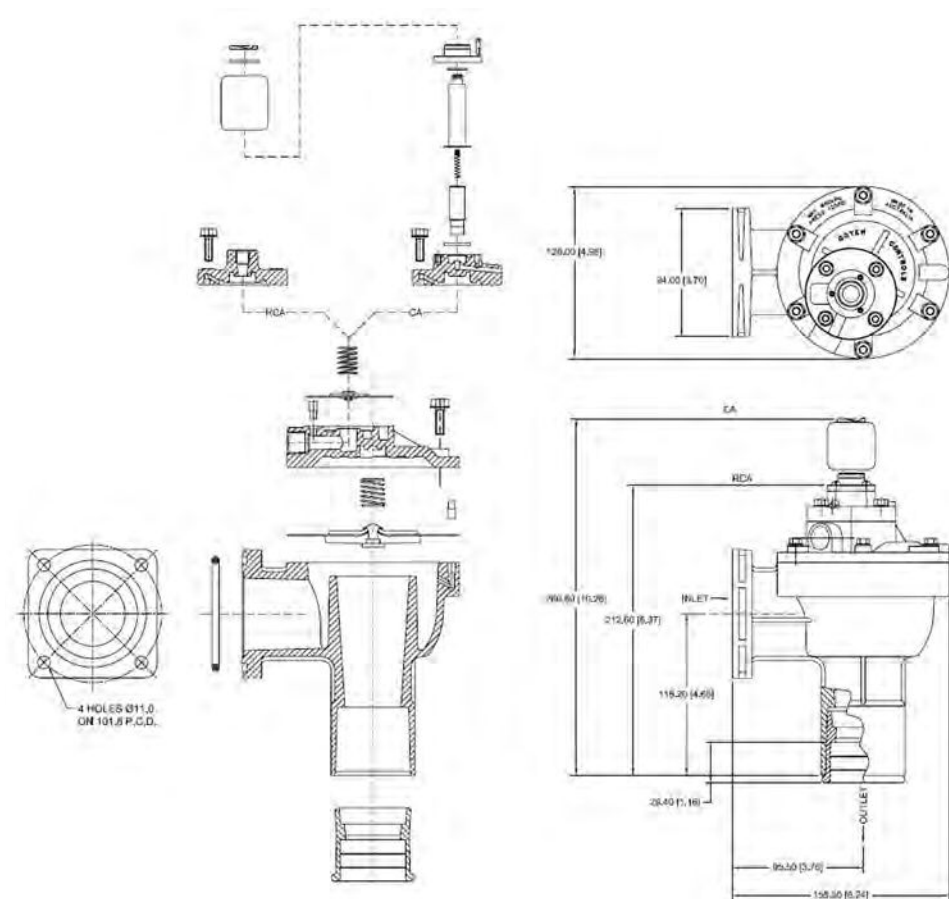

GOYEN RCAC20FS4

REVERSE PULSE JET VALVES



DIMENSIONS

(Dimensions in mm and [inches])

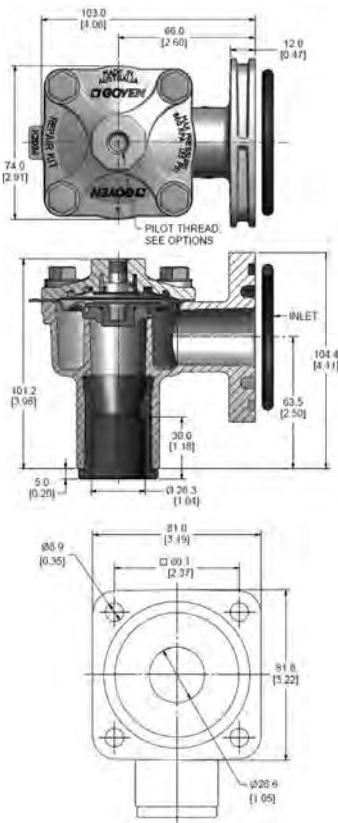

DESCRIPTION

High-performance diaphragm valve with a flanged inlet port and slide seal outlet port. Equipped with 'Shockwave' springless diaphragm. The 4 series valves are available as remote pilot valves and may be converted to integral pilot using either the RCA3DM or RCA3PV screw-in pilots. Outlet is at 90° to inlet. The FS valve range features a larger diameter inlet providing higher performance than the DD, T or ST body styles.

SUITABLE FOR

Dust collector applications, in particular for reverse pulse jet filter cleaning and its variations, including bag filters, cartridge filters and envelope filters, ceramic filters and sintered metal fibre filters.

CONSTRUCTION

Body: Aluminium (diecast)

Screws: 304 Stainless steel

Seals:

Inlet O-ring: Nitrile used with shockwave diaphragm, Viton with Viton diaphragm

Outlet: EPDM used with shockwave diaphragm, Viton with Viton diaphragm

Diaphragm: Proprietary high-performance engineering thermoplastic Elastomer or Viton

OPERATION

Recommended on-time range: 50 to 500 ms

Recommended time between pulses: 1 minute or greater

MAINTENANCE

Before conducting any maintenance activity on the system ensure that components are fully isolated from pressure and power supplies. Pressure and power should not be reapplied until the valve has been fully assembled.

Diaphragm and pilot unit inspection should be conducted annually.

APPROVALS

The RCAC20FS4 meets the requirements of the European Low Voltage Directive 2006/95/EC, when fitted with the RCA3PV pilot.

Please Note: We recommend using Schedule 40 pipe. Thickness OD is as shown below.

SIZE	OD mm	OD inches
3/4"	26.67	1.05

WEIGHTS

VALVE	kg (lb)
RCAC20FS4	0.51 (1.12)

MAINTENANCE KITS

MODEL	SHOCKWAVE	VITON
Diaphragm Kit		
RCAC20FS4	K2034	K2033
20FS4 Outlet Seal		
RCAC20FS4	G690338	G690338-2

PRODUCT CHARACTERISTICS AND PERFORMANCE

NOMINAL PORT SIZE mm (in.)	NO. OF DIAPH.	FLOW KV (CV)	PRESSURE RANGE kPa (psi)	TEMPERATURE RANGE °C (°F)	
				SHOCKWAVE	VITON
20 (3/4)	1	19 (26)	30(5) to 860(125)	-40(-40) to 82(179.6)	-29(-20.2) to 232(449.6)

ORDER CODE

RCAC20FS4	0	1	2
Pilot size	0=1/8"	1=1/4"	
Diaphragm material	1=Viton	2=Shockwave	
Thread type	0=NPT	1=RC	2=G

Examples:

RCAC20FS4012
3/4" FS valve with 1/8" RC pilot port threads, Shockwave diaphragm."

Note:

1/8 Pilot available in NPT, RC and G Thread.
1/4 Pilot is only available in G Thread.

GOYEN RCAC25FS4

REVERSE PULSE JET VALVES



DIMENSIONS

(Dimensions in mm and [inches])

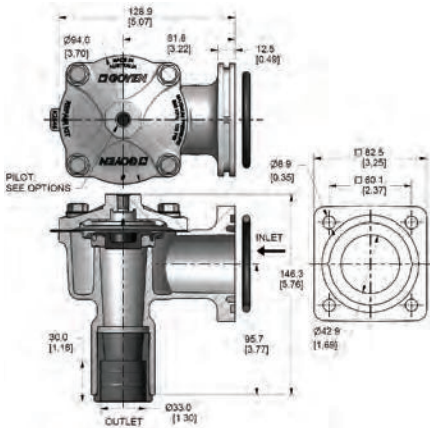

DESCRIPTION

High-performance diaphragm valve with a flanged inlet port and slide seal outlet port. Equipped with 'Shockwave' springless diaphragm. The 4 series valves are available as remote pilot valves and may be converted to integral pilot using either the RCA3DM or RCA3PV screw-in pilots. Outlet is at 90° to inlet. The FS valve range features a larger diameter inlet providing higher performance than the DD or T body styles.

SUITABLE FOR

Dust collector applications, in particular for reverse pulse jet filter cleaning and its variations, including bag filters, cartridge filters and envelope filters, ceramic filters and sintered metal fibre filters.

CONSTRUCTION

Body: Aluminium (diecast)

Screws: 304 Stainless steel

Seals: Nitrile & EPDM or Viton

Diaphragm: Proprietary high-performance engineering thermoplastic Elastomer or Viton

OPERATION

Recommended on-time range: 50 to 500 ms

Recommended time between pulses: 1 minute or greater

Please Note: We recommend using Schedule 40 pipe. Thickness OD is as shown below.

SIZE	OD mm	OD inches
1"	33.4	1.315

WEIGHTS

VALVE	kg (lb)
RCAC25FS4	0.85 (1.87)

MAINTENANCE KITS

MODEL	SHOCKWAVE	VITON
Diaphragm Kit RCAC25FS4	K2546	K2551
FS Outlet Seal RCAC25FS4	G690763	G690763-2

PRODUCT CHARACTERISTICS AND PERFORMANCE

NOMINAL PORT SIZE mm (in.)	NO. OF DIAPH.	FLOW KV (CV)	PRESSURE RANGE kPa (psi)	TEMPERATURE RANGE °C (°F)	
				SHOCKWAVE	VITON
25 (1)	1	34 (40)	30(5) to 860(125)	-40(-40) to 82(179.6)	-29(-20.2) to 232(449.6)

Examples:

RCAC25FS4012

1" FS valve with 1/8" RC pilot port threads, Shockwave diaphragm.

Note:

1/8" Pilot available in NPT, RC and G Thread.

1/4" Pilot is only available in G Thread.

ORDER CODE

RCAC25FS4	0	1	2
Pilot size			
0=1/8"			
1=1/4"			
			Diaphragm material
			1=Viton
			2=Shockwave
			Thread type
			0=NPT
			1=RC
			2=G

DIAPHRAGM SERVICE KITS

FOR DELETED VALVES

MAINTENANCE KITS

MODEL	NITRILE	VITON	LOW TEMPERATURE -60°C (-76°F) min.	INCLUDES
CA/RCA20FS	K2000	K2007	NA	Diaphragm kits include main and secondary diaphragms (where required) and all springs.
CA/RCA25FS	K2501	K2503	K2504	