

AVS[®]



HEADER TANK SOLUTIONS

10" TANK WITH 2" VALVE

HEADER TANK SOLUTIONS

10" TANK WITH 2" VALVE

FULL IMMERSION SYSTEM

DESCRIPTION

The patented **Mecair** "Full Immersion" System consists of a round header tank with fully integrated diaphragm valves, suitable for dust collector filter applications, in particular for reverse pulse-jet filter cleaning of filter bags, cartridges, envelope filters, ceramic filters and sintered metal fibre filters. The Mecair 500 Series diaphragm valve has been specifically designed to be mounted onto a round header tank. This valve is exclusively a Mecair design and has a worldwide patent. The particular design of the Mecair 500 Series diaphragm valve, allows you to fully optimise the increased flow rate and performance this valve has to offer, and also the simple way in which you

can mount the header tank onto the filter wall, eliminating the excessive weight of the traditional square header tanks. The Mecair header tanks are manufactured and tested 100%, in accordance with global pressure vessel certificate [CE PED or ASME certified].

STANDARD CARBON STEEL PAINT SPECIFICATION

Abrasive cleaning, degreasing and paint preparation

Undercoat RAL 7042: 25 microns

Final colour RAL 5012: 25 microns

Total thickness 50 microns (-10%/+40%)

FULL IMMERSION STAINLESS STEEL

DESCRIPTION

The Mecair 500 Series diaphragm valve is manufactured from diecast aluminium and is anodised. The valves are mounted on a painted carbon steel, stainless steel or aluminium tank.

TANK PREPARATION SPECIFICATION

Abrasive cleaning and degreasing

Immersed in acid bath to remove any and all unnatural properties (pickling)

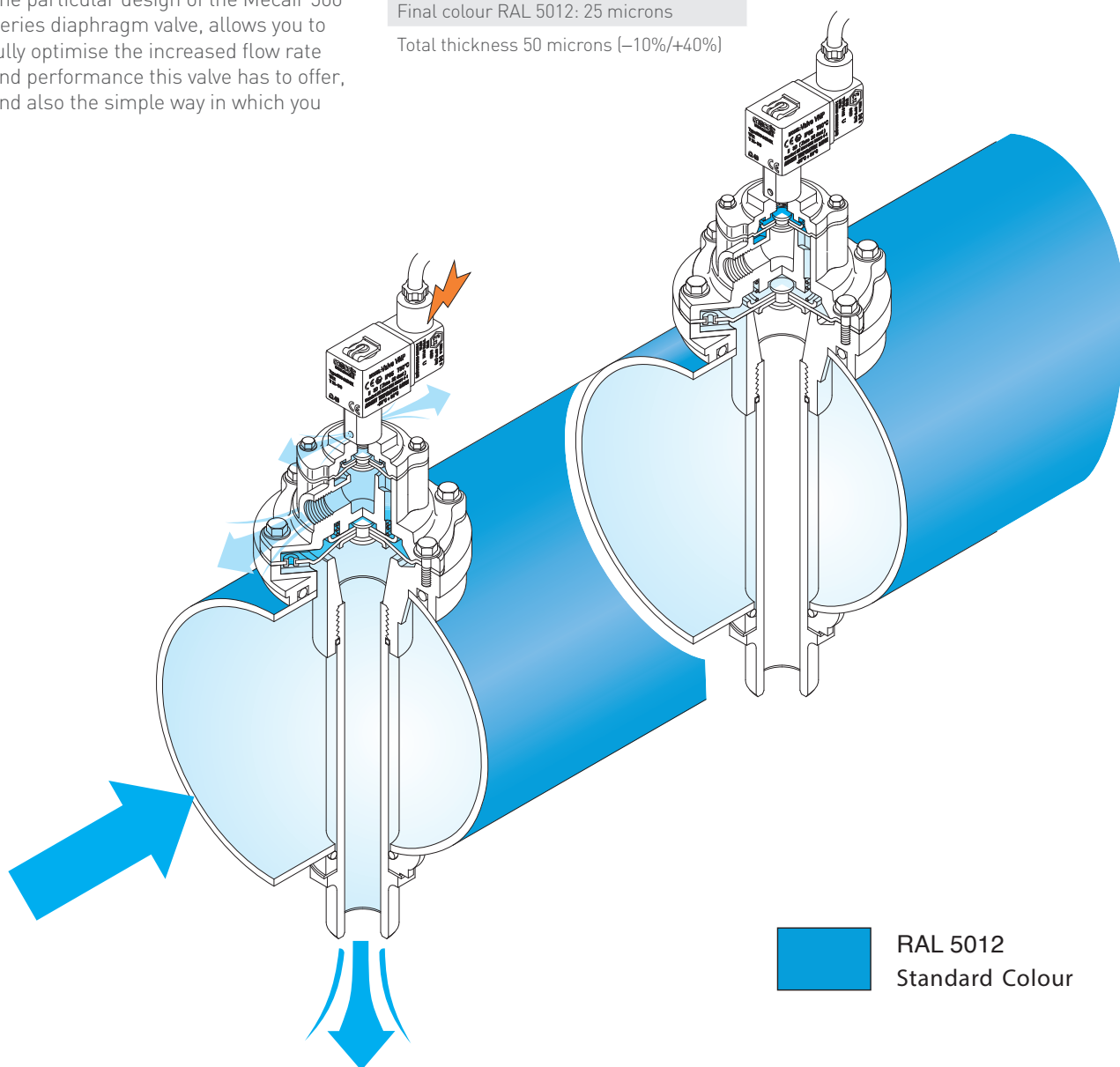

HEADER TANK SOLUTIONS

10" TANK WITH 2" VALVE

CODES AND TECHNICAL CHARACTERISTICS

The 500 Series is available in the following versions:

- **VNP**, with integrated solenoid pilot
- **VEM**, with remote pneumatic connection. (Upon request, the solenoid enclosures can be mounted and pre-cabled on tank.)

CONSTRUCTION FEATURES – VALVE	
Top cover	Diecast aluminium (anodised)
Body	Diecast aluminium (anodised)
Pilot base	Brass (chromed)
Pilot	Stainless steel
Diaphragm	NBR
Bolts	Stainless steel
Diaphragm backing disk	Stainless steel
Diaphragm spring	Alloy steel

ELECTRICAL CHARACTERISTICS – SOLENOID	
Coil insulation	Class H
DIN socket connector	PG9 connection
DIN socket specification	EN175301 - 803 / A/ISO 4400
DIN socket optional	94/9/CE ATEX II 3GD T6
Isolation class DIN socket	VDE 0110 - 1/89
Electrical protection	IP65 EN60529
Voltage range	12 V DC (-5%, +20%) 18 W 24 V DC (-5%, +20%) 18 W 48 V DC (-10%, +20%) 18 W 110 V DC (-10%, +20%) 18 W 24 V 50/60 Hz (-10%, +20%) 38/31 VA 48 V 50/60 Hz (-10%, +20%) 41/32 VA 115 V 50/60 Hz (-10%, +20%) 63/53 VA 220/240 V 50/60 Hz (-10%, +20%) 46/37 VA

GENERAL CHARACTERISTICS	
Fluids	Filtered air and oil free
Diaphragm	Standard: NBR: -20°C/+120°C Viton: -30°C/+200°C
Pressure range	0.5 to 7.5 bar

TYPE	PORT SIZE	NO. DIAPH.	PRESSURE RANGE [BAR]		COIL	KV	CV
			min.	max.			
VNP516	2"	2	0.5	7.5	YES	110	128
VEM516	2"	2	0.5	7.5	NO	110	128

HEADER TANK SOLUTIONS

10" TANK WITH 2" VALVE

TANK DIMENSIONS TABLE

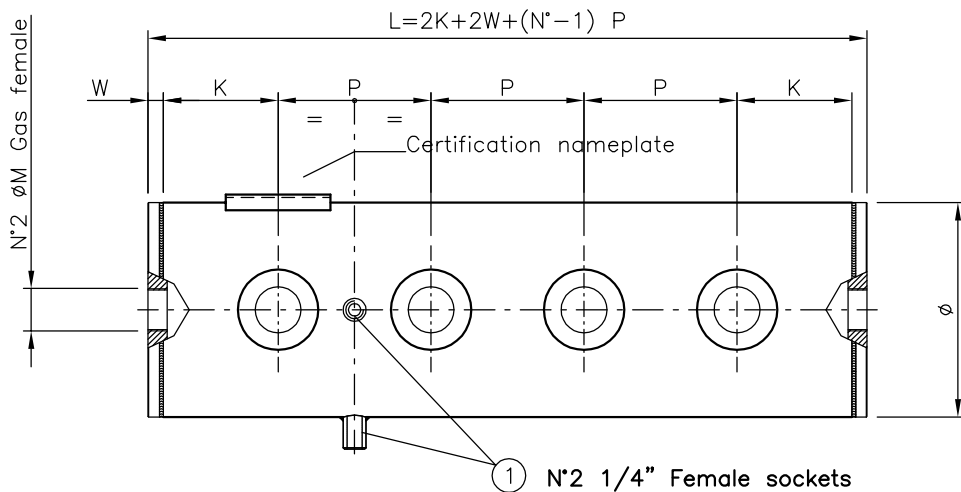

Ø TANK	Ø VALVE	P MIN.	K min.	W	Ø M	TO BE COMPLETED BY CUSTOMER		
						P DISTANCE REQUIRED	N NUMBER OF VALVES	K OPTIONAL
DN10"	2"	180	115	18	1½"			

* Only available with flat end caps and max. length size 4.6 metres. For lengths superior to those specified, please contact our technical department.

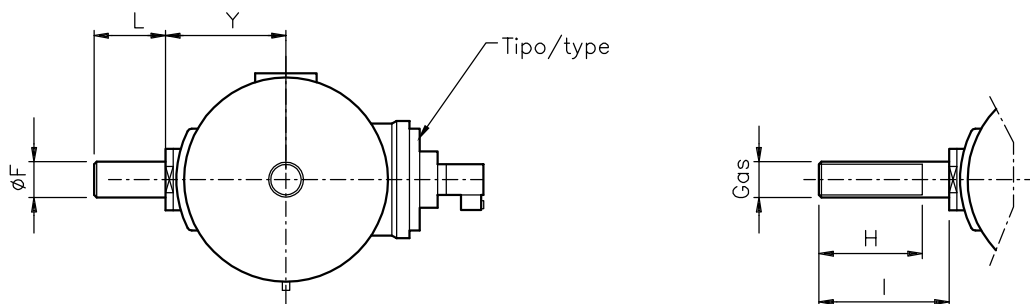

Valve Blowpipe

Ø TANK	Ø F	Y	SHORT UNTHREADED	L	LONG UNTHREADED	L	LONG THREADED	Ø G GAS	H	I
DN 10"	60.3	158	TS516	60	TL516	140	TF516	2"	130	140

HEADER TANK SOLUTIONS

10" TANK WITH 2" VALVE

BRACKET AND BLOWTUBE CONFIGURATIONS

DN TANK	TYPE OF BRACKET	A	B	H
10" (273)	TH10	424	250	290
	TB10	424	250	161

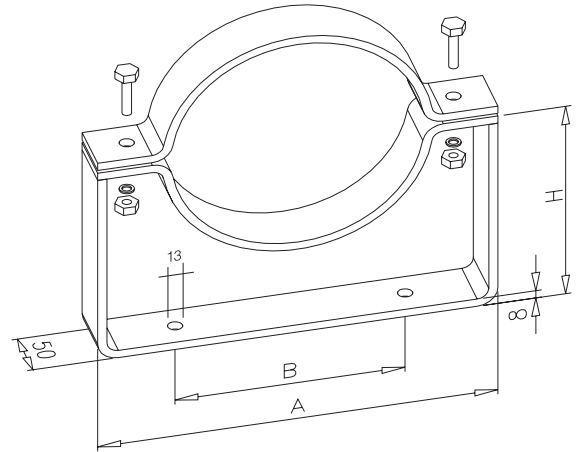

DN TANK	TYPE OF BRACKET	VALVE BLOWPIPE	E	D max.	VALVE BLOWPIPE	E	D max.
10" (273)	TH10				TL516	280	550
	TB10				TL516	280	550

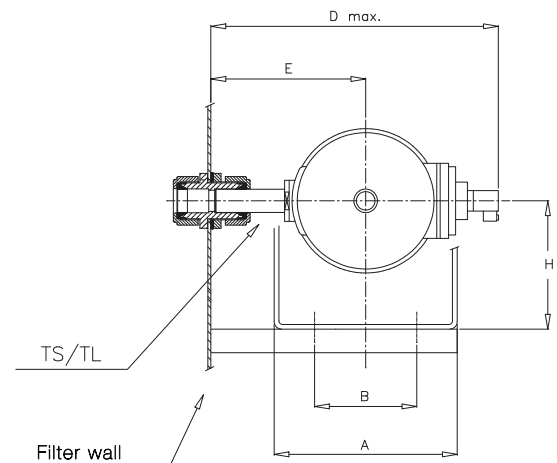

DN TANK	TYPE OF BRACKET	D max.	VALVE BLOWPIPE	Ø
10" (273)	TH10	560	TL516	2"

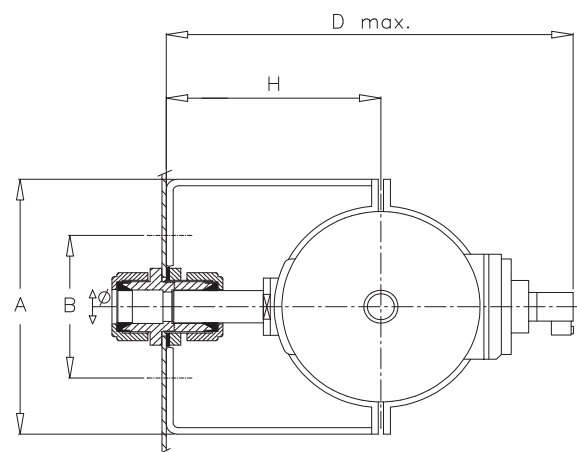

HEADER TANK SOLUTIONS

10" TANK WITH 2" VALVE

TANK ASSEMBLY TABLE

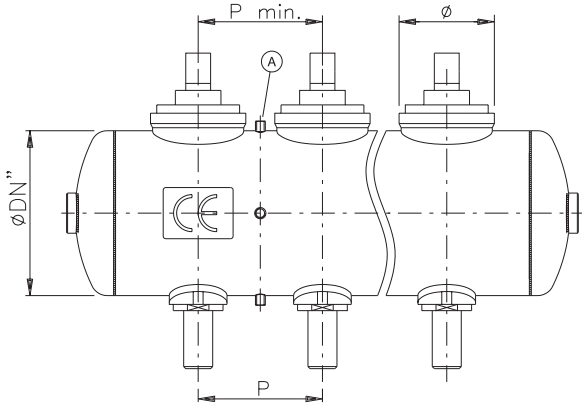

Ø TANK	P min.	Ø VALVE BODY	P min. FOR INSTALLATION OF STANDARD BRACKETS	P min. PIPE STUB A
DN 10" (273)	180	170	230	200

OPERATING RECOMMENDATIONS

Ensure air supply is clean and dry. (We recommend the installation of compressed-air filter units to be installed directly before the pressure vessel, in order to ensure clean and dry air is supplied to the diaphragm valve). Operating pressure min./max. 0.5–7.5 bar.

- a) **AIR INLET PIPE TO HEADER TANK/ PRESSURE VESSEL:** Minimum Ø 1" for tanks with a 1" valve or 1½" valves. We always recommend the air inlet pipe to tank to be the

same size as the diameter of valve being used, or the next available size down. This ensures that the air supply to the tank is sufficient to allow the tank to refill in as short a time as possible. With the correct volume of air in the tank, this ensures the correct and efficient functioning of the diaphragm valve without any waste of compressed air.

- b) **ORIENTATION:** Can work in all orientations.

- c) **ELECTRICAL ON TIMES AND PULSE TIMES:** For the correct and efficient use of a diaphragm valve, it is important to set the correct pulse times and pause times. Average pulse times range from 100 ms–250 ms depending on size of the valves being used. Pause times also depend on number of valves in the filter, but MECAIR recommends a total cycle time of between 300 and 360 seconds for the total number of valves installed.

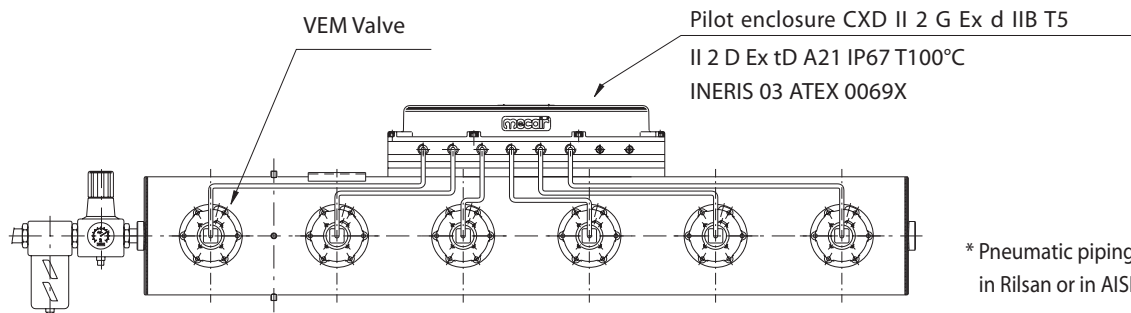
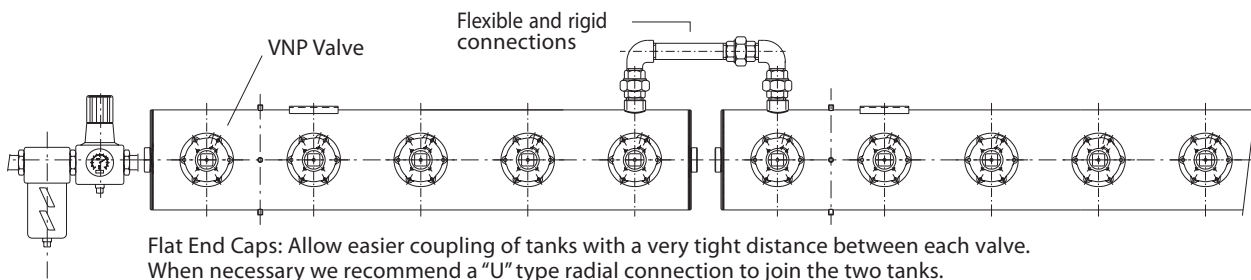

* Pneumatic piping on valves can be in Rilsan or in AISI (stainless steel)

HEADER TANK SOLUTIONS

10" TANK WITH 2" VALVE

SPARE PARTS

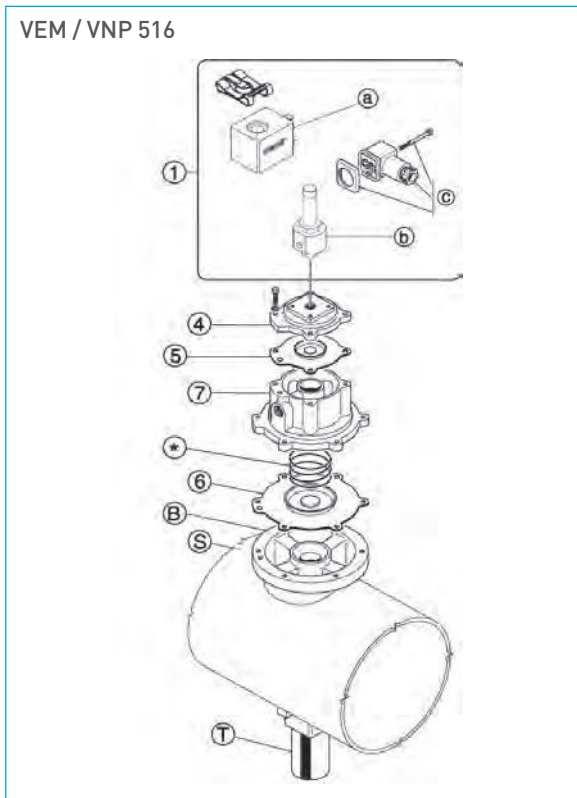

* Code for Spring **M470568** for model **VEM/VNP 512-514-516-520-524**
 For **VEM/VNP506-508-512** with Viton diaphragm, code for spring **M470200**
 [Valve Body(B) + Tank(S) + Valve blowpipe (T) are to be considered single and complete module.] [No spare parts available for this configuration.]

STANDARD VERSION

POS	DESCRIPTION	CODE
Standard 1	a) Solenoid (*)	a) KIT SB4 - ../.. (*)
	b) Pilot group complete with base and ferrule	b) KIT CP1/4
	c) DIN connector PG9EN175301-803 IP65	c) KIT PLG9

(*) Specify Voltage and Frequency

OPTIONAL VERSION

POS	DESCRIPTION	CODE
Optional 1	a) Solenoid	a) KIT SB4 -24/DCX
	b) Pilot group complete with base and ferrule	b) KIT CP1/4
	c) DIN connector PG9EN175301-803 IP65	c) KIT PLG11 - ATEX

In conformity with 94/9/CE ATEX Directive (cod. KIT PV-24/DCX)

POS	DESCRIPTION	CODE
		VEM/VNP516
1	Pilot group complete with solenoid (*) and DIN connector	KIT PV - ../.. (*)
a+b+4	Pilot group complete with solenoid (*), DIN connector, top cover and screws	KIT PVM06 - ../.. (*)
4	Top cover	KIT M110082
5	Diaphragm	KIT DB 16
6	Diaphragm (secondary)	KIT DB 116
7	Intermediate cover (double diaphragm)	KIT M310100

(*) Specify voltage and frequency.