

Product Data:-



Preface:

With ingredient commodity prices continually increasing more emphasis is being placed on waste reduction. Screening incoming ingredients can be achieved with ease utilising the Eclipse free standing hand ingredient sieve.

Sieving can significantly reduce the risk of introducing the following items into your production facility from incoming goods:

- Glass
- Plastic
- Steel
- Wood
- Insects
- Paper/Card
- Organic Materials

Sieving ingredients can also eliminate the risk of irregular sized product from entering the main production process.

With a sturdy fully welded 316 grade stainless steel frame and 'tilt' wheels, these units are easily moved ensuring increased utilisation of your purchase.

Available in two sizes, we have a sieve to suit your specific requirements. Each unit can also benefit from the incorporation of the optional high intensity magnetic grid that sits beneath the screen. Please refer to data sheet 505.

Cleaning:

Cleaning is both quick and simple. Due to the unit benefiting from only three sections, top pan, sieve screen and base cleaning can be completed in less than 60 seconds.

Suitable Products:

Dry powders, granulates and liquids.

Benefits:

Easy to clean ■ High polished finish ■ Fully mobile ■ Incorporate main isolation switch and On/Off function ■ Compact size ■ Ultra quiet operation ■

Category:

Ingredient Sieving.

Technical Data:-

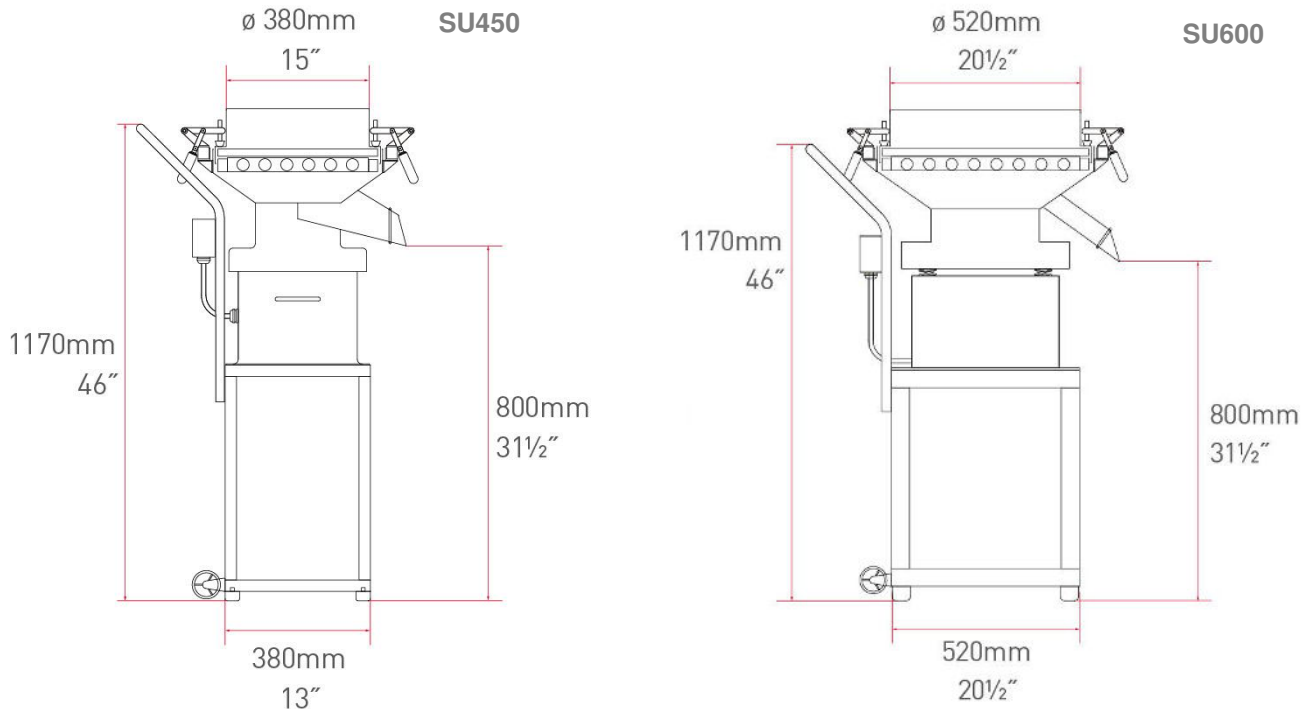

Sizes:-

Part No	Top Pan Capacity Ltrs/Gal	Maximum Throughput Kgs/lbs Per Hour*	Weight Kgs/lbs
SU450	10 / 3	200 / 440	65 / 143
SU600	20 / 6	400 / 880	95 / 209

Performance:-

Operating Voltage:	220 - 240 Volts
Operating Frequency:	50 - 60 Hz
Motor Speed:	1440 RPM
Noise Level:	< 70 dB
Temperature:	5° C - 40° C

*Estimation sieving flour using # 60 screen

Materials:-

Main Body:	316 Grade Stainless Steel
Top Pan:	316 Grade Stainless Steel
Surface Finish:	Highly polished
Sealing:	Silicon, Metal Detectable – Blue, FDA Approved
Thumb Clamps:	304 Grade Stainless Steel

Options:-

- Sieve Magnet 11,000 Gauss
- ATEX Certified
- Larger Top Pan
- Dust Hood
- Dust Hood Incorporating Bag Station