

The main feature of these cups is that they open, and therefore they produce a vacuum, only when the load to be handled activates the sealing ball. In this version, the gripping surface is limited by a silicone O-ring which guarantees the vacuum seal. They have been specially designed for vacuum beds and they are fully made with anodised aluminium.

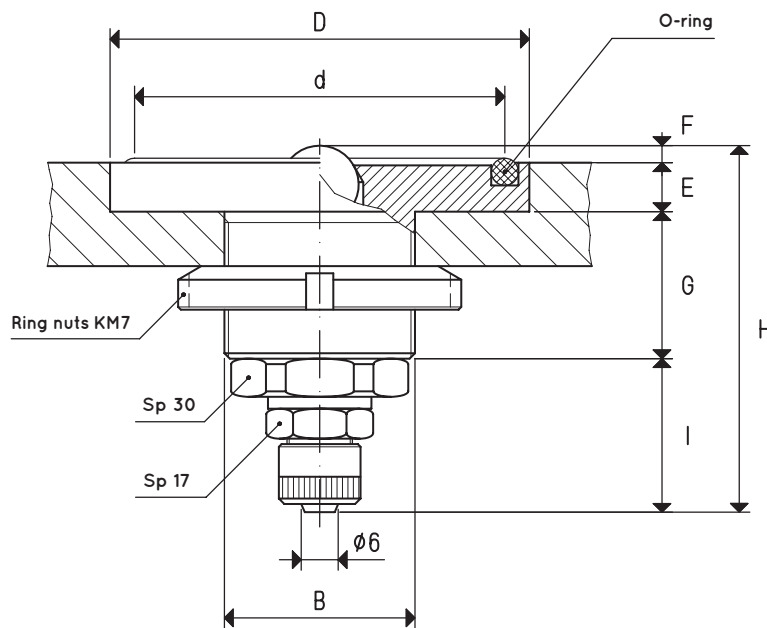

BUILT-IN VACUUM CUPS WITH BALL VALVE

Item	Force Kg	Volume cm ³	B Ø	d Ø	D Ø	E	F	G	H	I	O-ring item	Weight g
05 01 10	9.80	2.1	35 x 1.5	50	59	9	3	27	66	27	00 05 14	248
05 02 10	13.60	3.0	35 x 1.5	59	68	9	3	27	66	27	00 05 15	268
05 03 10	18.10	3.9	35 x 1.5	68	77	9	3	27	66	27	00 05 16	294
05 04 10	29.70	6.3	35 x 1.5	87	96	9	3	27	66	27	00 05 19	358

Note: The force of the vacuum cups indicated in the table represents 1/3 of the value of the theoretical force calculated at a level of vacuum of -75 KPa and a factor of safety 3.

Transformation ratio: N (newton) = Kg x 9.81 (force of gravity) inch = $\frac{\text{mm}}{25.4}$; pounds = $\frac{\text{g}}{453.6} = \frac{\text{Kg}}{0.4536}$

The main feature of these cups is the same as described above; they differ only in the seal which, in these, consists of the flat vacuum cups listed in the table.

They are especially designed for the glass industry vacuum and in all those cases where the use of a magnetic plane is not possible.

They are made of anodised aluminium but can be manufactured with other metals upon request.

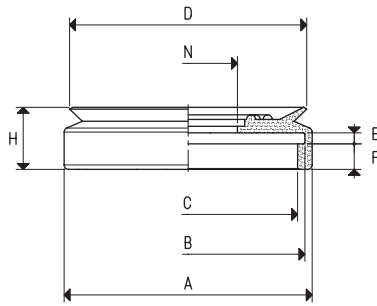

SPARE VACUUM CUP

Item	Force Kg	Volume cm ³	A Ø	B Ø	C Ø	D Ø	E	F	H	N Ø	Weight g
01 65 15 *	8.29	9.1	68	63	59	65	3	7	17	27	21.4

* Complete the code indicating the compound: A= oil-resistant rubber; N= natural para rubber; S= silicone

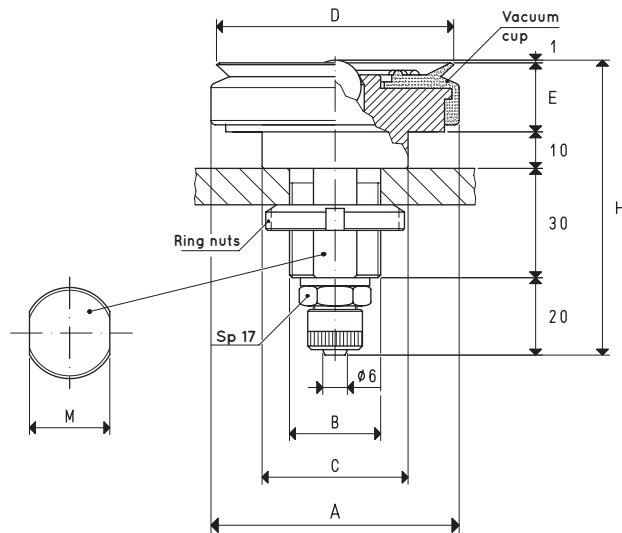

BUILT-IN VACUUM CUPS WITH BALL VALVE

Item	Force Kg	A Ø	B Ø	C Ø	D Ø	E	H	M	Ring nut	Vacuum cup item	Weight g
05 65 15 *	8.29	69	25 x 1.5	40	65	19	80	22	KM 5	01 65 15	262

* Complete the code indicating the compound: A= oil-resistant rubber; N= natural para rubber; S= silicone

Note: The force of the vacuum cups indicated in the table represents 1/3 of the value of the theoretical force calculated at a level of vacuum of -75 KPa and a factor of safety 3.

Transformation ratio: N (newton) = Kg x 9.81 (force of gravity) inch = $\frac{\text{mm}}{25.4}$; pounds = $\frac{\text{g}}{453.6} = \frac{\text{Kg}}{0.4536}$

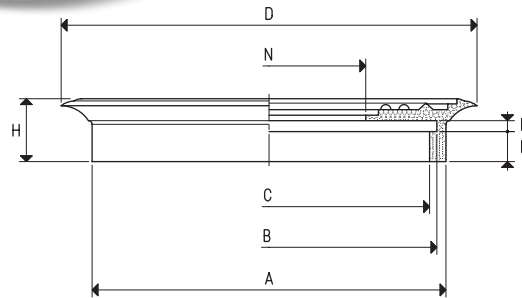

SPARE VACUUM CUPS

Item	Force Kg	Volume cm ³	A Ø	B Ø	C Ø	D Ø	E	F	H	N Ø	Weight g
01 85 15 *	14.18	13.0	68	63	59	85	3	7	17	27	29.7
01 110 10 *	23.74	24.9	96	91	87	114	3	8	17	54	44.3
01 150 10 *	45.00	75.7	133	125	118	154	4	11	23	64	112.0

* Complete the code indicating the compound: A= oil-resistant rubber; N= natural para rubber; S= silicone

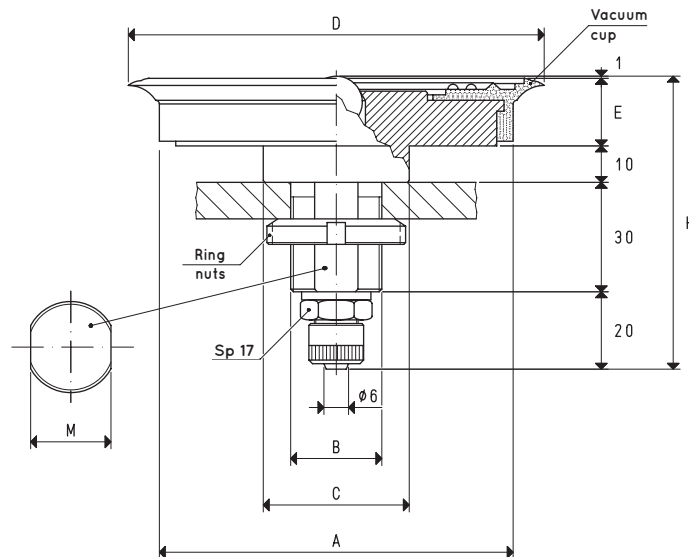

BUILT-IN VACUUM CUPS WITH BALL VALVE

Item	Force Kg	A Ø	B Ø	C Ø	D Ø	E	H	M	Ring nut	Vacuum cup item	Weight g
05 85 15 *	14.18	69	25 x 1.5	40	85	19	80	22	KM 5	01 85 15	272
05 110 10 *	23.74	97	25 x 1.5	40	114	19	80	22	KM 5	01 110 10	422
05 150 10 *	45.00	135	35 x 1.5	80	154	25	86	32	KM 7	01 150 10	894

* Complete the code indicating the compound: A= oil-resistant rubber; N= natural para rubber; S= silicone

Note: The force of the vacuum cups indicated in the table represents 1/3 of the value of the theoretical force calculated at a level of vacuum of -75 KPa and a factor of safety 3.

Transformation ratio: N (newton) = Kg x 9.81 (force of gravity) inch = $\frac{\text{mm}}{25.4}$; pounds = $\frac{\text{g}}{453.6} = \frac{\text{Kg}}{0.4536}$