

These cups have been designed for handling cylindrical objects, such as pipes, bottles, round profiles, etc. Its aluminium support is vulcanised onto the cup and it is provided with a central threaded hole to ease its fastening to the machine and with a side hole for the possible insertion of a guiding, anti-rotation pin.

These cups can be provided in the three standard compounds: oil-resistant rubber A, natural para rubber N and silicon S.

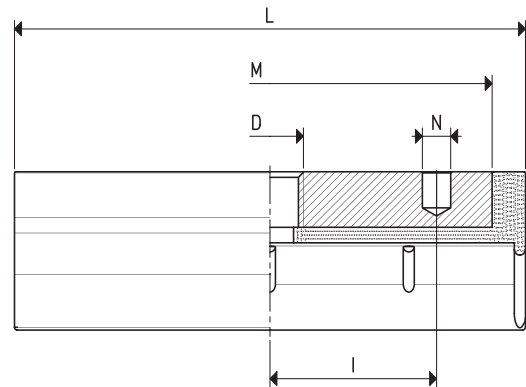
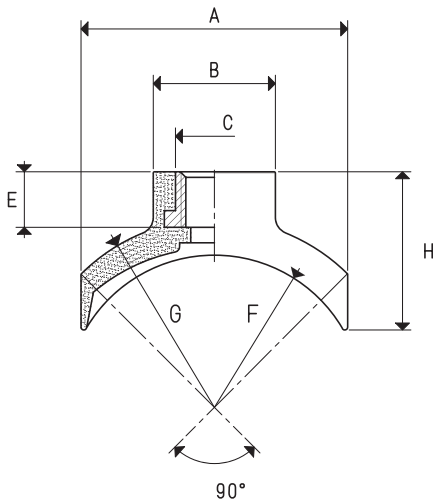

CONCAVE CUPS WITH VULCANISED SUPPORT

Art.	Force Kg	gripping Ø		A	B	C	D Ø	E	F	G	H	I	L	M	N Ø	Support material	Weight g
		min	max														
08 30 60 *	3.5	30	45	26	15	10	M8	8	16	19	20.0	20	60	50	4.1	aluminium	20.3
08 40 90 *	8.6	50	80	40	20	14	M12	10	23	28	25.0	30	92	80	5.1	aluminium	54.8
08 50 90 *	10.5	60	95	48	22	14	M12	10	28	34	28.5	30	92	80	5.1	aluminium	62.5

* Complete the code indicating the compound: A= oil-resistant rubber; N= natural para rubber; S= silicon

$$\text{Conversion ratio: inch} = \frac{\text{mm}}{25.4}; \text{ pounds} = \frac{\text{g}}{453.6} = \frac{\text{Kg}}{0.4536}$$