

E2 Systems specialise in the design and production of Drilling and Tapping units and pneumatics/hydraulics according to customer specification. Our business is based on long experience and cutting-edge competence within the hydraulic and pneumatic technologies. The products are of compact design in order to offer high performance and save space.

E2 products are in operation in practically every country around the world through distribution by E2's representatives or delivery as vital components of other manufacturers' equipment.

A large portion of E2 products are used in the automotive industry, but they can also be found in other manufacturing industries as well as the woodworking industry. Our customers include: Electrolux, General Motors, Getinge, Honda, Kinnarps, Rolls Royce, SKF and Volvo.

COST-EFFECTIVE AUTOMATION

COMPACT UNITS FOR

- DRILLING
- TAPPING
- MILLING

You will find units for Drilling, Tapping and Milling installed wherever increased rates of production are required. They are a cost-effective means of automating drilling, tapping and milling operations.

E2 products are known world wide for their quality, durability, precision and power. Each series of E2 units are the most compact in the market today.

E2 customers benefit from the high quality of the E2 product line with less down-time and reduced operating costs. The compact design of the E2 units together with a good availability of CAD-drawings/-models makes the design of a machine more straight forward.

E2's concern for the worker and his environment is evident in all E2 products. Low noise levels and non-lubrication features eliminating oil mist in the air is a common feature of the E2 product line.

E2 self-feeding units utilizes a built-in hydraulic feed control system. They combine precision with power enabling a high level of precision also in multi-spindle head applications. The extremely compact Air hydraulic drilling units and Lead screw tappers are ideal for drilling/tapping smaller holes. E2's electro-pneumatic and -hydraulic units can to be used when more power is required. You will still have the E2 durability and precision. The E2 product line also includes non-feed pneumatic units perfect for drilling as well as milling, slitting and grinding.

Complementing the line of units, E2 also offers a full line of accessories for machining applications.

E2 also have supplementary product lines of

- Rotary actuators
- Air thrusters
- Pneumatic/Hydraulic components and systems



CONTENTS

Drilling Units	4–25
Tapping Units	26–33
Milling Units	34–37
Multi-spindle Heads	38–46
Tool Holders	47–50
Controls	51–56

DRILLING UNITS

E2 drilling units can be found throughout the world wherever a high level of productivity and precision is vital. A long service life with excellent reliability and continued precision makes E2's drilling units a good investment.

E2 drilling units range from compact pneumatic units to power packs with electrically-operated spindles and integrated hydraulic systems. E2 units are easy to install as well as use, and have functions such as quick advance, controlled working feed, multi-wall drilling and chip-removal. Most are available with multi-spindle heads.

Each drilling unit's details include all the necessary information for selecting a suitable model based on the requirements set by your drilling application and the cutting data specified by your drill supplier. In addition to performance specifications, you will also find information on dimensions, necessary components and accessories.

To provide a quick summary, there are also guidelines for the capacities of the various models, based on conventional drills, in the most common materials.

DRILLING UNITS

UNIT	PAGE	DRIVE	FEED	DRILLING CAPACITY IN [ø, mm]		
				STEEL	ALUMINIUM/ BRASS	PLASTICS/ WOOD
BE11 and HFS100	6	Pneumatic Turbine	None	1,5	3	4
BE22SK	8	Pneumatic 5-vane Motor	None	8	12	22
BEP22SK	10	Pneumatic 5-vane Motor	None	6	9	14
BE33SK	12	Pneumatic 5-vane Motor	None	13	16	26
BE(S)21	14	Pneumatic 5-vane Motor	Pneumatic	6	11	16
BE(F)22	16	Pneumatic 5-vane Motor	Controlled, Air Hydraulic	6	11	16
BE(F)P22	18	Pneumatic 5-vane Motor	Controlled, Air Hydraulic	5	9	12
BE33	20	Pneumatic 5-vane Motor	Controlled, Air Hydraulic	10	14	20
BE48	22	Electric	Controlled, Air Hydraulic	16	25	35
BE55	24	Electric	Controlled, Hydraulic	25	35	40

HIGH PRECISION DRILLING UNIT BE11 AND HIGH SPEED GRINDER HFS100

Precision drilling/grinding unit with a basic design based on a patented air-driven turbine motor. The drive unit is powered without intermediate gears and features variable speed control up to 80 000 rpm. A special high-speed precision bearing makes the drilling unit extremely quiet with a sound level of 67 dB (A). BE 11 / HFS 100 is designed for lubrication-free operation.

- 80 000 RPM
- PRECISION UNIT FOR DRILLING, DEBURRING ETC
- HIGHLY STABLE BEARING SYSTEM
- LOW NOISE LEVEL (67 dB(A))
- HFS 100: ALSO AVAILABLE AS HIGH SPEED GRINDER (HFS100), WHICH INCLUDES A HOSE SUITABLE FOR MANUAL HANDLING OF THE UNIT (SEE PICTURE).



Guidelines for choice of unit				[Ø, mm]
DRILLING UNIT	CAPACITY IN STEEL	CAPACITY IN ALUMINIUM/BRASS	CAPACITY IN WOOD/PLASTICS	
BE 11	1.5	3	4	

Performance specifications at 6.3 bar					
Power	0.08 kW	Min. CC Spindle Spacing	54 mm	Air consumption	<0.12 Nm ³ /min
Speed	<80 000 rpm	Run-out at spindle nose (max.)	0.007 mm	Sound level	67 dB(A)
Torque	0.02 Nm	Working pressure range	4–6.3 Bar		

Dimensions [mm]

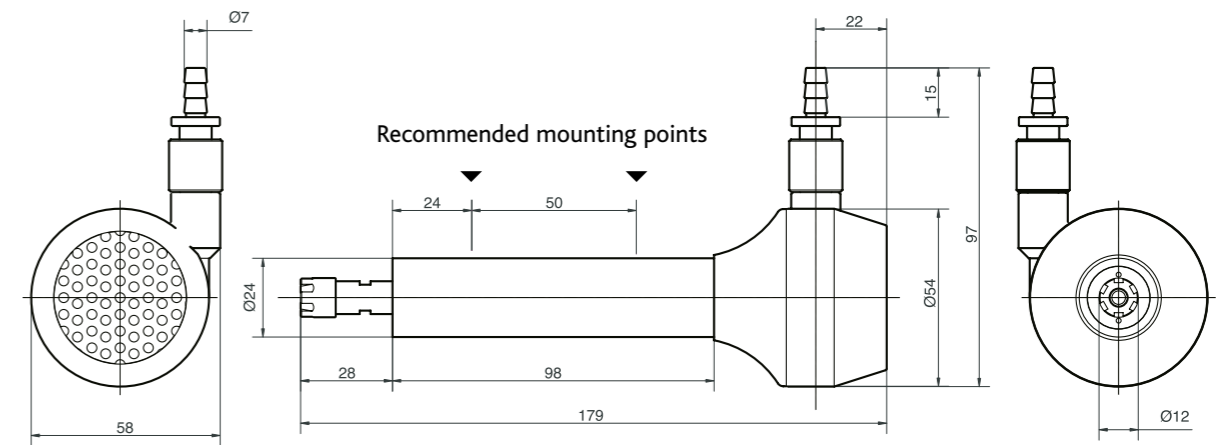

You can download 2D CAD-drawings and 3D CAD-models on www.e2systems.com.

WEIGHT 0.45 KG

Necessary components		
COLLETS	TYPE	PAGE
	ER 8 collets 1.0 – 5.0 mm	47

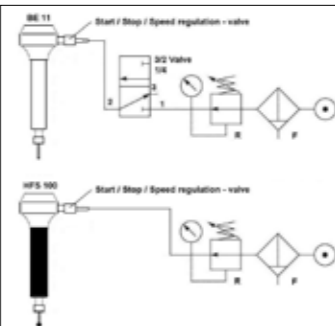
Accessories		
CONTROLS	TYPE	PAGE
	Controls for BE 11/HFS 100	51

PNEUMATIC DRILLING UNIT BE 22 SK

The BE 22 SK consists of an air motor, a gear box and a body. The design is compact as well as robust. BE 22 SK comes in a wide range of speeds, and is available for lubrication-free operation.

- STURDY AND COMPACT DESIGN
- WIDE RANGE OF RPMs
- DIRECTED EXHAUST
- CHUCK ALTERNATIVES UP TO Ø20 MM
- IS AVAILABLE IN COUNTER CLOCKWISE ROTATION



Guidelines for choice of unit [Ø, mm]

DRILLING UNIT	CAPACITY IN STEEL				CAPACITY IN ALUMINIUM/BRASS				CAPACITY IN WOOD/PLASTICS			
	1	2	3	4	1	2	3	4	1	2	3	4
LOW SPEED												
BE 225 SK	8	6	5	4	12	9	8	7	22	11	9	8
BE 228 SK	8	5	5	4	12	9	8	7	20	11	9	7
BE 2211 SK	6	4	4	4	10	8	7	6	16	11	9	7
HIGH SPEED												
BE 2222 SK	6	3	3	3	9	7	6	5	14	9	8	6
BE 2236 SK	5	2.5	2.5	2	8	6	6	5	12	8	7	5
BE 2249 SK	4	1.5	1.5	1.5	6	5	5	4	10	6	6	4
BE 22220 SK	2				3				4			

Performance specifications at 6.3 Bar

Power	0.25 kW	Run-out at spindle nose (max.)	0.03 mm	Air consumption	<0.3 Nm ³ /min
Min. Center to Center Spacing		Working pressure range	6-7 Bar	Sound level	70 dB(A)
Single Spindle	45 mm				
Double-Spindle Head	11 mm				

DRILLING UNIT	SPEED (IDLE) [RPM]	SPEED (AT MAX OUTPUT) [RPM]	TORQUE (AT MAX OUTPUT) [NM]
LOW SPEED			
BE 225 SK	500	250	9.9
BE 228 SK	800	400	6.0
BE 2211 SK	1 100	550	4.3
HIGH SPEED			
BE 2222 SK	2 200	1 100	2.4
BE 2236 SK	3 600	1 800	1.5
BE 2249 SK	4 900	2 450	1.1
BE 22220 SK	22 000	11 000	0.25

Dimensions [mm]

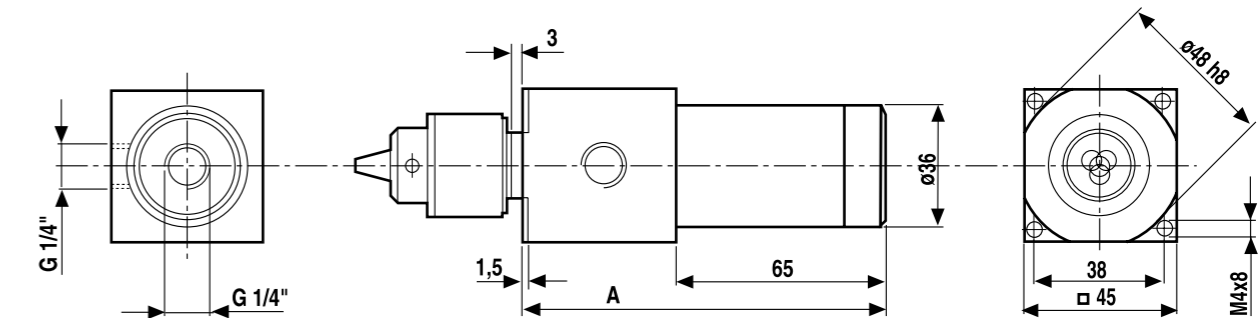

You can download 2D CAD-drawings and 3D CAD-models on www.e2systems.com.

DRILLING UNIT	A [MM]	WEIGHT [KG]
LOW SPEED		
BE 225 SK	141	1.5
BE 228 SK		
BE 2211 SK		
HIGH SPEED		
BE 2222 SK	109	0.9
BE 2236 SK		
BE 2249 SK		
BE 22220 SK		

Necessary components

CHUCKS	TYPE	PAGE
	Key chucks Ø 0.5-6.5 mm (Standard chuck) Ø 0.8-10.0 mm	47
	Collet Chucks ER11 Ø 1.0-7.0 mm ER20 Ø 1.0-13.0 mm ER32 Ø 2.0-20.0 mm	47
COLLETS	TYPE	PAGE
	ER11 Ø 1.0-7.0 mm ER20 Ø 1.0-13.0 mm ER32 Ø 2.0-20.0 mm	47

Accessories

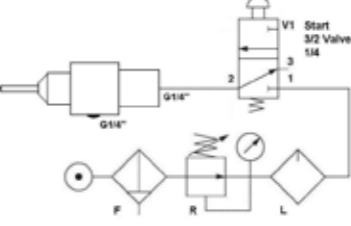
MULTI-SPINDLE HEADS	TYPE	PAGE
	Adjustable heads VH04, VH06	38
CONTROLS	TYPE	PAGE
	Controls for BE SK-units	51

PNEUMATIC PRECISION DRILLING UNIT BEP 22 SK

The BEP 22 SK is a precision drilling unit, equipped with a precision chuck. Thanks to separate and double ball bearings run-out amounts to a maximum of 0.01 mm. Its design is compact as well as robust. The BEP 22 SK comes in a wide range of speeds, and is available for lubrication-free operation.

- HIGH PRECISION
- STURDY AND COMPACT DESIGN
- WIDE RANGE OF RPM:s
- DIRECTED EXHAUST



Guidelines for choice of unit [Ø, mm]			
DRILLING UNIT	CAPACITY IN STEEL	CAPACITY IN ALUMINIUM/BRASS	CAPACITY IN WOOD/PLASTICS
BEP 2222 SK	6	9	14
BEP 2236 SK	5	8	12
BEP 2249 SK	4	6	10
BEP 22220 SK	2	3	4

Performance specifications at 6.3 Bar					
Power	0.25 kW	Run-out at spindle nose (max.)	0.01 mm	Air consumption	<0.3 Nm ³ /min
Min. CC Spindle Spacing	45 mm	Working pressure range	6–7 Bar	Sound level	70 dB(A)

DRILLING UNIT	SPEED (IDLE) [RPM]	SPEED (AT MAX OUTPUT) [RPM]	TORQUE (AT MAX OUTPUT) [NM]
BEP 2222 SK	2 200	1 100	2.4
BEP 2236 SK	3 600	1 800	1.5
BEP 2249 SK	4 900	2 450	1.1
BEP 22220 SK	22 000	11 000	0.25

Dimensions [mm]

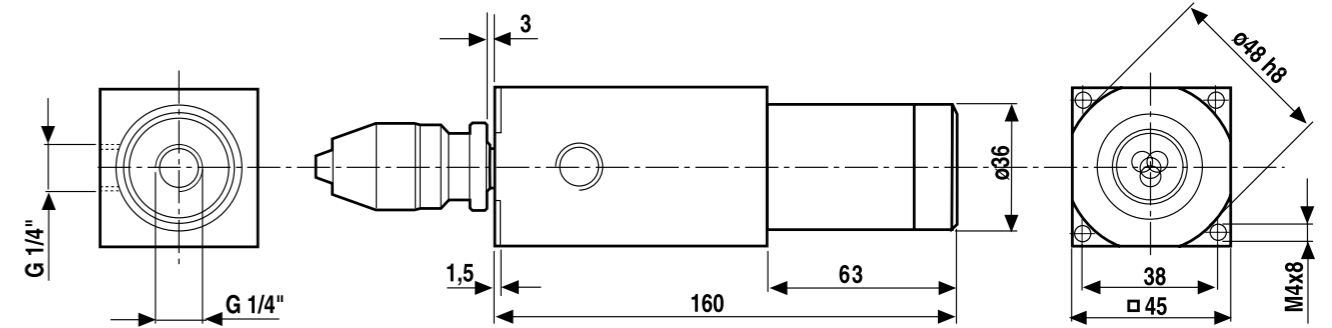

You can download 2D CAD-drawings and 3D CAD-models on www.e2systems.com.

WEIGHT 1.7 KG

Necessary components

CHUCKS	TYPE	PAGE
	Precision chucks Ø 0–3.0 mm Ø 0–5.0 mm (Standard chuck) Ø 0–8.0 mm	47
	Precision Collet Chuck ER 11 Ø 0.5–8.0 mm	47
COLLETS	TYPE	PAGE
	ER 11 Ø 0.5–8.0 mm	47

Accessories

CONTROLS	TYPE	PAGE
	Controls for BE SK-units	51

PNEUMATIC DRILLING UNIT BE 33 SK

The BE 33 SK consists of an air motor, a gear box and a body. The design is compact as well as robust. BE 33 SK comes in a wide range of speeds, and is available for lubrication-free operation.

- STURDY AND COMPACT DESIGN
- WIDE RANGE OF RPMs
- DIRECTED EXHAUST
- CHUCK ALTERNATIVES UP TO Ø20 MM
- IS AVAILABLE IN COUNTER CLOCKWISE ROTATION



Guidelines for choice of unit		[Ø, mm]											
DRILLING UNIT	CAPACITY IN STEEL				CAPACITY IN ALUMINIUM/BRASS				CAPACITY IN WOOD/PLASTICS				
	No of Spindles	1	2	3	4	1	2	3	4	1	2	3	4
LOW SPEED	BE 335 SK	13	7	6	6	16	10	10	9	26	12	10	10
	BE 337 SK	13	7	6	6	16	10	10	8	22	12	10	10
	BE 3313 SK	10	7	6	5	14	10	8	8	20	12	10	10
HIGH SPEED	BE 3326 SK	9	6	5	4	12	9	8	6	16	10	10	9
	BE 3333 SK	6	5	4	3	9	7	6	6	13	10	8	8
	BE 3360 SK	4	4	3	3	7	5	5	5	10	8	6	5
	BE 33210 SK	2.5				4				5			

Performance specifications at 6.3 Bar			
Power	0.36 kW	Run-out at spindle nose (max.)	0.05 mm
Min. Center to Center Spacing		Air consumption	<0.5 Nm ³ /min
Single Spindle	50 mm	Working pressure range	6-7 Bar
Double-Spindle Head	11 mm	Sound level	70 dB(A)

DRILLING UNIT	SPEED (IDLE) [RPM]	SPEED (AT MAX OUTPUT) [RPM]	TORQUE (AT MAX OUTPUT) [NM]
LOW SPEED	BE 335 SK	500	250
	BE 337 SK	700	350
	BE 3313 SK	1 300	650
HIGH SPEED	BE 3326 SK	2 600	1 300
	BE 3333 SK	3 300	1 650
	BE 3360 SK	6 000	3 000
	BE 33210 SK	21 000	10 500

Dimensions [mm]

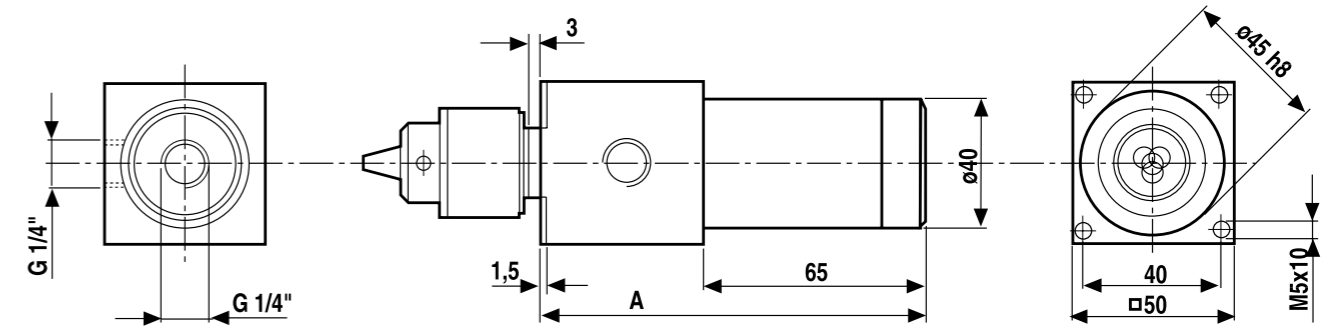

You can download 2D CAD-drawings and 3D CAD-models on www.e2systems.com.

DRILLING UNIT	A [MM]	WEIGHT [KG]
BE 335 SK	149	2.0
BE 337 SK		
BE 3313 SK		
BE 3326 SK	115	1.4
BE 3333 SK		
BE 3360 SK		
BE 33210 SK		

Necessary components

CHUCKS	TYPE	PAGE
	Key chucks Ø 0.8-10.0 mm (Standard chuck)	47
	Collet Chucks ER11 Ø 1.0-7.0 mm ER20 Ø 1.0-13.0 mm ER32 Ø 2.0-20.0 mm	47
COLLETS	TYPE	PAGE
	ER11 Ø 1.0-7.0 mm ER20 Ø 1.0-13.0 mm ER32 Ø 2.0-20.0 mm	47

Accessories

MULTI-SPINDLE HEADS	TYPE	PAGE
	Adjustable heads VH04, VH06, VH08	38
CONTROLS	TYPE	PAGE
	Controls for BE SK-units	51

AIR OPERATED DRILLING UNIT BE(S) 21

The BE 21 is an air operated drilling unit with feed. The design of the BE 21 makes it very suitable for drilling blind holes, reaming etc. We also offer this unit in a Stainless version, the BES 21, ideal for operation in environments where water or other corrosive fluids are present.

- EXTREMELY COMPACT (OUTER Ø 45 MM)
- POSITIVE STOP GUARANTEES HIGH DEGREE OF ACCURACY
- LOW AIR CONSUMPTION
- LOW NOISE LEVEL
- AVAILABLE IN STAINLESS DESIGN FOR CORROSIVE ENVIRONMENTS



Guidelines for choice of unit [Ø, mm]

DRILLING UNIT	CAPACITY IN STEEL	CAPACITY IN ALUMINIUM/BRASS	CAPACITY IN WOOD/PLASTICS
BE(S) 215	6	11	16
BE(S) 218	6	11	16
BE(S) 2111	6	10	14
BE(S) 2122	5	9	12
BE(S) 2136	4	7	10
BE(S) 2149	3	6	8
BE(S) 21220	2	3	4

Performance specifications at 6.3 Bar

Thrust (max.)	665 N	Min. CC Spindle Spacing	45 mm	Working pressure range	6-7 Bar
Power	0.25 kW	Run-out at spindle nose (max.)	0.05 mm	Air consumption	<0.3 Nm ³ /min
Stroke (max.)	50 mm	Depth accuracy +/-	0.01 mm	Sound level	70 dB(A)

DRILLING UNIT	SPEED (IDLE) [RPM]	SPEED (AT MAX OUTPUT) [RPM]	TORQUE (AT MAX OUTPUT) [NM]
BE(S) 215	500	250	9.9
BE(S) 218	800	400	6.0
BE(S) 2111	1 100	550	4.3
BE(S) 2122	2 200	1 100	2.4
BE(S) 2136	3 600	1 800	1.5
BE(S) 2149	4 900	2 450	1.1
BE(S) 21220	15 000	7 500	0.25

Dimensions [mm]

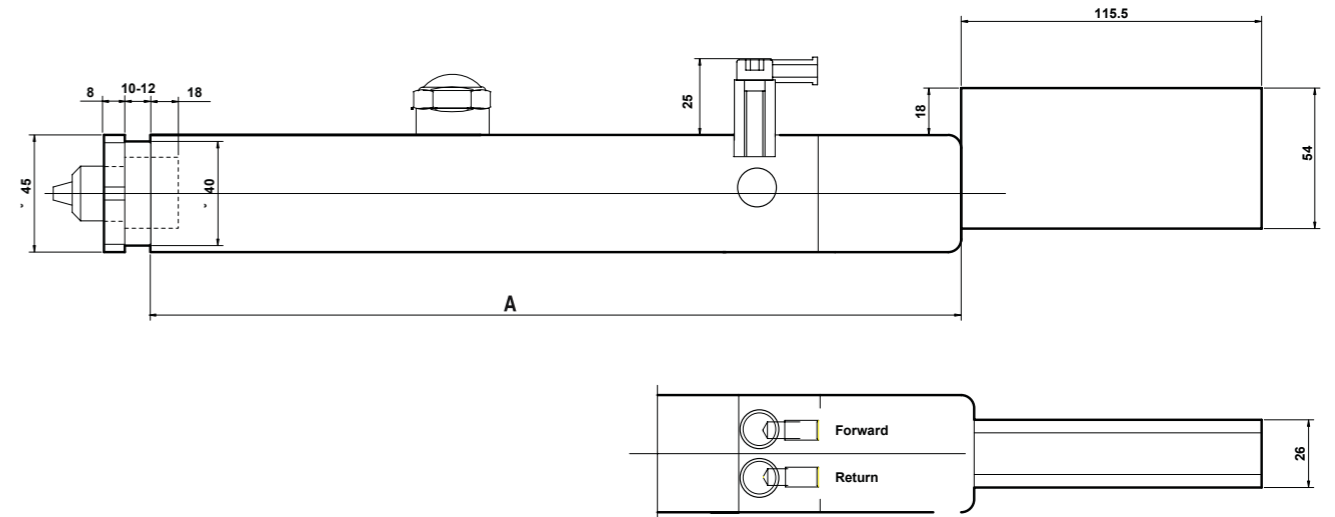

You can download 2D CAD-drawings and 3D CAD-models on www.e2systems.com.

DRILLING UNIT	A [MM]	WEIGHT [KG]
BE 215		
BE 218	312	3.3
BE 2111		
BE 2122		
BE 2136	282	3.1
BE 2149		
BE 21220		
BES 215		
BES 218	312	3.0
BES 2111		
BES 2122		
BES 2136	282	2.8
BES 2149		
BES 21220		

Necessary components

CHUCKS	TYPE	PAGE
	Key chucks Ø 0.5-6.5 mm (Standard chuck) Ø 0.8-10.0 mm	47
	Collet Chucks ER11 Ø 1.0-7.0 mm ER20 Ø 1.0-13.0 mm ER32 Ø 2.0-20.0 mm	47
COLLETS	TYPE	PAGE
	ER11 Ø 1.0-7.0 mm ER20 Ø 1.0-13.0 mm ER32 Ø 2.0-20.0 mm	47

Accessories

LIMIT SWITCHES	TYPE	PAGE
	Electric Pneumatic	51
CONTROLS	TYPE	PAGE
	Controls for BE 21-units Pneumatic Electric	51

AIR HYDRAULIC DRILLING UNIT BE(F) 22

The basic design of the BE(F) 22 consists of a vane motor powered by compressed air, a pneumatic cylinder, and a closed hydraulic system. The total stroke length can be variably subdivided into rapid advance and working feed across the whole range. The throttle/check valve in the hydraulic system permits exact setting of the feed rate and high speed return.

- EXTREMELY COMPACT DESIGN
- BUILT-IN HYDRAULICS FOR CONTROLLED WORKING FEED
- ADJUSTMENT OF DRILLING DEPTH WITH POSITIVE STOP GUARANTEES A HIGH DEGREE OF ACCURACY
- LOW NOISE LEVEL
- MINIMAL AIR CONSUMPTION

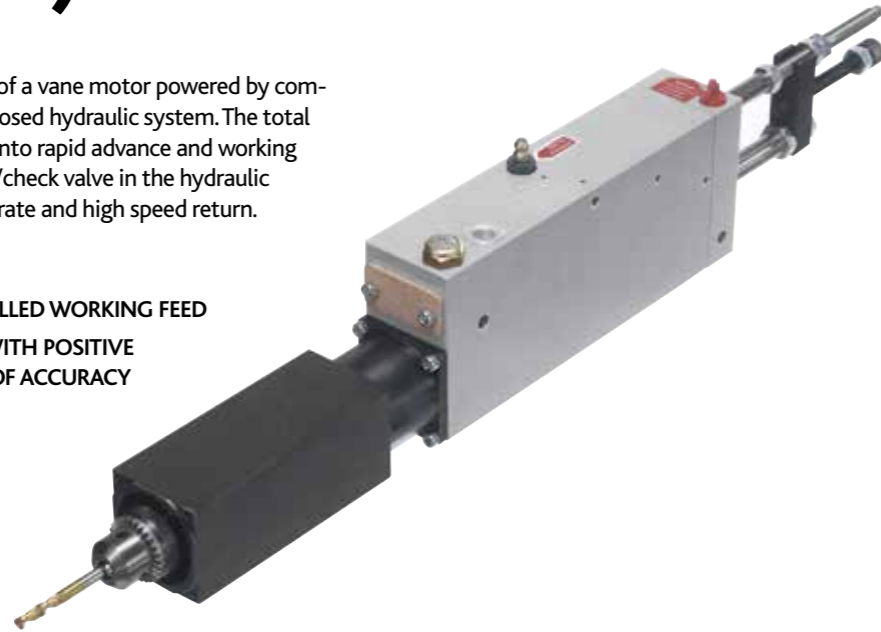

Guidelines for choice of unit													[Ø, mm]
DRILLING UNIT	CAPACITY IN STEEL				CAPACITY IN ALUMINIUM/BRASS				CAPACITY IN WOOD/PLASTICS				
	No of Spindles	1	2	3	4	1	2	3	4	1	2	3	
BE(F) 225	6	5	2.5	1.5	11	8	6	4	16	11	9	7	
BE(F) 228	6	5	2.5	1.5	11	8	6	4	16	11	9	7	
BE(F) 2211	6	4	2.5	1.5	10	8	6	4	14	11	9	7	
BE(F) 2222	5	3	2	1.5	9	7	5	4	12	9	8	6	
BE(F) 2236	4	2.5	1.5	1	7	6	4	3	10	8	7	5	
BE(F) 2249	3	1.5	1.5	1	6	4	3	2.5	8	6	6	4	
BE(F) 22150	2				3				4				
BE 22220	2				3				4				

Performance specifications at 6.3 Bar			
Thrust (max.)	600 N	Min. Center to Center Spacing	>0.01 m/min
Power	0.25 kW	Single Spindle	45 mm
Stroke (max.)		Double-Spindle Head	11 mm
BE 100% controlled	30 mm	Run-out at spindle nose (max.)	0.03 mm
BEF total	60 mm	Depth accuracy +/-	0.01 mm
of which is controlled	45 mm	Rapid advance rate	10 m/min

DRILLING UNIT	SPEED [IDLE] [RPM]	SPEED [AT MAX OUTPUT] [RPM]	TORQUE [AT MAX OUTPUT] [NM]
BE (F) 225	500	250	9.9
BE (F) 228	800	400	6.0
BE (F) 2211	1 100	550	4.3
BE (F) 2222	2 200	1 100	2.4
BE (F) 2236	3 600	1 800	1.5
BE (F) 2249	4 900	2 450	1.1
BE (F) 22150	15 000	7 500	0.25
BE 22220	22 000	11 000	0.25

Dimensions

[mm]

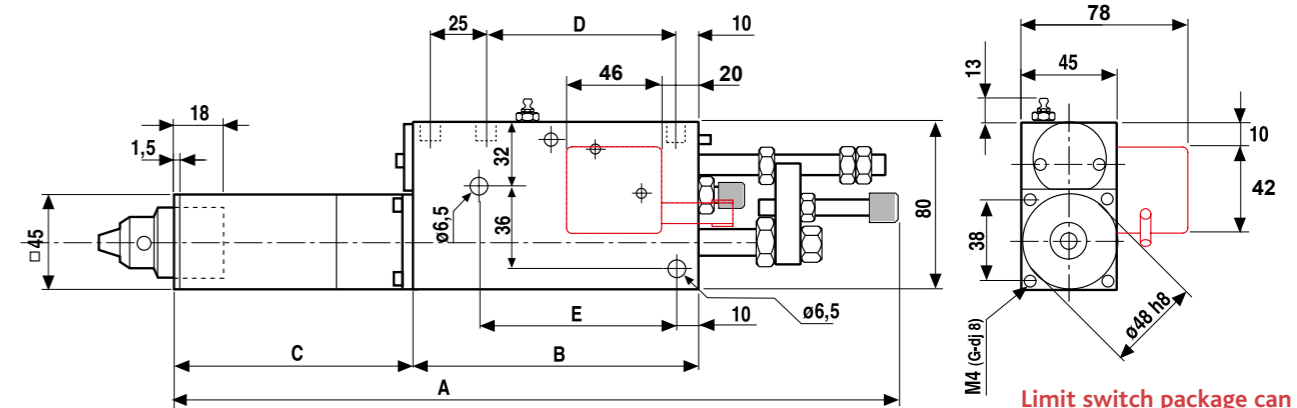

You can download 2D CAD-drawings and 3D CAD-models on www.e2systems.com.

DRILLING UNIT	A [MM]	B [MM]	C [MM]	D [MM]	E [MM]	WEIGHT [KG]
BE 225	384	140	147	94.5	107	5.1
BEF 225	519	200	177	154.5	167	7.1
BE 228	384	140	147	94.5	107	5.1
BEF 228	519	200	177	154.5	167	7.1
BE 2211	384	140	147	94.5	107	5.1
BEF 2211	519	200	177	154.5	167	7.1
BE 2222	353	140	116	94.5	107	4.7
BEF 2222	488	200	146	154.5	167	6.7
BE 2236	353	140	116	94.5	107	4.7
BEF 2236	488	200	146	154.5	167	6.7
BE 2249	353	140	116	94.5	107	4.7
BEF 2249	488	200	146	154.5	167	6.7
BE 22150/22220	353	140	116	94.5	107	4.7
BEF 22150	488	200	146	154.5	167	6.7

Necessary components

CHUCKS	TYPE	PAGE
	Key chucks Ø 0.5–6.5 mm (Standard chuck) Ø 0.8–10.0 mm	47
	Collet Chucks ER11 Ø 1.0-7.0 mm ER20 Ø 1.0-13.0 mm ER32 Ø 2.0-20.0 mm	47
COLLETS	TYPE	PAGE
	ER11 Ø 1.0-7.0 mm ER20 Ø 1.0-13.0 mm ER32 Ø 2.0-20.0 mm	47
LIMIT SWITCHES	TYPE	PAGE
	Electric Pneumatic	51

Accessories

MULTI-SPINDLE HEADS	TYPE	PAGE
	Adjustable heads VH04, VH06	38
CONTROLS	TYPE	PAGE
	Controls for BE 22-units Electric Pneumatic	51
MOUNTINGS	TYPE	PAGE
	Mountings for the BE(FP) 22	

AIR HYDRAULIC PRECISION DRILLING UNIT BE(F)P 22

The basic design of the BE(F)P 22 consists of a vane motor powered by compressed air, a pneumatic cylinder, and a closed hydraulic system. The BE(F)P 22 has a precision chuck for an extra high level of precision. Thanks to precision, separate and double ball bearings run-out amounts to a maximum of 0.01 mm. The total stroke length can be variably subdivided into rapid advance and working feed across the whole range. The throttle/check valve in the hydraulic system permits exact setting of the feed rate and high speed return.

- PRECISION DESIGN WITH A MAX RUN-OUT AT SPINDLE NOSE OF 0.01 MM
- EXTREMELY COMPACT DESIGN
- BUILT-IN HYDRAULICS FOR CONTROLLED WORKING FEED
- ADJUSTMENT OF DRILLING DEPTH WITH POSITIVE STOP GUARANTEES A HIGH DEGREE OF ACCURACY
- LOW NOISE LEVEL
- MINIMAL AIR CONSUMPTION

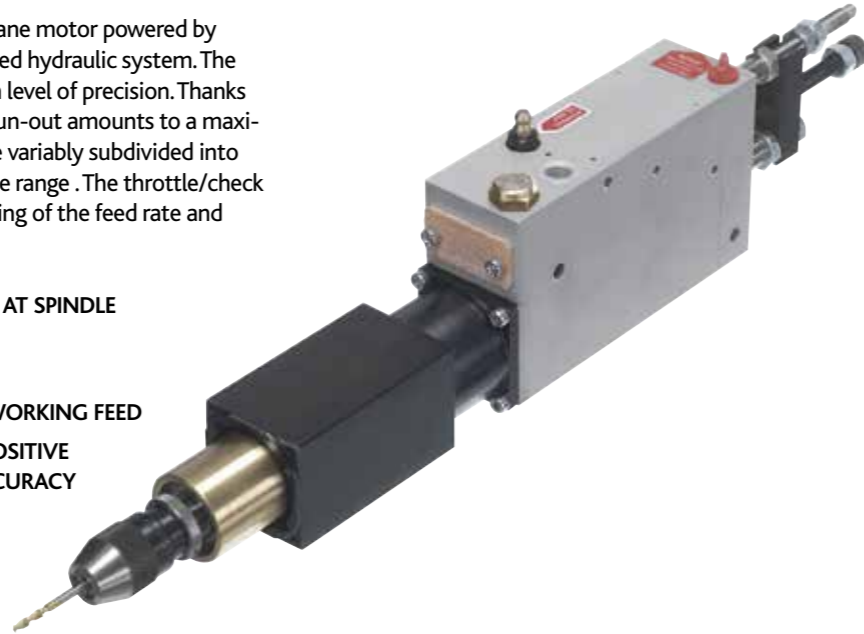

Guidelines for choice of unit [Ø, mm]			
DRILLING UNIT	CAPACITY IN STEEL	CAPACITY IN ALUMINIUM/BRASS	CAPACITY IN WOOD/PLASTICS
BE(F)P 2222	5	9	12
BE(F)P 2236	4	7	10
BE(F)P 2249	3	6	8
BEFP 22150	2	3	4
BEP 22220	2	3	4

Performance specifications at 6.3 Bar					
Thrust (max.)	600 N	Min. CC Spindle Spacing	45 mm	Air consumption	<0.3 Nm ³ /min
Power	0.25 kW	Run-out at spindle nose (max.)	0.01 mm	Sound level	70 dB(A)
Stroke (max.)		Depth accuracy +/-	0.01 mm		
BEP 100% controlled	30 mm	Rapid advance rate	10 m/min		
BEFP total	60 mm	Controlled feed rate	>0.01 m/min		
of which is controlled	45 mm	Working pressure range	6-7 Bar		

DRILLING UNIT	SPEED (IDLE) [RPM]	SPEED (AT MAX OUTPUT) [RPM]	TORQUE (AT MAX OUTPUT) [NM]
BEP 2222	2 200	1 100	2.4
BEFP 2222	2 200	1 100	2.4
BEP 2236	3 600	1 800	1.5
BEFP 2236	3 600	1 800	1.5
BEP 2249	4 900	2 450	1.1
BEFP 2249	4 900	2 450	1.1
BEFP 22150	15 000	7 500	0.25
BEP 22220	22 000	11 000	0.25

Dimensions [mm]

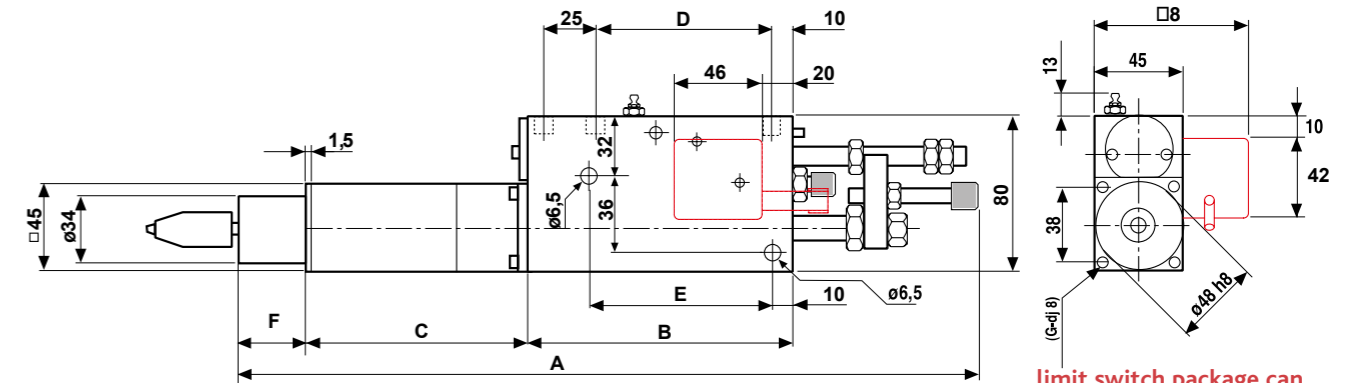

You can download 2D CAD-drawings and 3D CAD-models on www.e2systems.com.

limit switch package can be mounted on either side.

DRILLING UNIT	A [MM]	B [MM]	C [MM]	D [MM]	E [MM]	F [MM]	WEIGHT [KG]
BEP 2222	380	140	116	94.5	107	32	4.7
BEFP 2222	485	200	146	154.5	167	2	6.7
BEP 2236	380	140	116	94.5	107	32	4.7
BEFP 2236	485	200	146	154.5	167	2	6.7
BEP 2249	380	140	116	94.5	107	32	4.7
BEFP 2249	485	200	146	154.5	167	2	6.7
BEFP 22150	485	200	146	154.5	167	2	6.7
BEP 22220	380	140	116	94.5	107	32	4.7

Necessary components

CHUCKS	TYPE	PAGE
	Precision chucks Ø 0-3.0 mm Ø 0-5.0 mm (Standard chuck) Ø 0-8.0 mm	47
COLLETS	TYPE	PAGE
	Precision Collet Chuck ER 11 Ø 0.5-8.0 mm	47
COLLETS	TYPE	PAGE
	ER 11 Ø 0.5-8.0 mm	47
LIMIT SWITCHES	TYPE	PAGE
	Electric Pneumatic	51

Accessories

CONTROLS	TYPE	PAGE
	Controls for BE 22-units Electric Pneumatic	51
MOUNTINGS	TYPE	PAGE
	Mountings for the BE(F)P22	

AIR HYDRAULIC DRILLING UNIT BE 33

The basic design of the BE 33 consists of a vane motor powered by compressed air, a pneumatic cylinder, and a closed hydraulic system. The total stroke length can be variably subdivided into rapid advance and working feed over the whole range. The throttle/check valve in the hydraulic system permits exact setting of the feed rate and high speed return.

- VERY COMPACT DESIGN
- BUILT-IN HYDRAULICS FOR CONTROLLED WORKING FEED
- ADJUSTMENT OF DRILLING DEPTH WITH POSITIVE STOP GUARANTEES A HIGH DEGREE OF ACCURACY
- EXTRA STABLE SPINDLE BEARINGS
- LOW NOISE LEVEL
- MINIMAL AIR CONSUMPTION



Dimensions [mm]

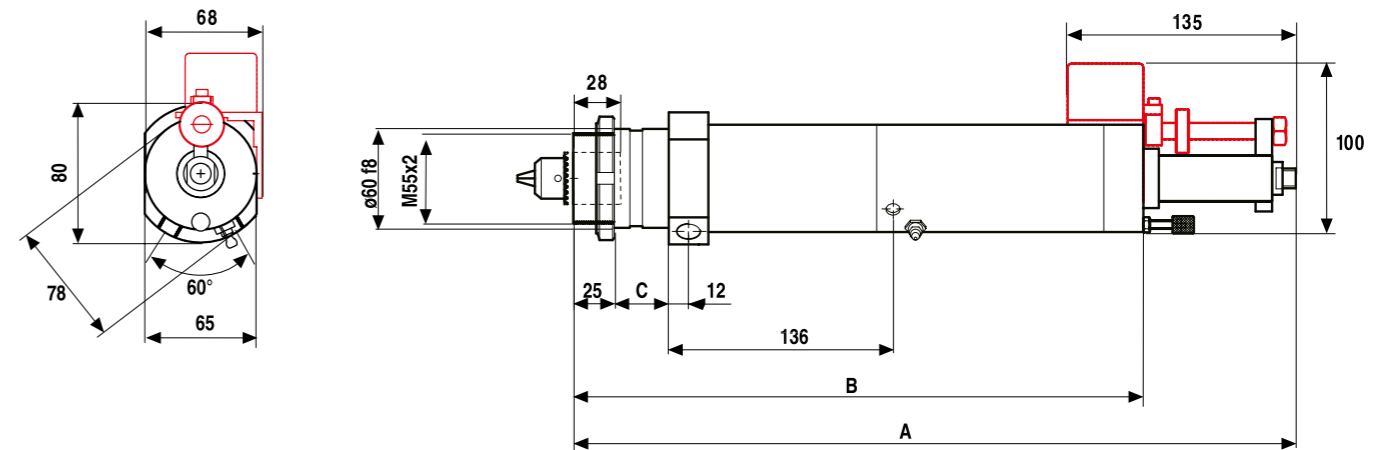

You can download 2D CAD-drawings and 3D CAD-models on www.e2systems.com.

[limit switch package.](#)

DRILLING UNIT	A [MM]	B [MM]	C [MM]	WEIGHT [KG]
BE 335	472	380	67	7.1
337				
BE 3313				
BE 3326	438	346	33	6.6
BE 3333				
BE 3360				
BE 33210				

Guidelines for choice of unit [Ø, mm]

DRILLING UNIT	CAPACITY IN STEEL				CAPACITY IN ALUMINIUM/BRASS				CAPACITY IN WOOD/PLASTICS				
	No of Spindles	1	2	3	4	1	2	3	4	1	2	3	4
BE 335	10	6	4	3	14	10	8	5	20	12	10	9	
BE 337	10	6	4	3	14	10	8	5	20	12	10	9	
BE 3313	9	6	4	2.5	12	10	8	5	16	12	10	9	
BE 3326	7	4	3	2	10	8	6	4	13	10	9	8	
BE 3333	6	3	3	2	9	7	5	4	13	10	8	7	
BE 3360	3	2	2	1	7	5	4	3	8	8	6	5	
BE 33210	2.5				4				5				

Performance specifications at 6.3 Bar

Thrust	see below	Run-out at spindle nose (max.)	0.05 mm	Air consumption	<0.5 Nm ³ /min
Power	0.36 kW	Depth accuracy +/-	0.01 mm	Sound level	70 dB(A)
Stroke (max. 100% controlled)	50 mm	Rapid advance rate	10 m/min		
Min. Center to Center Spacing		Controlled feed rate	>0.01 m/min		
Single Spindle	65 mm	Working pressure range	6-7 Bar		
Double-Spindle Head	11 mm				

DRILLING UNIT	SPEED (IDLE) [RPM]	SPEED (AT MAX OUTPUT) [RPM]	TORQUE (AT MAX OUTPUT) [NM]	THRUST [N]
BE 335	500	250	12.6	1 000
BE 337	700	350	10.4	1 000
BE 3313	1 300	650	5.7	1 000
BE 3326	2 600	1 300	2.9	800
BE 3333	3 300	1 650	2.3	800
BE 3360	6 000	3 000	1.3	800
BE 33210	21 000	10 500	0.37	800

Necessary components

CHUCKS	TYPE	PAGE
	Key chucks Ø 0.5-6.5 mm Ø 0.8-10.0 mm (Standard chuck)	47
	Collet Chucks ER11 Ø 1.0-7.0 mm ER20 Ø 1.0-13.0 mm ER32 Ø 2.0-20.0 mm	47
COLLETS	TYPE	PAGE
	ER11 Ø 1.0-7.0 mm ER20 Ø 1.0-13.0 mm ER32 Ø 2.0-20.0 mm	47
LIMIT SWITCHES	TYPE	PAGE
	Electric Pneumatic	51

Accessories

MULTI-SPINDLE HEADS	TYPE	PAGE
	Adjustable heads VH04, VH06, VH08	38
CONTROLS	TYPE	PAGE
	Controls for BE 33-units Electric Pneumatic	51
MOUNTINGS	TYPE	PAGE
	Mountings for the BE33	-

ELECTRO PNEUMATIC DRILLING UNIT BE 48

The BE 48-series is a flexible electro-pneumatic series of units in a modular design. The electric motor powers the spindle, while the feed is pneumatic. Hydraulic feed control makes it possible to include functions such as multi-wall drilling, rapid advance and automatic chip removal. The series is available with JT2 taper or integrated ER32 chuck as well as with multi-spindle heads.

- COMPACT YET FLEXIBLE DESIGN
- MODULAR HYDRAULIC FEED CONTROL FOR THE WHOLE STROKE
- SMART DEPTH CONTROL
- LINEAR TRANSDUCER FOR TOTAL CONTROL OF THE COMPLETE CYCLE (OPTIONAL)



Guidlines for choice of unit [Ø, mm]												
DRILLING UNIT	CAPACITY IN STEEL				CAPACITY IN ALUMINIUM/BRASS				CAPACITY IN WOOD/PLASTICS			
No of Spindles	1	2	3	4	1	2	3	4	1	2	3	4
BE481	10	6	4	3	15	12	8	6	21	16	11	8
BE484	12	8	5	4	20	16	11	9	26	19	15	12
BE487	16	10	7	5	25	20	15	12	35	25	20	15

Performance specifications at 6.3 Bar					
Thrust (max.)		Min. Center to Center Spacing		Rapid advance rate (max.)	10 m/min
BE481	1 650 N	Single Spindle	90 mm	Controlled feed rate	>0.04 m/min
BE484	2 000 N	Double-Spindle Head	12 mm	Air consumption	2.8 l/100mm
BE487	2 000 N	Run-out at spindle nose (max.)	0.02 mm	Sound level	<85 dB(A)
Stroke (max. 100% controlled)	100 mm	Depth accuracy +/-	0.01 mm		

Motor and Transmission specifications			
No of Poles	DRILLING UNIT/MOTOR AT V380-420(Y)/220-240(Δ)50HZ [kW]		
	BE481	BE484	BE487
2	0.55	1.1	2.2
4	0.37	0.75	1.5
6	0.25	0.55	1.1
8			0.55

• Motor specifications shown in the tables are valid for 380–420V(Y) /220–240V(Δ) (±5%), 50 Hz. These motors can also be used at 440–480 V(Y) (±5%), 60 Hz. If so the rpm will increase by ~20% and the power by ~15% relative to the data for 50Hz. E2 also offers motors for other voltages and frequencies. Please state voltage and frequency when requesting a quote or ordering.

• The torque at the spindle for a specific rpm is calculated as:
 $M = (P_{[kW]} \times 9500) / \text{rpm}$

No of Poles	SPINDEL RPM AT GEAR RATIO AND 50HZ														
	2.5:1	2.1:1	1.8:1	1.6:1	1.4:1	1.2:1	1:1	1:1.2	1:1.4	1:1.6	1:1.8	1:2.1	1:2.5	1:3.1	
2	1130*	1350	1580	1750	2090	2420	2820	3290	3810	4550	5040	5880	7170*	8600*	
4	560*	670	780	860	1030	1190	1390	1620	1880	2240	2480	2900	3530*	4240*	
6	360*	440	510	560	670	780	910	1060	1230	1470	1630	1900	2310*	2780*	
8	270*	330	380	420	500	580	680	790	920	1100	1210	1420	1730*	2070*	

*Not available for BE487

Dimensions

[mm]

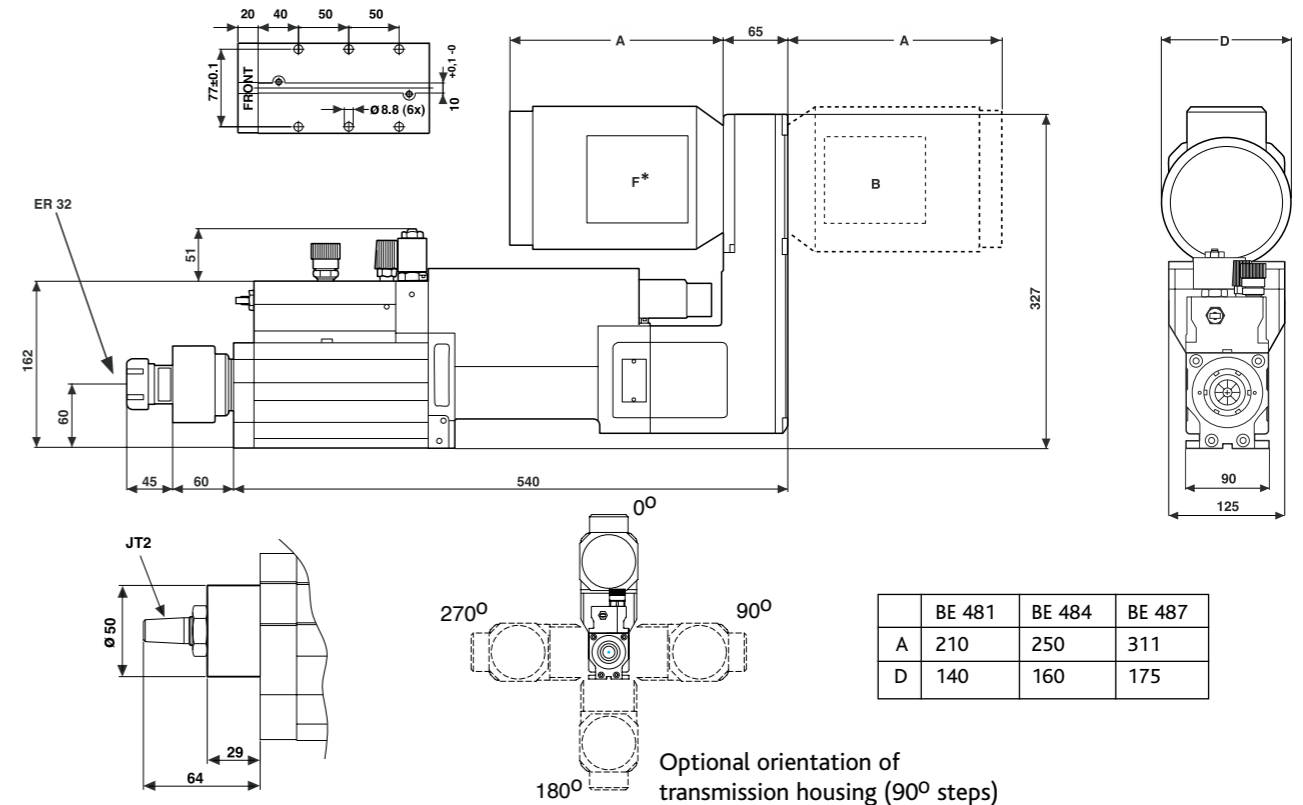

*Front mount is not possible at BE487 with linear transducer

You can download 2D CAD-drawings and 3D CAD-models on www.e2systems.com.

WEIGHT 29-40 KG

Necessary components

CHUCKS	TYPE	PAGE
	Drill Chucks for JT2 Ø 1.0–10.0 mm Ø 3.0–16.0 mm	47
	Integrated ER32 Collet Chuck Ø 2.0 –20.0 mm	47
COLLETS	TYPE	PAGE
	ER32, Ø 2.0–20.0 mm	47
LIMIT SWITCHES	TYPE	PAGE
	Electric switches Pneumatic switches Inductive switches or Linear Transducer	51

Accessories

MULTI-SPINDLE HEADS	TYPE	PAGE
	Adjustable heads VH04- VH06, VH08, VH10-	38
CONTROLS	TYPE	PAGE
	Controls for BE 48-units with Electric switches Pneumatic switches Inductive switches or Linear Transducer	51

On www.e2systems.com you can find more information as well as the same information as above in imperial units.

When requesting a quote or ordering, please state: **Model, Chuck (collet size), Limit Switches, Spindle rpm, Motor Power and Front or Backward Motor orientation.**

ELECTRO HYDRAULIC DRILLING UNIT BE 55

BE 55 is a powerful yet compact electro-hydraulic series of units. The electric motor runs the spindle while the feed is hydraulically powered and controlled. The hydraulic feed control together with position switches makes it possible to include functions such as multi-wall drilling, rapid advance and automatic chip removal. The units are available in two different taper options as well as with multi-spindle heads.

- COMPACT YET POWERFUL DESIGN
- INTEGRATED HYDRAULIC SYSTEM
- LONG STROKE – 120 MM
- IDEAL FOR FLOW DRILLING
- HIGH PRECISION
- LOW NOISE LEVEL

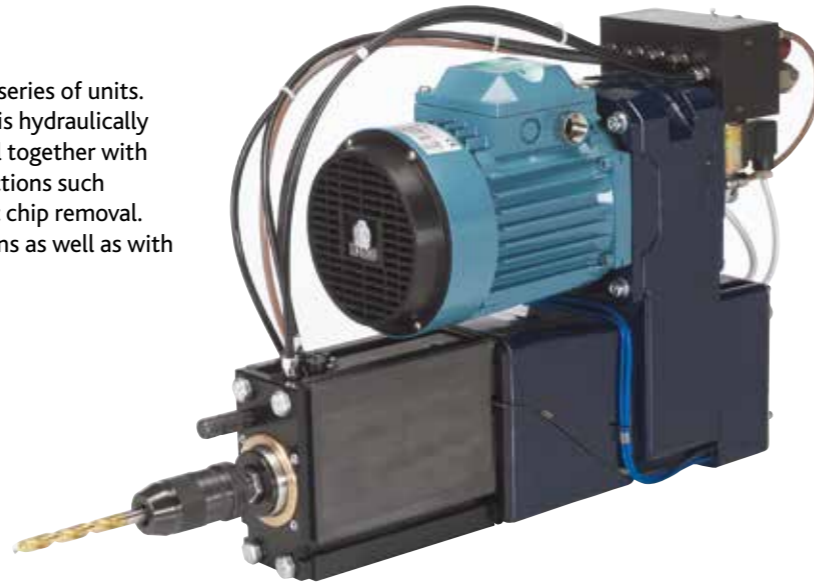

Guidlines for choice of unit [Ø, mm]												
DRILLING UNIT	CAPACITY IN STEEL				CAPACITY IN ALUMINIUM/BRASS				CAPACITY IN WOOD/PLASTICS			
	No of Spindles	1	2	3	4	1	2	3	4	1	2	3
BE55	25	19	14	11	35	27	23	18	40	35	26	23

Performance specifications				
Thrust (max.)	6 000 N	Run-out at spindle nose (max.)	JT2	0.02 mm
Stroke (max. 100% controlled)	120 mm		MT2	0.03 mm
Min. Center to Center Spacing		Depth accuracy +/-		0.01 mm
Single Spindle	140 mm	Rapid advance rate (max.)		6 m/min
Double-Spindle Head	17 mm			
		Controlled feed rate		0.04–0.65 m/min
		Sound level		<80 dB(A)

Motor and Transmission specifications	
No of Poles	DRILLING UNIT/MOTOR AT V380-420(Y)/220-240(Δ)50HZ [kW] BE55
2	2.2
4	1.5
6	1.1
8	0.55

• Motor specifications shown in the tables are valid for 380–420V(Y) / 220–240V(Δ) (±5%), 50 Hz. These motors can also be used at 440–480V(Y) (±5%), 60 Hz. If so the rpm will increase by ~20% and the power by ~15% relative to the data for 50Hz. E2 also offers motors for other voltages and frequencies. Please state voltage and frequency when requesting a quote or ordering.

• The torque at the spindle for a specific rpm is calculated as:
 $M = (P_{[kW]} \times 9500) / \text{rpm}$

No of Poles	SPINDEL RPM AT GEAR RATIO AND 50HZ								
	2.8:1	2.2:1	1.7:1	1.3:1	1:1	1:1.3	1:1.7	1:2.2	1:2.8
2	1020	1300	1690	2170	2820	3670	4700	6130	7780
4	500	640	830	1070	1390	1810	2320	3020	3830
6	330	420	550	700	910	1180	1520	1980	2510
8	250	310	410	520	680	880	1130	1480	1880

Dimensions [mm]

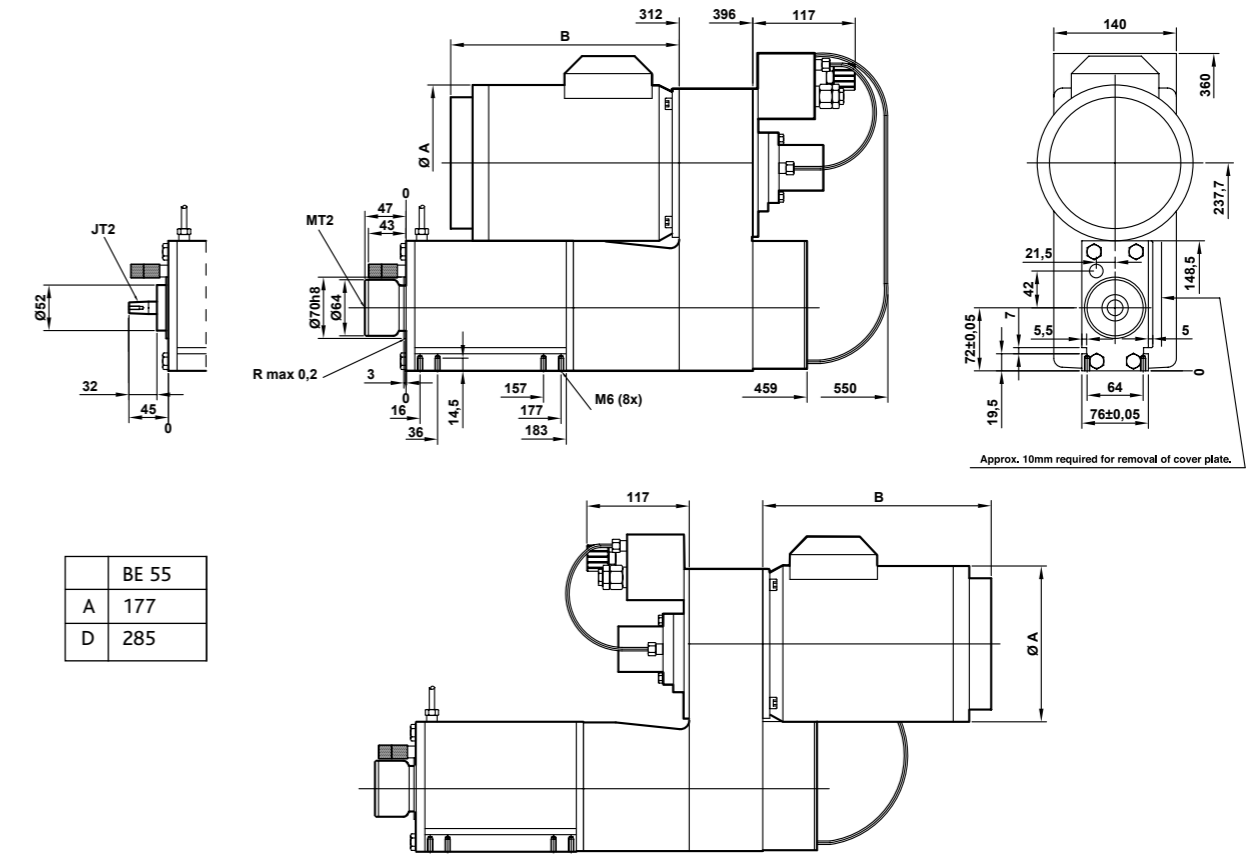

	BE 55
A	177
D	285

You can download 2D CAD-drawings and 3D CAD-models on www.e2systems.com.

WEIGHT 35-46KG

Necessary components		
CHUCKS	TYPE	PAGE
	Drill Chucks for JT2: Ø 1.0–10.0 mm for MT2: Ø 3.0–16.0 mm	47
	Collet Chuck for JT2 ER 40 Ø 3.0–30.0 mm	47
	Collet Chuck for MT2 ER40 Ø2,0-30 mm	
COLLETS	TYPE	PAGE
	Collets ER 40 Ø 3.0–30.0 mm	47

Accessories		
MULTI-SPINDLE HEADS	TYPE	PAGE
	Adjustable heads VH06, VH08, VH10, VH13, VH18	38
CONTROLS	TYPE	PAGE
	Controls for BE(G)55-units	51

On www.e2systems.com you can find more information as well as the same information as above in imperial units. When requesting a quote or ordering, please state: **Model, Chuck (collet size), Control system, Spindle rpm, Motor Power and Front or Backward Motor orientation.**

TAPPING UNITS

UNIT	PAGE	DRIVE	FEED	TAPPING CAPACITY		
				STEEL	ALUMINIUM/ BRASS	PLASTICS
LS22	28	Pneumatic 5-vane Motor	Lead screw	M8	M12	M12
BEG48	30	Electric Air Hydraulic	Controlled	M12	M20	M30
BEG55	32	Electric Hydraulic	Controlled	M16	M24	M30

TAPPING UNITS

E2 tapping units can be found throughout the world wherever a high level of productivity and precision is a priority. A long service life with excellent reliability and continued precision makes E2's tapping units a good investment.

E2 tapping units range from the most compact pneumatic units on the market to powerful electrically-operated units. Our lead screw units ensure a perfect tapping process with no risk of damaging the tap. These characteristics also apply to units equipped with multi-spindle heads.

Each tapping unit's details includes all the necessary information for selecting a suitable model based on the requirements set by your tapping application and the cutting data specified by your tap supplier. In addition to performance specifications, you will also find information on dimensions, necessary components and accessories.

To provide a quick summary, there are also guidelines for the capacities of the various models, based on conventional thread taps in the most common materials. For fluteless taps, as a rule of thumb, 50-100% greater torque and speed is required.

PNEUMATIC LEAD SCREW TAPPING UNIT LS 22

The LS 22 consists of a vane motor powered by compressed air, a planetary gearbox, lead screw, nut and a follower with cams to activate built-in switches. The design of the LS 22 is compact yet highly functional. The lead screw ensures high repeatability for threading operations.

- EXTREMELY COMPACT DESIGN
- SEALED LEAD SCREW
- LOW NOISE LEVEL
- SMART DEPTH CONTROL
- AVAILABLE IN ALL THREAD TYPES AS WELL AS LEFT HAND



Guidlines for choice of unit [M-Thread]												
TAPPING UNIT	CAPACITY IN STEEL				CAPACITY IN ALUMINIUM/BRASS				CAPACITY IN PLASTICS			
No of Spindles	1	2	3	4	1	2	3	4	1	2	3	4
LS 223	M8	M6	M6	M5	M12	M10	M8	M8	M12	M12	M10	M10
LS 225	M6	M5	M5	M4	M12	M8	M6	M6	M12	M10	M8	M8
LS 226	M6	M5	M5	M4	M10	M8	M6	M6	M10	M8	M8	M6
LS 2213	M5	M4	M4	M3	M8	M6	M5	M5	M8	M8	M6	M5
LS 2221	M4	M3	M3	M2	M6	M5	M4	M4	M8	M6	M5	M4
LS 2228					M5				M6	M5		

Performance specifications at 6.3 Bar			
Power	0.16 kW	Depth accuracy +/-	0.01 mm
Stroke (max, 100% controlled)	51 mm	Working pressure range	6-7 Bar
Min. Center to Center Spacing		Air consumption	<0.3 Nm ³ /min
Single Spindle	42 mm	Sound level	70 dB(A)
Double-Spindle Head	11 mm		

TAPPING UNIT	SPEED (IDLE) [RPM]	SPEED (AT MAX OUTPUT) [RPM]	TORQUE (AT MIN STARTING) [NM]	TORQUE (AT MAX OUTPUT) [NM]
LS 223	240	140	13.4	10.8
LS 225	400	240	8.0	6.7
LS 226	540	310	5.9	5.0
LS 2213	1 050	650	3.0	2.4
LS 2221	1 750	1 050	1.8	1.5
LS 2228	2 400	1 390	1.3	1.1

Dimensions [mm]

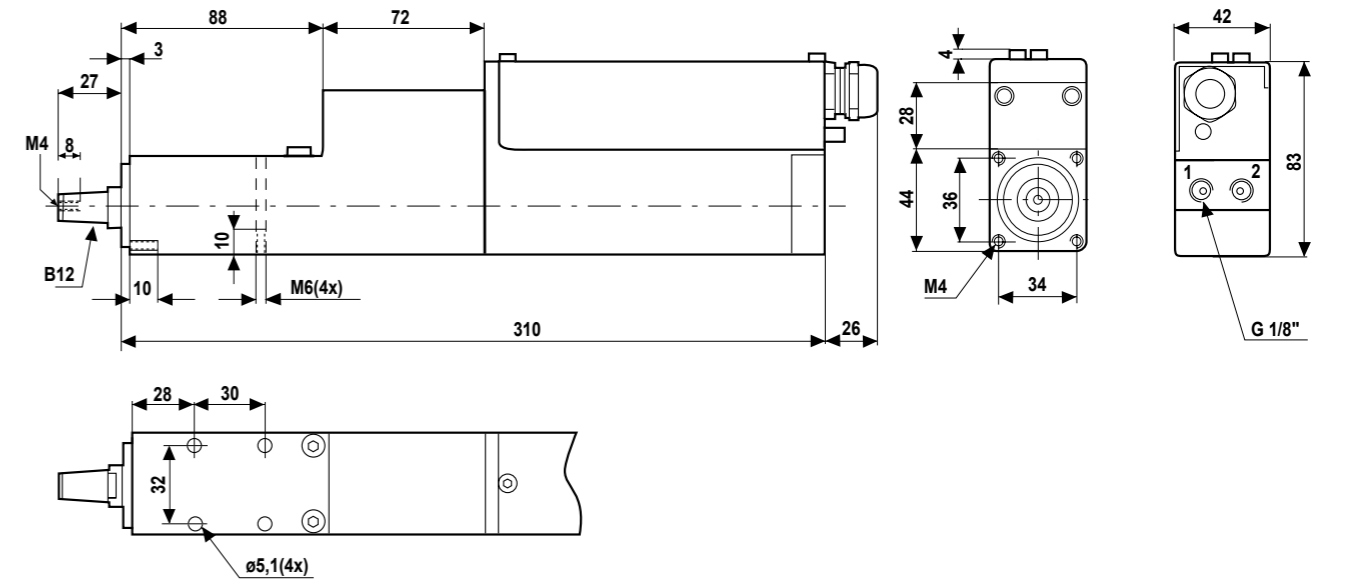

You can download 2D CAD-drawings and 3D CAD-models on www.e2systems.com.

WEIGHT 4.6 KG

Necessary components

QUICK CHANGE CHUCK	TYPE	PAGE
	C12 for B12 Metric and Inches	47
TAP HOLDER	TYPE	PAGE
	T12 for C12 (B12) Metric and Inches	47
LIMIT SWITCHES	TYPE	PAGE
	Electric Pneumatic	51

Accessories

MULTI-SPINDLE HEADS	TYPE	PAGE
	Adjustable heads VH04, MBKV 402	38
CONTROLS	TYPE	PAGE
	Controls for LS 22 units Electric Pneumatic	51
MOUNTINGS	TYPE	PAGE
	Mountings for the LS22 units.	

On www.e2systems.com you can find more information as well as the same information as above in imperial units.

When requesting a quote or ordering, please state: Model, Limit switches, Ø and □ for the tap holder, pitch, and if it is to be used in Lubrication-free operation.

ELECTRO PNEUMATIC TAPPING UNIT BEG 48

The BEG 48-series is a flexible electro-pneumatic unit in a modular design. The electric motor runs the spindle, while the feed is pneumatic. Hydraulic feed control makes it possible to use rapid advance and to adjust the feed rate in proportion to the pitch and the rpm. A tapping collect or a tapping spindle gives the unit the necessary length compensation. The series is available with JT2 taper or integrated ER32 chuck as well as with multi-spindle heads.

- COMPACT YET FLEXIBLE DESIGN
- MODULAR HYDRAULIC FEED CONTROL FOR THE WHOLE STROKE
- SMART DEPTH CONTROL
- LINEAR TRANSDUCER FOR TOTAL CONTROL OF THE COMPLETE CYCLE (OPTIONAL)

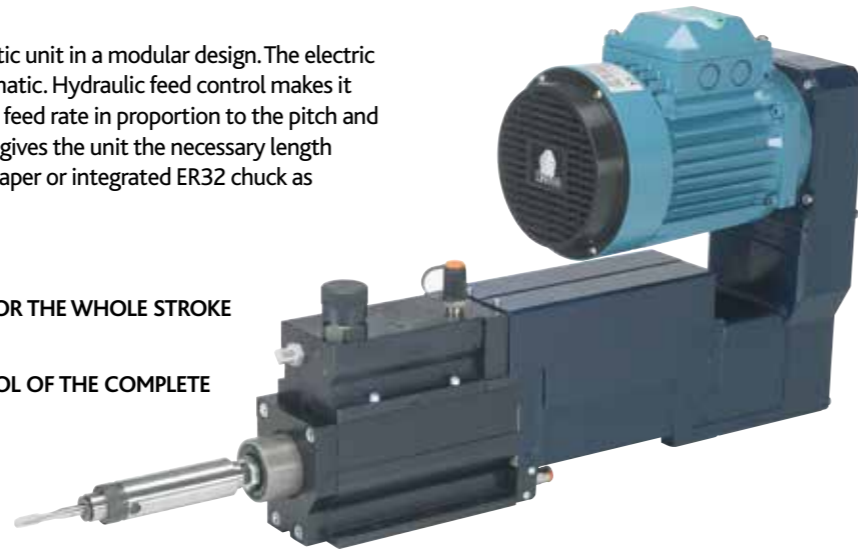

Guidlines for choice of unit [M-Thread]

TAPPING UNIT	CAPACITY IN STEEL				CAPACITY IN ALUMINIUM/BRASS				CAPACITY IN PLASTICS				
	No of Spindles	1	2	3	4	1	2	3	4	1	2	3	4
BEG 481	M6	M5	M4	M3	M10	M8	M8	M6	M6	M14	M8	M8	M8
BEG 484	M8	M6	M5	M5	M14	M10	M8	M8	M8	M16	M14	M12	M10
BEG 487	M12	M8	M6	M6	M20	M14	M12	M10	M10	M30	M20	M20	M16

Performance specifications at 6.3 Bar

Thrust (max.)	1 650–2 000 N	Depth accuracy +/-	0.01 mm
Stroke (max. 100% controlled)	100 mm	Rapid advance rate (max.)	10 m/min
Min. Center to Center Spacing		Controlled feed rate	>0.04 m/min
Single Spindle	90 mm	Air consumption	2.8 U/100mm
Double-Spindle Head	12 mm	Sound level	<85 dB(A)

Motor and Transmission specifications

No of Poles	TAPPING UNIT/MOTOR AT V380-420(Y)/220-240(Δ) 50HZ [kW]		
	BEG481	BEG484	BEG487
2	0.55	1.1	2.2
4	0.37	0.75	1.5
6	0.25	0.55	1.1
8			0.55

• Motor specifications shown in the tables are valid for 380–420V(Y) /220–240V(Δ) (±5%), 50 Hz. These motors can also be used at 440–480 V(Y) (±5%), 60 Hz. If so the rpm will increase by ~20% and the power by ~15% relative to the data for 50Hz. E2 also offers motors for other voltages and frequencies. Please state voltage and frequency when requesting a quote or ordering.

• The torque at the spindle for a specific rpm is calculated as: $M = (P_{[kW]} \times 9500) / \text{rpm}$

No of Poles	SPINDEL RPM AT GEAR RATIO AT 50HZ													
	2.5:1	2:1:1	1.8:1	1.6:1	1.4:1	1.2:1	1:1	1:1.2	1:1.4	1:1.6	1:1.8	1:2:1	1:2.5	
2	1130*	1350	1580	1750										
4	560*	670	780	860	1030	1190	1390	1620	1880					
6	360*	440	510	560	670	780	910	1060	1230	1470	1630	1900		
8	270*	330	380	420	500	580	680	790	920	1100	1210	1420	1730*	

30 *Not available for BEG487

E2 does not recommend tapping with a floating holding at higher speeds than 2000 rpm. Maximum speed is lower when tapping a deep or blind hole and/or using a large thread.

Dimensions

[mm]

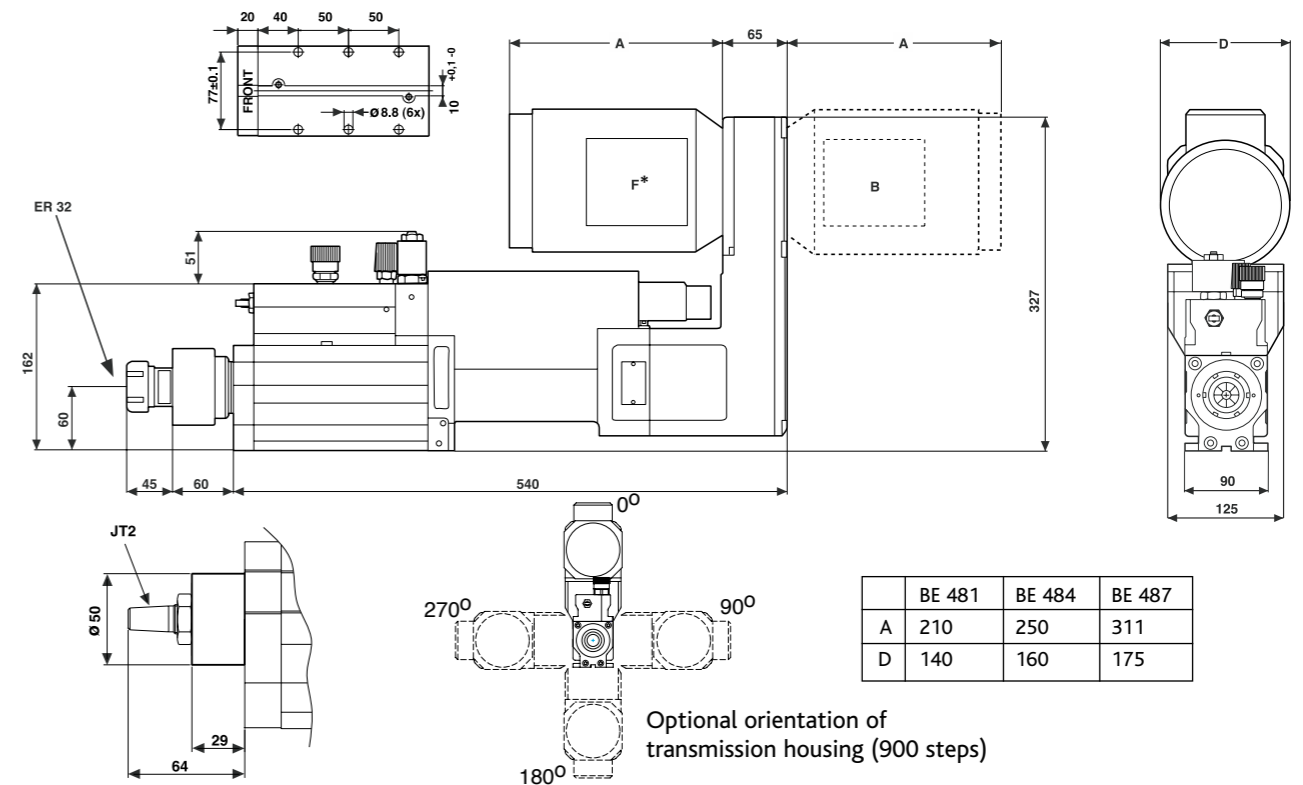

Optional orientation of transmission housing (900 steps)

*Front mount is not possible at BE487 with linear transducer

You can download 2D CAD-drawings and 3D CAD-models on www.e2systems.com.

WEIGHT 29-40 KG

Necessary components

TAPPING ATTACHMENTS	TYPE	PAGE
	Length compensation up to 10 mm	47
	Integrated ER32 chuck with length compensating collets M4-M12	
	Length compensation up to: 25 mm Tapping spindle GS12E M4-M16 (JT2) 40 mm Tapping spindle GS24E M8-M30 (ER32+B18/e16 taper shank)	47
TAP HOLDERS	TYPE	PAGE
	ER32 collets with length compensation M4-M12	47
	T12 for GS12E T24 for GS24E	47
LIMIT SWITCHES	TYPE	PAGE
	Electric switches Pneumatic switches Inductive switches or Linear Transducer	51

Accessories

MULTI-SPINDLE HEADS	TYPE	PAGE
	Adjustable heads VH04-, VH06-, VH08-, VH10-, MBK V40-,	38
CONTROLS	TYPE	PAGE
	Controls for BEG 48-units with Electric switches Pneumatic switches Inductive switches or Linear Transducer	51

On www.e2systems.com you can find more information as well as the same information as above in imperial units.

When requesting a quote or ordering, please state: **Model, Chuck (collet size), Limit Switches, Spindle rpm, Motor Power, Front or Backward Motor orientation, Float compensation required (if known) as well as Ø and □ for the tap holder.**



MILLING UNITS



PNEUMATIC MILLING UNITS BE 22 SKM AND BE 33 SKM

The BE 22/33 SKM consists of an air motor, a gear box and a robust body. The design is compact as well as robust. BE 22/33 SKM comes in a wide range of speeds, and is available for lubrication-free operation.

- STURDY AND COMPACT DESIGN
- WIDE RANGE OF RPMs
- DIRECTED EXHAUST



Guidelines for choice of unit [mm]

MILLING UNIT	TOOL	CAPACITY IN STEEL	CAPACITY IN ALUMINUM/BRASS	CAPACITY IN WOOD/PLASTIC
BE 22 SKM	Saw ø	-	100	100
	Blade gauge	-	2	4
BE 33 SKM	Saw ø	80	100	100
	Blade gauge	1.5	4	6
BE 22 SKM	End mill ø	4	6	10
	Cutting depth	2	2	4
BE 33 SKM	End mill ø	6	10	25
	Cutting depth	2	4	6

Performance specifications at 6.3 Bar

Power BE 22 SKM	0.25 kW	Air consumption BE 22 SKM <0.3 Nm ³ /min	Working pressure range	6-7 Bar
BE 33 SKM	0.36 kW	BE 33 SKM <0.5 Nm ³ /min	Sound level	70 dB(A)

MILLING UNIT	SPEED (IDLE) [RPM]	SPEED (AT MAX OUTPUT) [RPM]	TORQUE (AT MAX OUTPUT) [NM]	
LOW SPEED	BE 225 SKM	500	250	9.9
	BE 228 SKM	800	400	6.0
	BE 2211 SKM	1 100	550	4.3
HIGH SPEED	BE 2222 SKM	2 200	1 100	2.4
	BE 2236 SKM	3 600	1 800	1.5
	BE 2249 SKM	4 900	2 450	1.1
	BE 22220 SKM	22 000	11 000	0.25
LOW SPEED	BE 335 SKM	500	250	12.6
	BE 337 SKM	700	350	10.4
	BE 3313 SKM	1 300	650	5.7
	BE 3326 SKM	2 600	1 300	2.9
	BE 3333 SKM	3 300	1 650	2.3
	BE 3360 SKM	6 000	3 000	1.3
	BE 33210 SKM	21 000	10 500	0.37

Dimensions [mm]

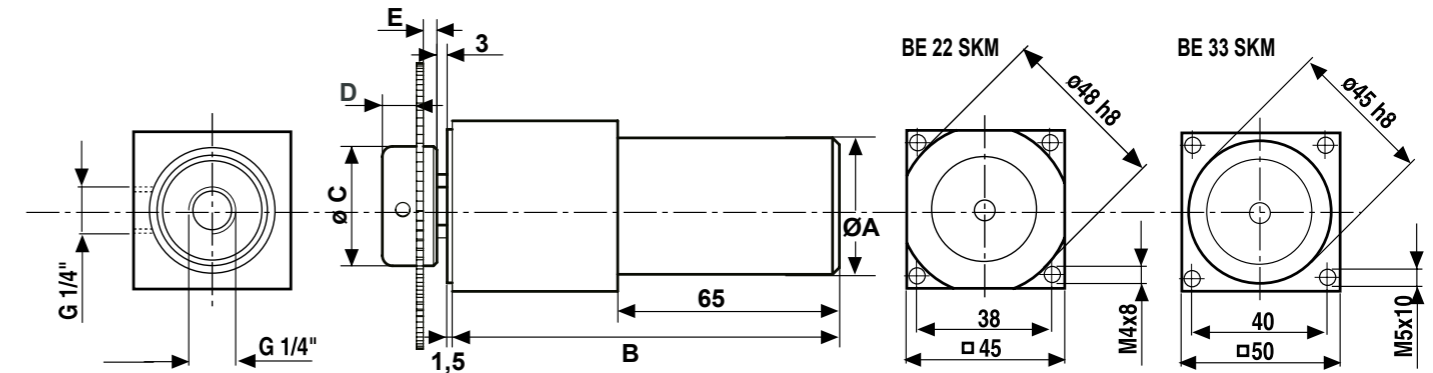

You can download 2D CAD-drawings and 3D CAD-models on www.e2systems.com.

MILLING UNIT	SPEED	øA	B	WEIGHT [KG]	BORE	øC	D	E
BE 22 SKM	Low	36	141	1.5	ø 16	35	10	4
	High	36	109	0.9	ø 22	40	8	5
BE 33 SKM	Low	40	149	2.0	ø32	50	12	5
	High	40	115	1.4				

Necessary components

TOOL HOLDERS	TYPE	PAGE
	Nuts For ø 16 mm, ø 22 mm and ø 32 mm bore	
	Collet Chucks ER11 ø 1.0-7.0 mm ER20 ø 1.0-13.0 mm ER32 ø 2.0-20.0 mm	47
COLLETS	TYPE	PAGE
	ER11 ø 1.0-7.0 mm ER20 ø 1.0-13.0 mm ER32 ø 2.0-20.0 mm	47

Accessories

CONTROLS	TYPE	PAGE
	Controls for BE SKM-units	51

MULTI-SPINDLE HEADS

MULTI-SPINDLE HEADS

Ahead is information on the range of multi-spindle heads available from E2. Multi-spindle heads enable tools to be closer together than with separate units, and all holes can be worked simultaneously without having to control numerous units.

Most hole patterns are symmetrical and therefore ideal for using adjustable multi-spindle heads. It is also often possible to produce non-symmetrical patterns using these. E2 offers assistance in checking the feasibility of using an adjustable head.

Adjustable multi-spindle heads can be divided into the following four basic types:

- 2-spindle heads
- 3-spindle heads (centre spindle fixed)
- 3-spindle heads (all spindles adjustable)
- 4-spindle heads

When adjustable heads aren't suitable for the pattern to be produced or don't have enough spindles, special heads with fixed spindles can be used. These heads also offer extra precision and high repeatability for operations. All E2 units suitable for adjustable multi-spindle heads can also be fitted with fixed heads. For more information or a quote, contact E2.

PLEASE NOTE

- that multi-spindle heads reduce the idling speed as well as the speed and torque at maximum output for all units with pneumatic spindle drive. The effect on idling speed ranges from -5% for a small 2-spindle head on a low speed BE33 to -30% for a large 3 or 4-spindle head on a high speed BE22. This has been taken into account in the Guidelines in each unit's details.
- when tapping with the BEG 48 or BEG 55 you need length compensation on all spindles. This can be achieved by using collets with float compensation or tapping spindles. See Tool Holders (page 52) for more information.

MULTI-SPINDLE HEADS

DIMENSIONS FOR E2 MULTI-SPINDLE HEADS

This first section, with information on E2's range of multi-spindle heads, is followed by a section showing specifications of feasible head and unit combinations for drilling and tapping. Other combinations are possible for special applications like counter-sinking, reaming, etc, as well as heads with fixed spindles in patterns according to customer specification. Please contact E2 for further information.

The collets needed for the tool holders on E2's multi-spindle heads are described in more detail in Tool Holders (page 51).



2-SPINDLE HEADS

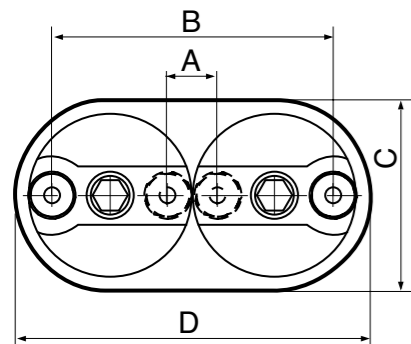

Specifications						
MODEL	MAX CAPACITY IN STEEL		COLLETS FOR MAX Ø [mm]	COLLET TYPE	MAX SPEED [rpm]	WEIGHT EXCL. ADAPTOR [kg]
	DRILLING Ø [mm]	TAPPING [M-threads]				
VH 042P	5	M3	5	ER8	4 000	0.95
VH 062P	7	M5	8	ER11	4 000	1.65
VH 082P	10	M5	12	ER16	4 000	2.20
VH 102P	12	M6	12	ER16	3 500	3.50
VH 132P	14	M6	15	ER20	3 000	5.30
VH 182P	16	M8	16	ER25	2 500	8.30

Dimensions [mm]				
MODEL	A MIN SPINDLE SPACING	B MAX SPINDLE SPACING	C SHORTER SIDE	D LONGER SIDE
VH 042P	12	72	49	91
VH 062P	17	93	65	120
VH 082P	24	108	75	141
VH 102P	28	120	83	157
VH 132P	35	151	102	195
VH 182D	41	173	122	229

3-SPINDLE HEADS (centre spindle fixed)

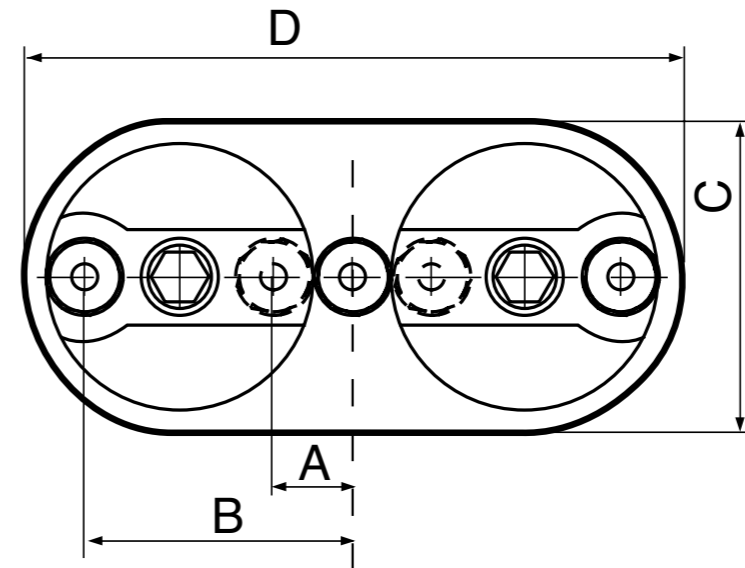

Specifications						
MODEL	MAX CAPACITY IN STEEL		COLLETS FOR MAX Ø [mm]	COLLET TYPE	MAX SPEED [rpm]	WEIGHT EXCL. ADAPTOR [kg]
	DRILLING Ø [mm]	TAPPING [M-threads]				
VH 043LP	5	M3	5	ER8	4 000	1.05
VH 063LP	7	M5	8	ER11	4 000	1.95
VH 083LP	10	M6	12	ER16	4 000	2.90
VH 103LP	12	M8	12	ER16	3 500	4.90
VH 133LP	14	M12	15	ER20	3 000	7.20
VH 183LP	16	M14	16	ER25	2 500	10.75

Dimensions [mm]				
MODEL	A MIN SPINDLE SPACING	B MAX SPINDLE SPACING	C SHORTER SIDE	D LONGER SIDE
VH 043LP	12	42	49	103
VH 063LP	17.5	55.5	65	138
VH 083LP	24	66	75	165
VH 103LP	28	74	87	189
VH 133LP	35	93	102	230
VH 183LD	41	107	122	270

3-SPINDLE HEADS

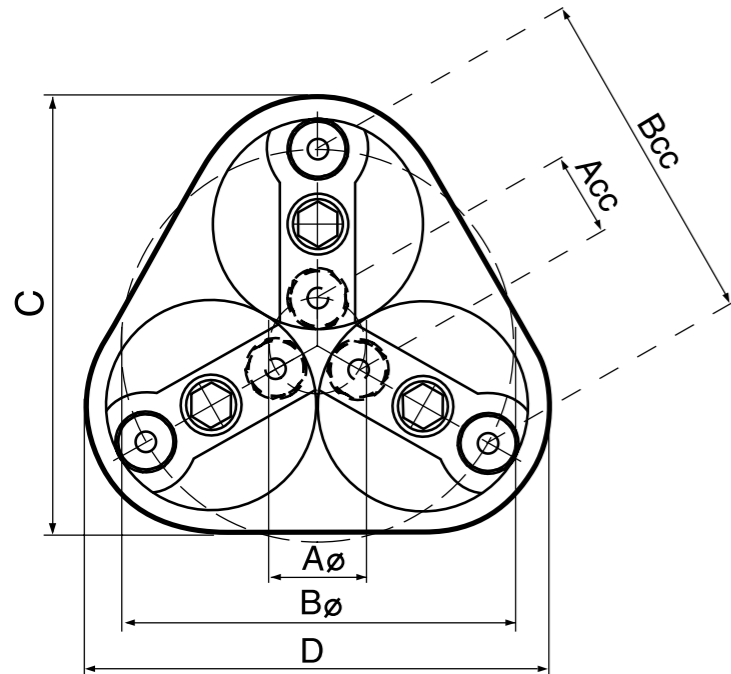

Specifications

MODEL	MAX CAPACITY IN STEEL		COLLETS FOR MAX Ø [mm]	COLLET TYPE	MAX SPEED [rpm]	WEIGHT EXCL. ADAPTOR [kg]
	DRILLING Ø [mm]	TAPPING [M-threads]				
VH 043P	5	M3	5	ER8	4 000	1.4
VH 063P	7	M5	8	ER11	4 000	2.3
VH 083P	10	M6	12	ER16	4 000	3.4
VH 103P	12	M8	12	ER16	3 500	4.9
VH 133P	14	M12	15	ER20	3 000	8.3
VH 183D	20	M14	-	TR28	2 500	12.0

Dimensions

MODEL	A MIN SPINDLE SPACING		B MAX SPINDLE SPACING		C SHORTER SIDE	D LONGER SIDE
	Ø	CC	Ø	CC		
VH 043P	18.5	16	78.5	68	86	91
VH 063P	27	23.5	103	89	113	119
VH 083P	36	32	120	104	134	142
VH 103P	40	35	132	115	148	157
VH 133P	51	44.5	167	144	184	195
VH 183D	59	52	191	165	216	229

4-SPINDLE HEADS

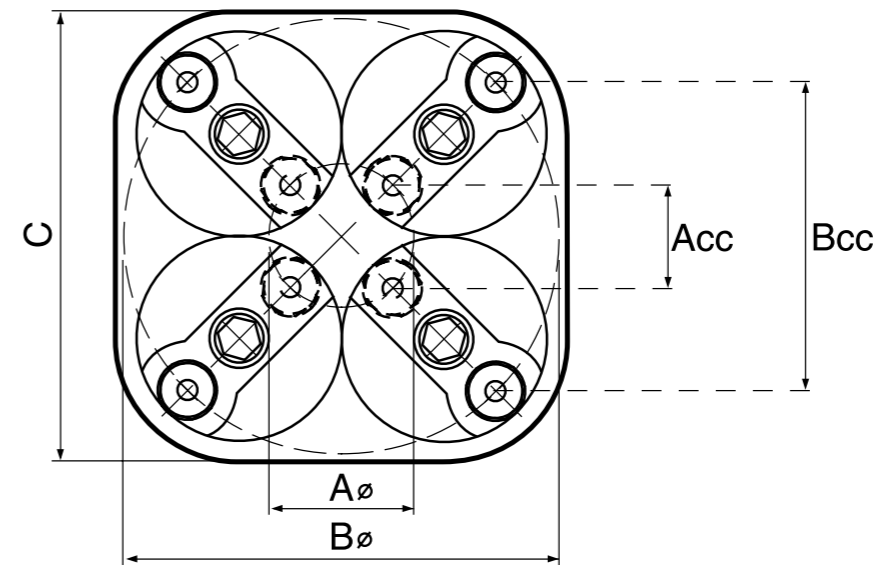

Specifications

MODEL	MAX CAPACITY IN STEEL		COLLETS FOR MAX Ø [mm]	COLLET TYPE	MAX SPEED [rpm]	WEIGHT EXCL. ADAPTOR [kg]
	DRILLING Ø [mm]	TAPPING [M-threads]				
VH 044P	5	M3	5	ER8	4 000	1.9
VH 064P	7	M5	8	ER11	4 000	3.1
VH 084P	10	M6	12	ER16	4 000	4.6
VH 104P	12	M8	12	ER16	3 500	7.2
VH 134P	14	M12	15	ER20	3 000	10.8
VH184D	20	M14	-	TR28	2 500	15.8

Dimensions

MODEL	A MIN SPINDLE SPACING		B MAX SPINDLE SPACING		C SIDE
	Ø	CC	Ø	CC	
VH 044P	29.5	21	89.5	63	91
VH 064P	41	29	117.5	82.5	119
VH 084P	53.5	38	137.5	97	142
VH 104P	60	42.5	152	107	158
VH 134P	75	53	191	135	196
VH 184D	86	61	218	154	230

MULTI-SPINDLE HEADS

DIMENSIONS FOR E2 UNITS WITH MULTI-SPINDLE HEADS

Below are specifications of the feasible head and unit combinations for drilling and tapping. Please also check out www.e2systems.com for CAD drawings and models of units with multi-spindle heads.

BE 22 SK and BE 33 SK

Dimensions [mm]				
MODEL	A	B	C	D
VH 042P / 043P / 043LP / 044P	22	25	97	50
VH 062P / 063P / 063LP / 064P	25	34	136	50
VH 082P / 083P / 083LP / 084P	28	40	148	50

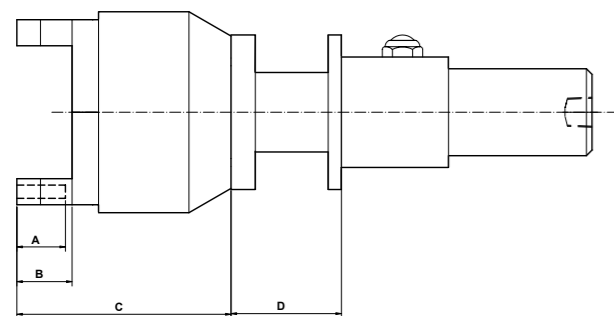

ADAPTOR WEIGHT 0.3 KG

BE(F) 22

Dimensions [mm]				
MODEL	A	B	C	D
VH 042P / 043P / 043LP / 044P	22	25	97	13
VH 062P / 063P / 063LP / 064P	25	34	136	14

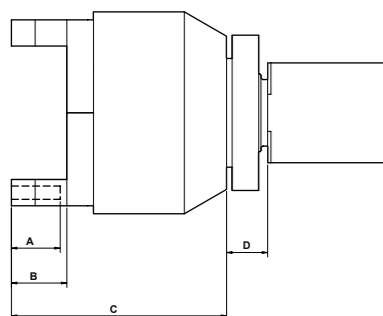

ADAPTOR WEIGHT 0.2 KG

BE 33

Dimensions [mm]				
MODEL	A	B	C	D
VH 042P / 043P / 043LP / 044P	22	25	97	13
VH 062P / 063P / 063LP / 064P	25	34	136	14
VH 082P / 083P / 083LP / 084P	28	40	148	14

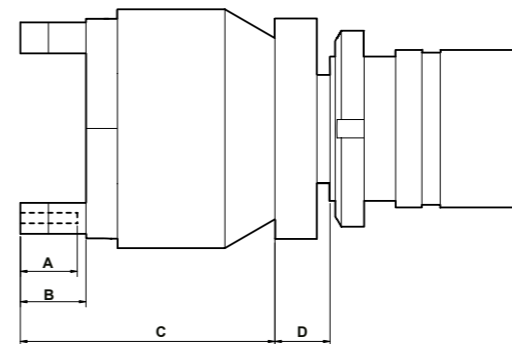

ADAPTOR WEIGHT 0.5-1.5 KG

BE 48 and BEG 48

Dimensions [mm]				
MODEL	A	B	C	D
VH 042P / 043P / 043LP / 044P	22	25	97	98
VH 062P / 063P / 063LP / 064P	25	34	136	98
VH 082P / 083P / 083LP / 084P	28	40	148	98
VH 102P / 103P / 103LP / 104P	28	40	162	104

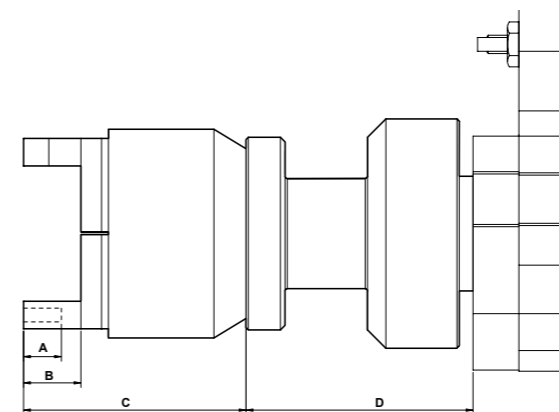

ADAPTOR WEIGHT 1.2 KG

BE 55 and BEG 55

Dimensions [mm]				
MODEL	A	B	C	D
VH 062P / 063P / 063LP / 064P	25	34	136	63
VH 082P / 083P / 083LP / 084P	28	40	148	63
VH 102P / 103P / 103LP / 104P	28	40	162	68
VH 132P / 133P / 133LP / 134P	28	55	174	72
VH 182 / 183 / 183L / 184	-	94	225	68

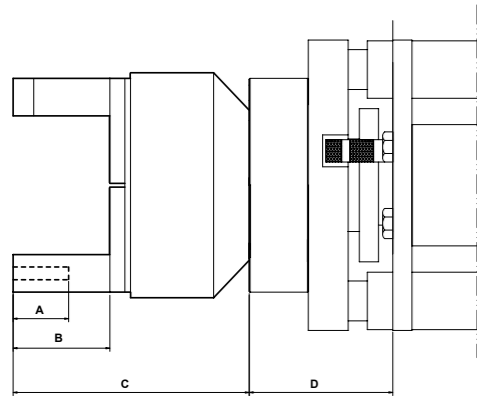

ADAPTOR WEIGHT 3.1 KG

LS 22

Dimensions [mm]			
MODEL	A	B	C
VH 042	22	25	97

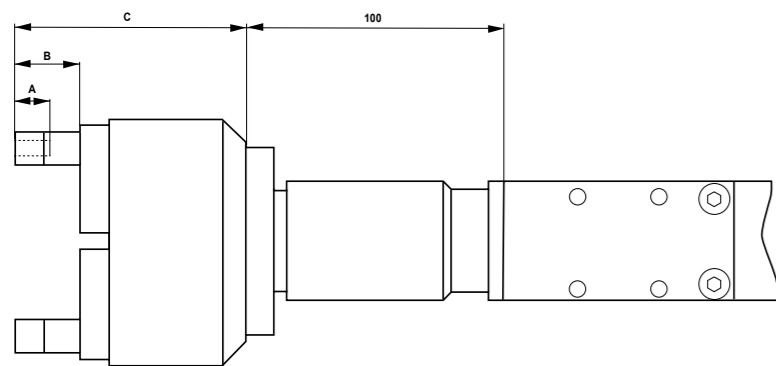

ADAPTOR WEIGHT 1.1 KG

TOOL HOLDERS

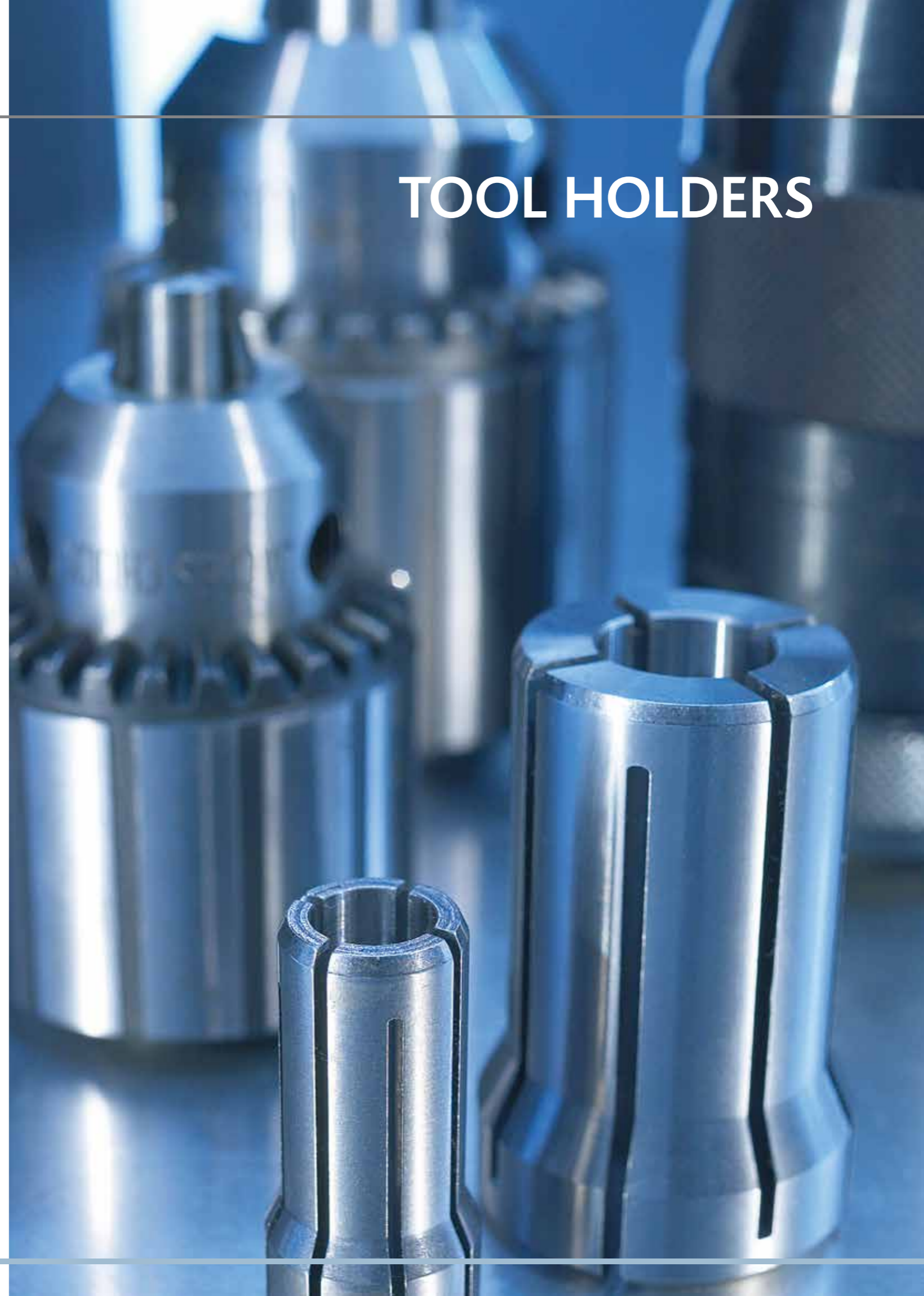

TOOL HOLDERS

All E2 units are delivered ready for tools. E2 has selected a cost-effective tool holding solution for each unit, but if the application requires other holding tools, E2 offers a wide range of options.

FOR DRILLING, E2 OFFERS

- KEY CHUCKS
- DRILL CHUCKS
- PRECISION CHUCKS
- COLLET CHUCKS AND COLLETS

FOR TAPPING, E2 OFFERS

- QUICK-CHANGE CHUCK WITH TAP HOLDERS
- COLLETS WITH LENGTH COMPENSATION
- TAPPING SPINDLES WITH LENGTH COMPENSATION AND TAP HOLDERS



DRILLING

Key chucks

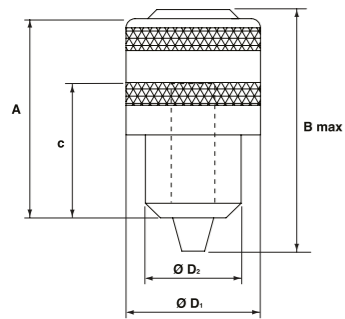

Dimensions [mm]					
KEY CHUCKS	A	B	C	D1	D2
0.5-6.5 3/8"-24	42.5	53	17	29.5	21
0.8-10.0 3/8"-24	49.5	61	24.5	34	24.5

Drill chucks

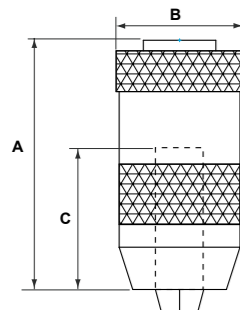

Dimensions [mm]			
DRILL CHUCKS	A	B	C
0-10.0 JT2	83	ø42.5	20-31
3.0-16.0 JT2	95	ø46	20-39

When it's time to change tools, many people prefer using self-tightening keyless chucks for rapid tool changing.

DRILLING

Precision chucks

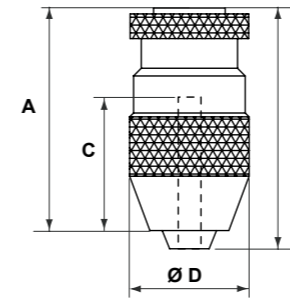

Dimensions [mm]				
PRECISION CHUCKS	A	B	C	D
0-3.0 B10	44	47.5	ca 11-15	ø24
0-5.0 B10	56	61.5	ca 12-18	ø30
0-8.0 B10	69	77.5	ca 16-24	ø38

The E2 selection of precision chucks has been chosen to maintain the unit's precision as far as possible right through to the tool. Keyless self-tightening chucks as well as collet chucks are available.

Collet chucks and Collets

Collet chuck systems offer more reliable clamping with regard to repeatability plus precision and clamping force.

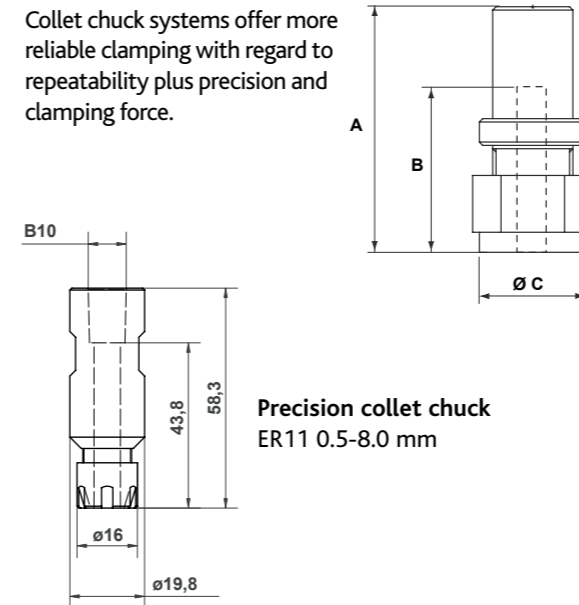

Dimensions [mm]			
COLLET CHUCKS	A	B	C
1.0-10.0 DA200 3/8"-24	49	ø36	ø20.5
3.0-20.0 DA180 3/8"-24	63	ø46.5	ø43.5
2.0-14.0 DA100 JT2	71	ø48	ø36.5
3.0-20.0 DA 180 MT2	63	ø46.5	38

Here we present the specifications of collets for the above chucks, as well as the integrated tool holders that are used in E2 range of multi-spindle heads.

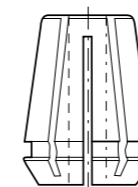

Dimensions [mm]				
COLLETS	NOMINAL		INCREMENTS	CLAMPING RANGE
	Min ø	Max ø		
ER8	1.0	5.0	0.5	-0.5
ER11	1.0	8.0	0.5	-0.5
ER16	1.0	12.0	0.5	-1.0*
ER20	1.0	15.0	0.5	-1.0*
ER32	2.0	20.0	0.5	-1.0

Clamping range -0.8 mm i.e ø 10.0 covers 9.2-10.0 mm
 *ER16 and ER20 Clamping range only 0.5 mm at 1.0 and 1.5 mm nominal diameter
 **0.1 mm up to 10.0 mm diameter

TAPPING

Quick-change chucks with Tap holders

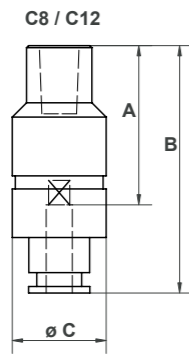
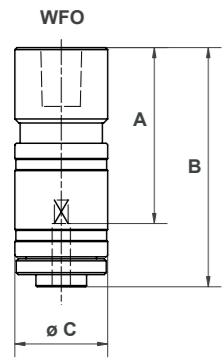

Dimensions [mm]			
CHUCKS	A	B	C
WFO B10	43.4	59.0	ø22.9
WFO B12	46.9	62.5	ø22.9
C8 JT1	39.0	60.6	ø23.0
C12 B12	44-49	64-66	ø30.0

Available in ISO, ANSI and DIN.

Collets with length compensation

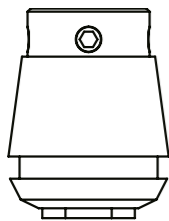

For tapping when relatively short length compensation is required, E2 offers ER collets with expansion compensation suitable for use with E2 units. These can be used in all ER chucks and tool holders (on multi-spindle heads) made for ER collets.

Specifications [mm]					
COLLETS	SHAFT DIAMETER		THREAD SIZE		LENGTH COMPENSATION
	Min ø	Max ø	Min	Max	Max
ER16-ET1 16	1.4	6.3	M0.7	M6	7
ER20-ET1 20	2.2	7.0	M1	M8	7
ER32-ET1 32	4.5	12.5	M4	M12	10

Available in ISO, ANSI and DIN.

Tapping spindles with length compensation and Tap holders

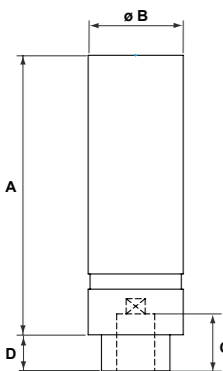

Dimensions [mm]					
TAPPING SPINDLE	A	B	C	D	LENGTH COMPENSATION
GS12E JT2	108-133	ø30	17-20	15-17	25
GS24E B18*	147-187	ø50	30	19-29	40

Available in ISO, ANSI and DIN.

When greater length compensation is required, E2 offers tapping spindles. These tapping attachments provide maximum total length compensation that can be used for expansion, compression or both.

* BEG 48 ER 32 + B18/ø16 taper shank
 BEG 55 MT2 + B18/MT2 taper shank

CONTROLS



CONTROLS

E2's units are designed for automation and are simple to connect. The following installation example shows connections and the peripheral equipment required by the units. When installing several pneumatically-operated units, we recommend that each unit have an individual sensor and individual main valves. The wiring circuit show which valves/sensors are integrated into the units.

BE 11 / HFS 100

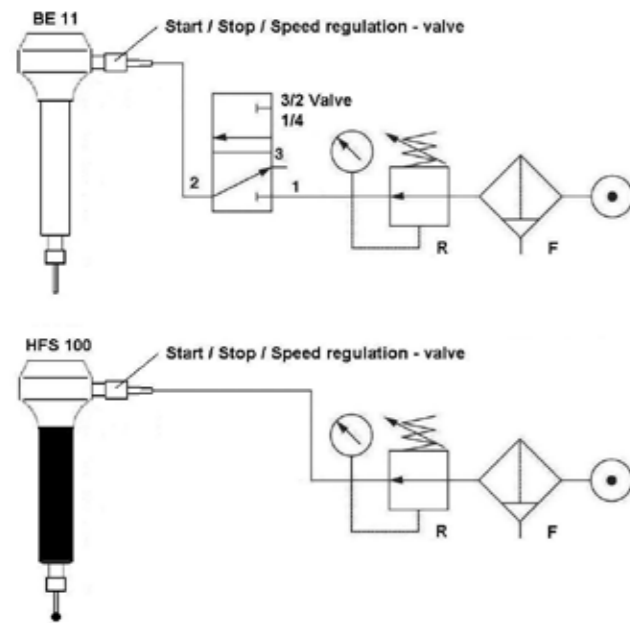

Working Pressure	4-6.3 bar
Air	Clean and dry

BE 22 SK(M) and 33 SK(M)

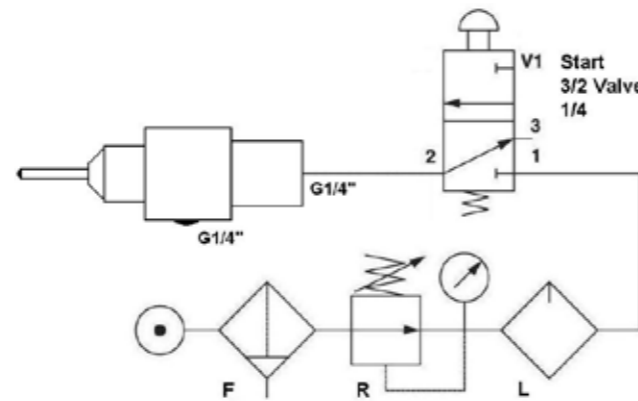

Working Pressure	6-7 bar
Air	Clean, dry and with oil mist (lubrication).
Options	Motor for air with no lubricator. Central silencer

BE(S) 21

Pneumatic limit switches

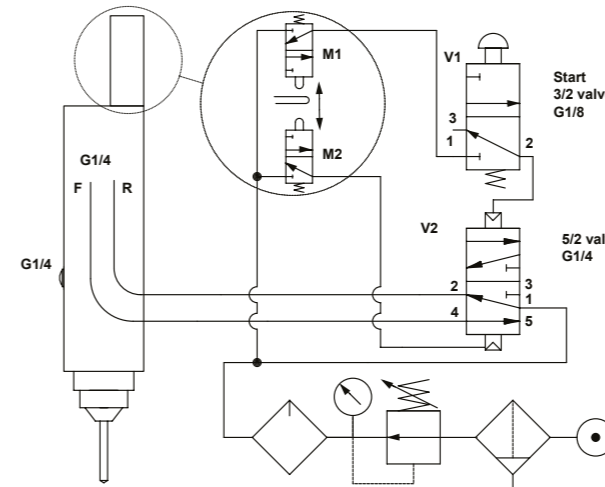

Electric limit switches

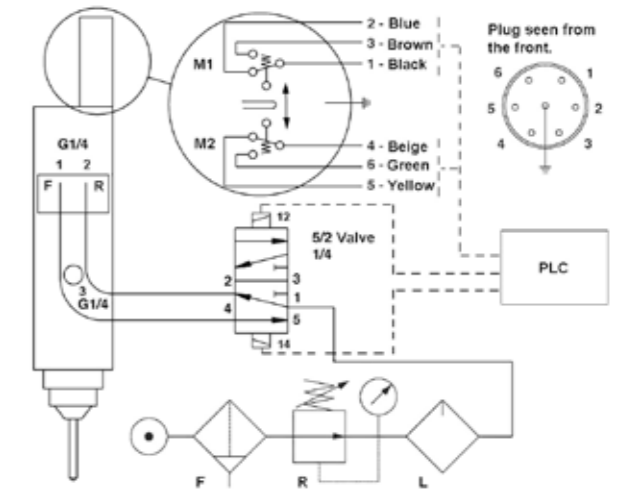

The max load for the switches at 220V is 1A.

The limit switches come with either 1.2 m hose (Pn) or 1.2 m cable (El).

We recommend a delayed return for accurate drilling depth tolerances and for countersinking.

The rotation of the spindle starts when the unit is fed air for forward feed. During the return the rotation gradually slows to a complete stop.

Working Pressure	6-7 bar
Air	Clean, dry and with oil mist (lubrication).
Options	Motor for air with no lubricator. Emergency break valve parallel to M2, which stops the unit and returns it to home position. Central silencer

BE 22 and BE 33

Pneumatic limit switches

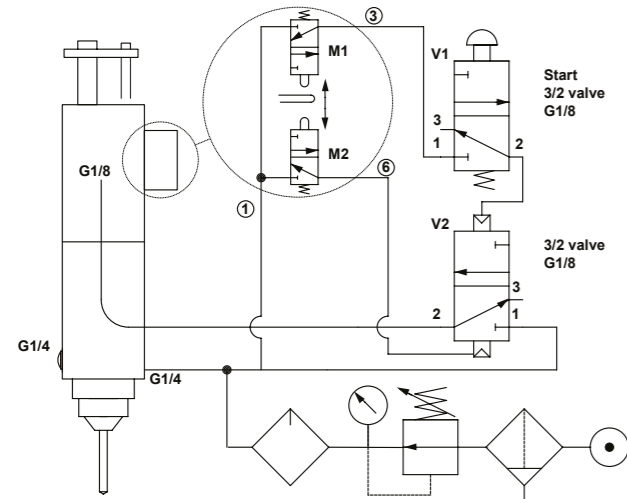

Electric limit switches

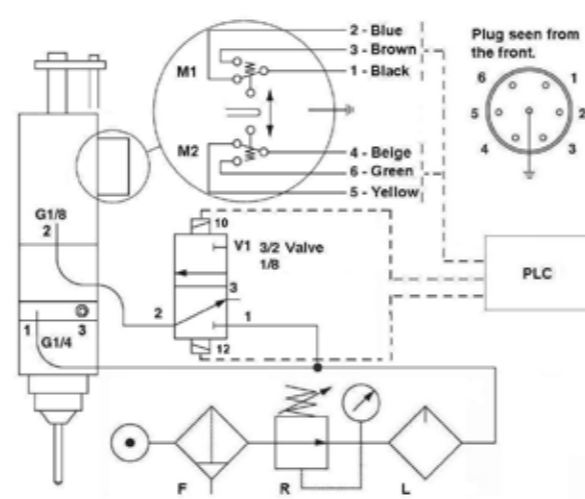

The max load for the switches at 220 V is 1A.

The limit switches comes with either 2 m hose (Pn) or 2 m cable (El).

We recommend a delayed return for accurate drilling depth tolerances and for countersinking.

When the main valve is actuated, spindle feed and rotation commence. When the valve is released, the spindle returns to its start position and the motor's rotation ceases.

Working Pressure	6–7 bar
Air	Clean, dry and with oil mist (lubrication).
Options	Motor for air with no lubricator. Emergency break valve parallel to M2, which stops the unit and returns it to home position. Central silencer

BE 48 and BEG 48

Pneumatic limit switches

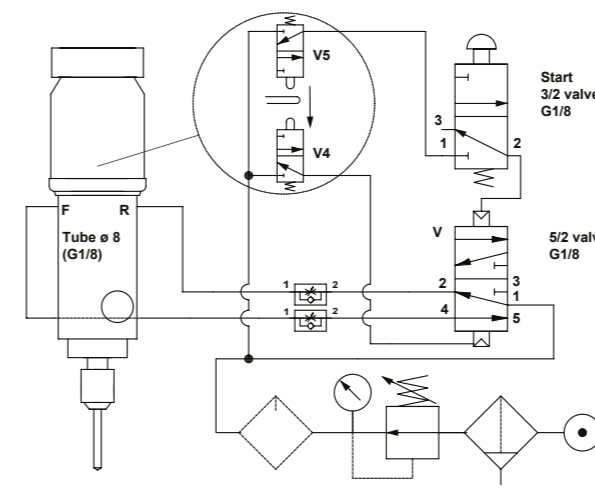

Electric limit switches or Linear transducer

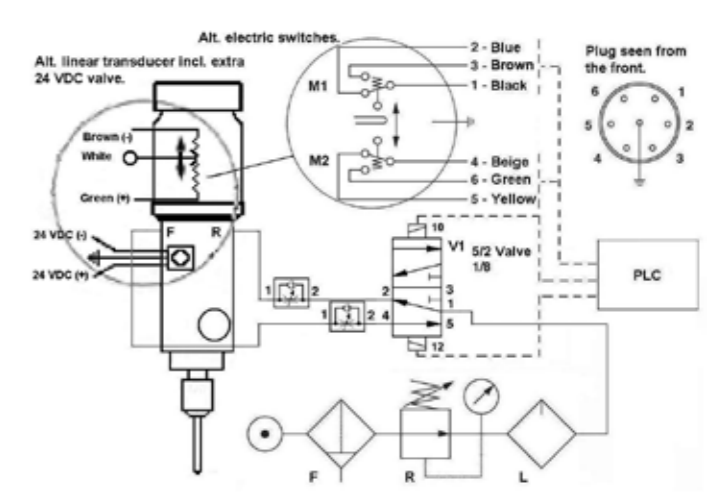

The max load for the switches at 220 V is 1A.

Linear transducer (optional) for full control of the stroke. Ideal for the control of automatic chip removal, multiwall drilling, tapping, reaming etc.

The limit switches comes with either 2 m hose (Pn) or 2 m cable (El).

We recommend a delayed return for accurate drilling depth tolerances and for countersinking.

Working Pressure	Max 8 bar
Air	Clean and dry. Lubrication is not necessary but increases the life span of the unit.
Options	Emergency break valve parallel to V4 (unit returns to home position, the spindle must be shut off electrically)
Motor	The electrical motors are 3-phase and designed to work with both 50 and 60 Hz. Connect the motor via an overload cut-out to provide protection against overloading. Standard units can be operated via frequency converters, normally in the speed range 30–150 %. When tapping with reversible motor you must add a pole reversal contactor to the system.

BE 55 and BEG 55

Control systems and electrical connections:

The signal comes from the limit sensors of the BE(G) 55 from the control system. There is one sensor for the home and one for the extracted position. The drilling or tapping cycle/depth is controlled by a linear sensor which enables you to set the rapid feed distance, max drilling depth, chip-removal cycle and/or multi-wall drilling function.

There are two control systems to choose from:

C1A where you handle sensor signals and control valves externally (the control system has push buttons to manually control the valves for fast approach and controlled feed). Typically used together with PLC or similar.

C5A is a logic control system with integrated functions for normal cycle, chip removal and multi wall operation integrated. You only need a switch (impulse max 0.5 s) to start the operation. A ready signal will indicate when the cycle is completed.

The C5A control system and valve coils are designed for 230 V 50 Hz or 110 V 50/60 Hz. The C1A control system is powered separately by 24 VDC. Both control systems are supplied with cables for connecting external controls.

Motors

The electrical motors are 3-phase and designed to work with both 50 and 60 Hz. Connect motor via an overload cut-out to provide protection against overloading. Standard units can be operated via frequency converters, normally in the speed range 30-150 %. Note: minimum motor speed with standard hydraulic gear pump is 500 rpm. When tapping with reversible motor you must add a pole reversal contactor to the system.

LS 11 and LS 22

Pneumatic limit switches

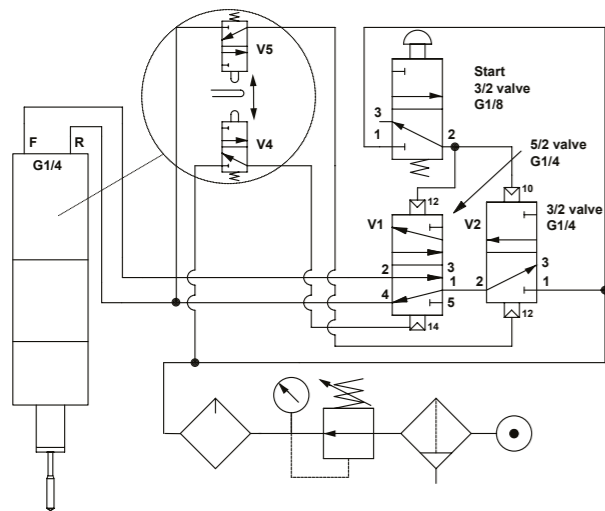

Electric limit switches

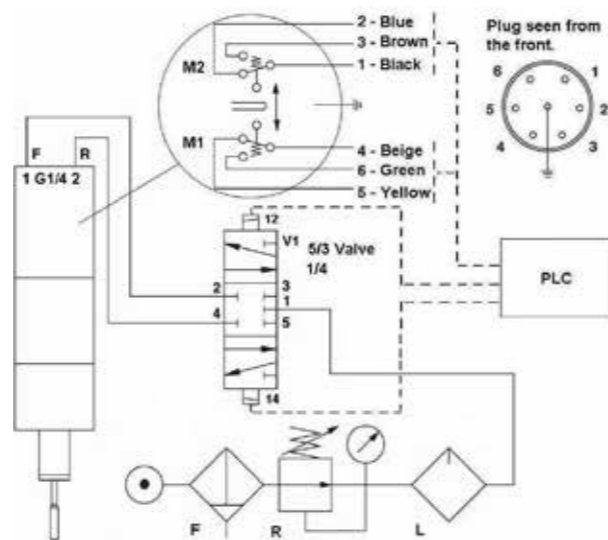

The max load for the switches at 220 V is 1A.

The limit switches come with either 1.2 m hose (Pn) or 1.2 m cable (El).

Working Pressure	6-7 bar
Air	Clean, dry and with oil mist (lubrication).
Options	Motor for air with no lubricator. Emergency break 3/2 button. Connection from main to port 14 on valve V1 (unit goes to home position)