

Medium & Heavy-Load
Assembly Automation

ISO Class 4 Verified
for Cleanrooms

Efficient, Non-Contact
Zoning

Clean, Open Roller
Design



ERT[®] 250

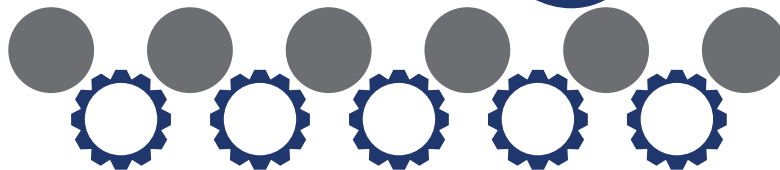

Edge Roller Technology

Precision Edge Roller Pallet &
Tray Handling Conveyors

DORNER[®]

ERT[®]250 Conveyors are best for:

- Pallet & Tray Handling
- No & Low Back Pressure Accumulation
- Cleanroom Applications
- Large & Medium Assembly Automation
- Medical Product Manufacturing
- Packaging
- Medical Device Manufacturing
- Automotive Assembly
- Electronic & Consumer Goods Assembly
- Appliance Manufacturing

Sizes & Measurements

- 120 mm to 960 mm wide
- 150 mm long tray minimum
- 38 mm diameter rollers on 50 mm centers

Loads & Speeds

- Loads: up to 114 kg (250 lbs) per pallet or tray
- Up to 6.8 kg (15 lbs) per roller
- Speeds: up to 37 m/min (121 ft/min)

Slip & Driven Rollers



Driven Roller
(over molded on shaft)



Slip Roller



Slide Rail Options

Aluminum frame with two T-Slot options



T-Slot Rail



Flush Side Rail (Cleanroom)

Pallets

- 320 to 800 mm pallets
- Static conductive HPDE skirt
- Proximity sensor pick-up on side and bottom
- Optional pin tracking ball bearings for corner conveyors

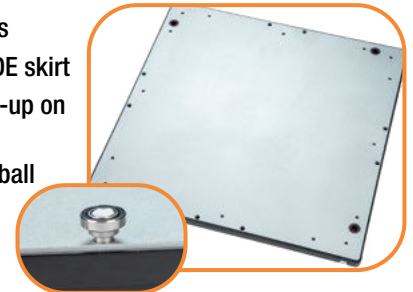

Modules



Lift & Locate



Lift & Rotate



Lift & Transfer



90 & 180 Degree Corners



Pallet Pusher



Pallet Stops

Zone & Slip Roller Technology

- Non-contact zone control provides simplified traffic control, eliminating pallet stops and costly pneumatic valves
- Low back pressure slip rollers can be used for full length with conventional pneumatic pallet stops
- Individual rollers can be replaced if damaged without affecting the remaining portion of the conveyor
- No belts, reducing product contact and debris



Easily Reconfigurable

- Gears, drive shaft, and gearmotor can be repositioned in the field
- The gearmotor can be moved on 250 mm increments
- Lower gears can be removed and gearmotor added to create new zones
- The drive shaft can be moved to any roller zone
- The drive shaft can be relocated to the lower height for added product clearance

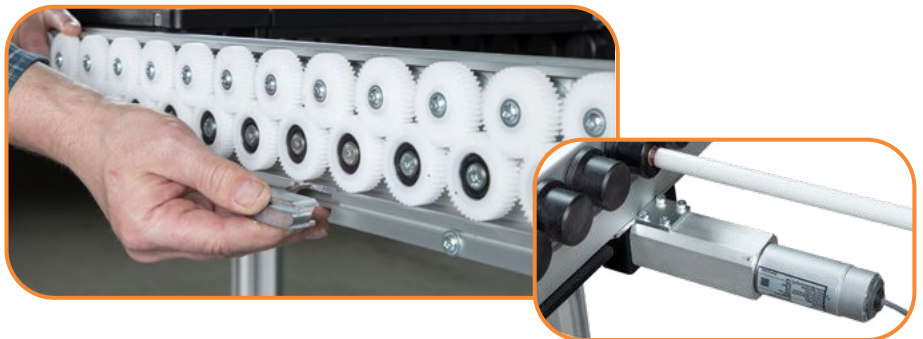

Patent Pending Gearbox Drive Design

- Durable, patent pending linear gearbox design provides a robust and flexible method of driven rollers
- Brushless DC gearmotors and controllers
- Reversible motors for assembly automation
- 50 watt, 3.5 amp, low voltage brushless DC motors are used to save space and provide improved efficiency
- All motor controllers are Ethernet IP, Modbus TCP or PROFINET for ease of control logic, wiring and communication



The Benefits of a Dorner ERT250 Conveyor

Industry Ready

- Reliable and adaptable edge roller platform for the conveyance of medical and cleanroom-based product assembly
- Versatile and durable low back pressure platform for the conveyance of appliance, electronics, automotive and consumer goods product assembly
- Open drive roller design with aluminum frames
- ISO Class 4 verified for cleanroom applications

Simple & Effective Design

- Non-contact zoning and/or slip roller accumulation capability
- Patent pending linear gearbox technology
- Designed for configuration and modifications in the field
- Variety of automation modules for product traffic control

Safe & Efficient

- Non-jamming; open drive rollers reduce pinch points
- Low-voltage motors are designed to reduce power consumption

Industrial & Automation Conveyors

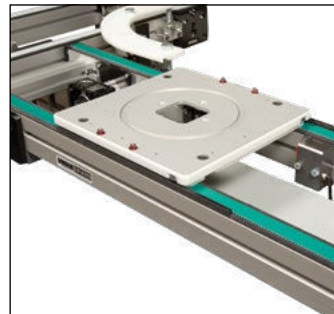
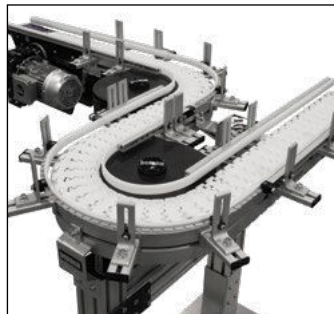

Sanitary Conveyors

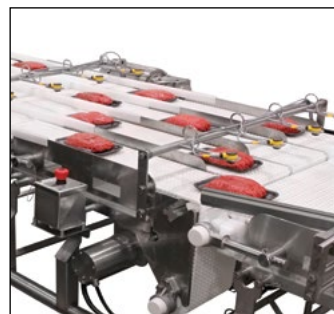
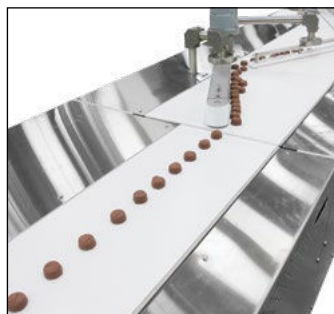

Engineered Solutions



Parts

Service

Online Configurator

Warranty