

# ENGINEERING MANUAL

Small & Light-Load  
Assembly Automation

ISO Class 4 Verified  
for Cleanrooms

Efficient, Non-Contact  
Zoning

Clean, Open Roller  
Design



# ERT<sup>®</sup> 150

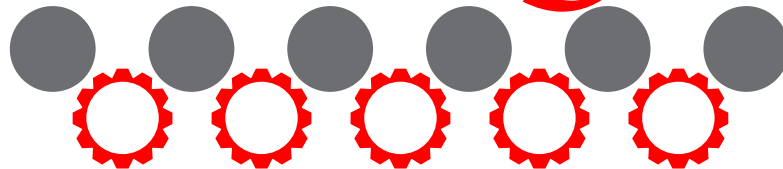

## Edge Roller Technology

### Precision Edge Roller Pallet & Tray Handling Conveyors

# DORNER<sup>®</sup>

By Columbus McKinnon

## Zone & Slip Roller Technology

- Non-contact zone control provides simplified traffic control, eliminating pallet stops and costly pneumatic valves
- Low back pressure slip rollers can be used for full length with conventional pneumatic pallet stops
- Individual rollers can be replaced if damaged without affecting the remaining portion of the conveyor
- No belts, reducing product contact and debris

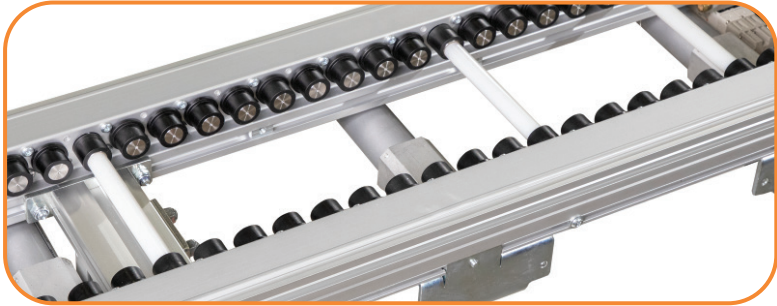

## Easily Reconfigurable

- Gears and drive shaft can be repositioned in the field
- Lower gears can be removed and gearmotor added to create new zones
- The drive shaft can be moved to any roller zone

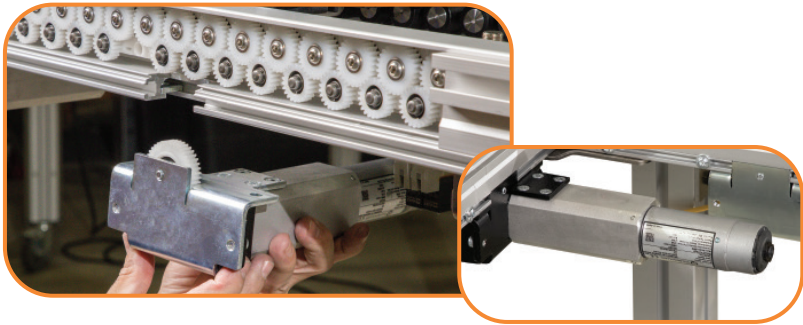

## Patent Pending Gearbox Drive Design

- Durable, patent pending linear gearbox design provides a robust and flexible method of driven rollers
- Brushless DC gearmotors and controllers
- Reversible motors for assembly automation
- 50 watt, 3.0 amp, low voltage brushless DC motors are used to save space and provide improved efficiency
- All motor controllers are Ethernet IP, Modbus TCP or PROFINET for ease of control logic, wiring and communication

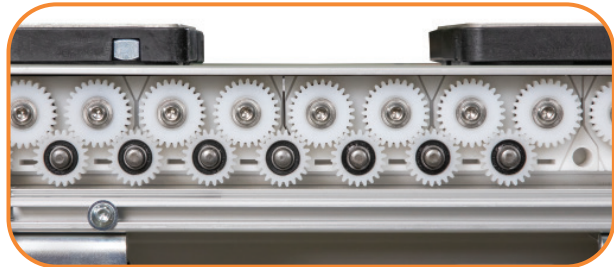

## The Benefits of a Dorner ERT<sup>®</sup>150 Conveyor

### Industry Ready

- Reliable and adaptable edge roller platform for the conveyance of medical and cleanroom-based product assembly
- Versatile and durable low back pressure platform for the conveyance of appliance, electronics, automotive and consumer goods product assembly
- Open drive roller design with aluminum frames
- ISO Class 4 verified for cleanroom applications

### Simple & Effective Design

- Non-contact zoning and/or slip roller accumulation capability
- Patent pending linear gearbox technology
- Designed for configuration and modifications in the field
- Variety of automation modules for product traffic control

### Safe & Efficient

- Non-jamming; open drive rollers reduce pinch points
- Low-voltage motors are designed to reduce power consumption

# GRAPHICAL TABLE OF CONTENTS

**CONTROLLERS  
& WIRING**  
PAGES 29-31

**GEARMOTORS**  
PAGES 28

**TURN AND  
TRANSFER**  
PAGES 14-15

**MULTI ZONE  
CONVEYOR**  
PAGES 10-11

**LIFT &  
ROTATE**  
PAGES 20-21

**LIFT &  
LOCATE**  
PAGES 16-17

**LIFT &  
TRANSFER**  
PAGES 22-24

**SINGLE ZONE  
CONVEYOR**  
PAGES 8-9

**PALLET  
STOPS**  
PAGES 25-27

**PALLETS**  
PAGES 12-13

**PALLET  
PUSHER**  
PAGES 18-19

**SUPPORT  
STANDS**  
PAGE 32

**CONVEYOR  
FEATURES**  
PAGES 4-5

**EXAMPLE  
LAYOUTS**  
PAGES 6-7

**ENGINEERED  
SOLUTIONS**  
PAGES 35

**ACCESSORIES**  
PAGES 33-34



**TECHNICAL DATA  
& CALCULATIONS**  
PAGES 36-44

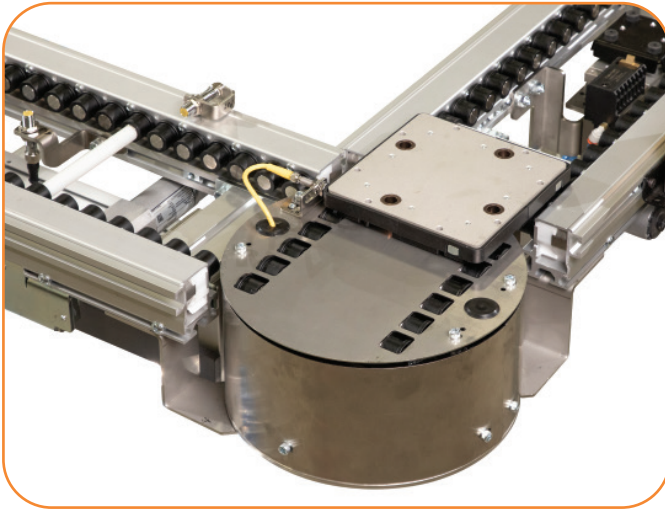

**INNOVATIVE CORNERS:**  
THE CORNER SYSTEMS PROVIDES A SIMPLE, COST EFFECTIVE MEANS FOR PALLET TRAFFIC CONTROL

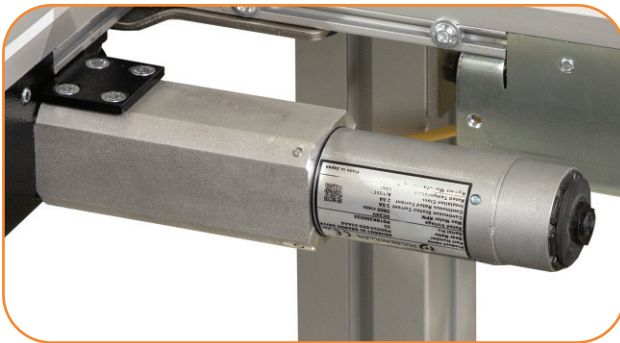

**LOW VOLTAGE GEARMOTORS:**  
COMPACT, COST EFFICIENT 24 VDC BRUSHLESS GEARMOTORS AND CONTROLS PROVIDE A MODULAR CONTROL SCHEME

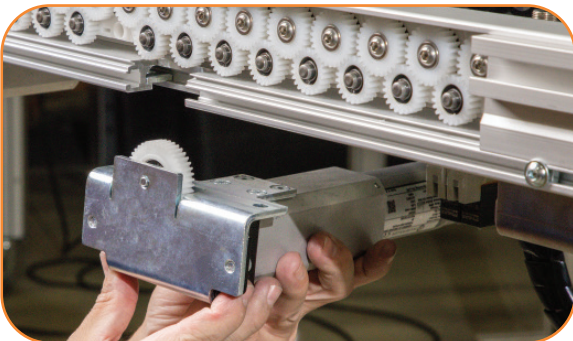

**ONSITE RECONFIGURATION AND MAINTENANCE:**  
INDIVIDUAL ROLLERS AND DRIVE SHAFTS CAN BE REMOVED, REPAIRED, AND REPOSITIONED WITHOUT DISASSEMBLY OF THE COMPLETE CONVEYOR



**UNIVERSAL T-SLOT:**  
CONVEYOR T-SLOT IS COMPATIBLE WITH DORNER 2200 SERIES AND FLEXMOVE<sup>®</sup> T-SLOT HARDWARE ALONG WITH SELECT INDUSTRY STANDARD 10 MM SLOT HARDWARE

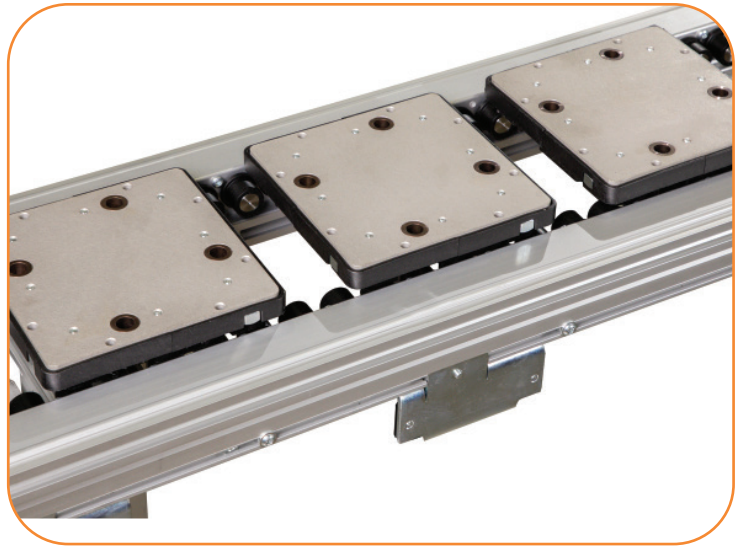
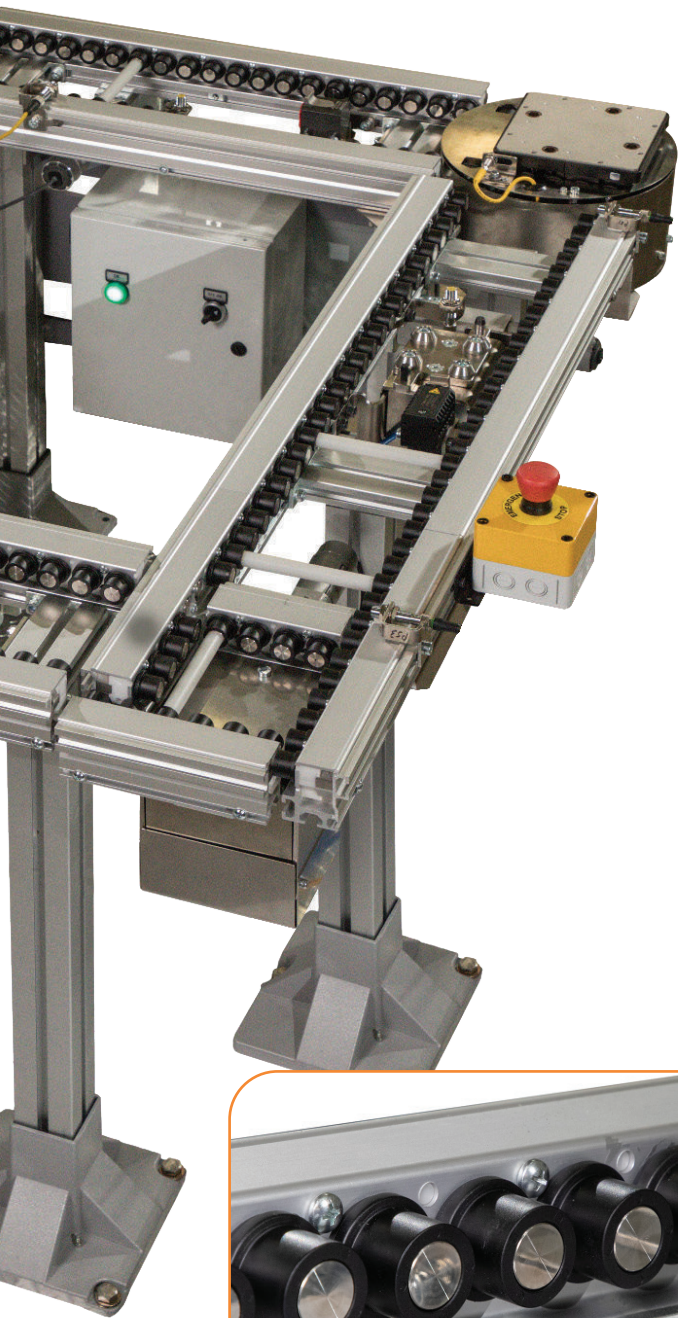

## ZONING CONVEYOR:

CONVEYOR CAPABLE OF HAVING MULTIPLE ZONES FOR PALLET OR TRAY CONTROL, ELIMINATING STOPS AND PNEUMATIC VALVES

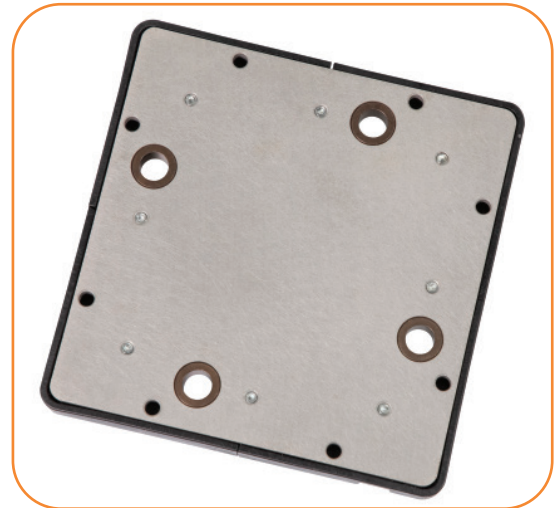

## INDUSTRY COMPATIBLE PALLETS:

PALLETS AVAILABLE IN INDUSTRY STANDARD SIZES ALONG WITH LOCATION PINS THAT ARE COMPATIBLE WITH INDUSTRY STANDARD PALLETS AND LOCATE STATIONS



## SLIP ROLLER CONVEYOR:

SLIP ROLLER DESIGN MINIMIZES BACK PRESSURE ON ACCUMULATED PALLETS OR TRAYS, ALSO ELIMINATING DUST OFTEN SEEN WITH TRADITIONAL CONVEYORS

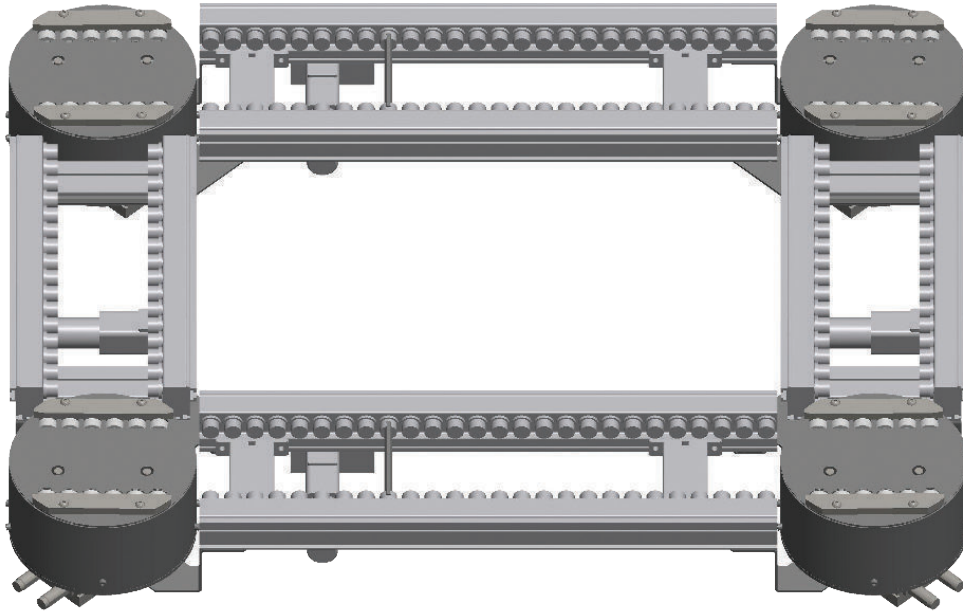

**Loop (Racetrack)**

Leading edge orientation is maintained using turn and transfer modules

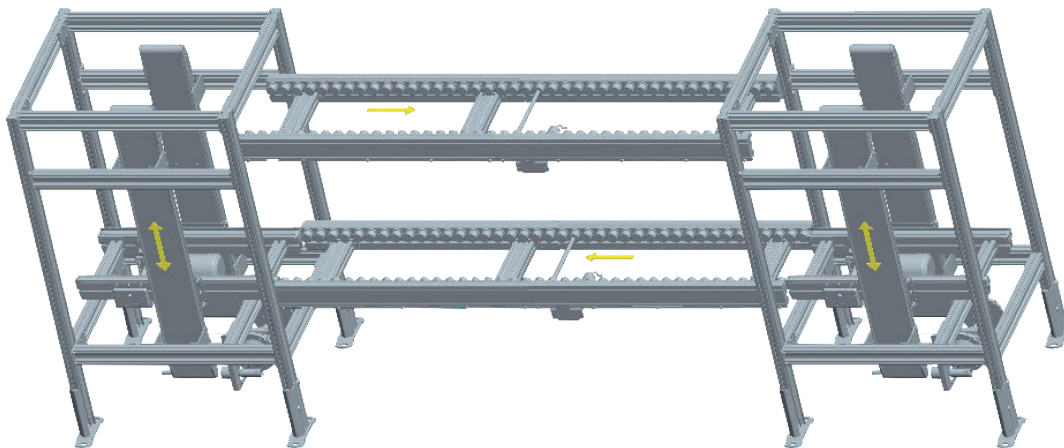

**Over Under**

The return line is located under the main line. Vertical Transfer Units (Elevators) raise and lower the pallets at each end

## Typical Application:

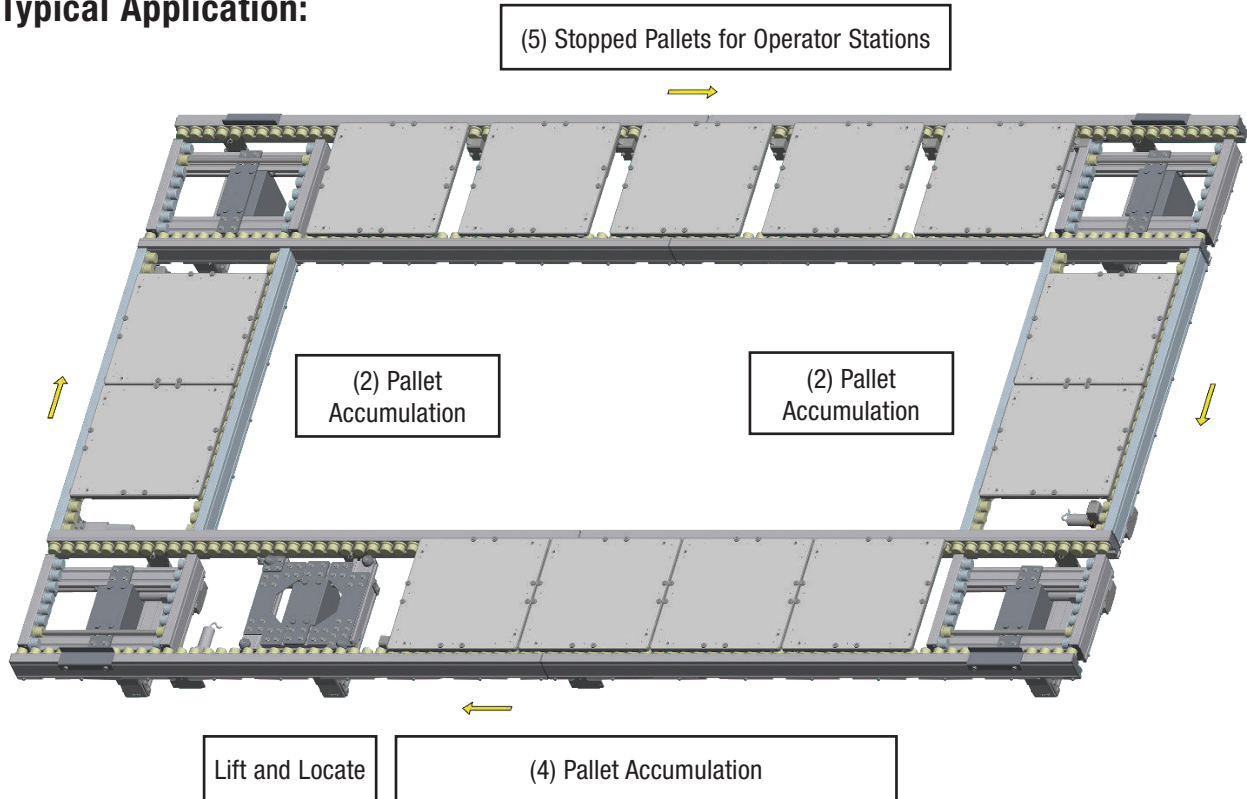

## Product Required for Slip Roller Conveyor Method:

- (2) Long conveyors – full slip rollers
- (2) Short conveyors – full slip rollers
- (4) Brushless DC gearmotors for conveyors
- (2) 24VDC gearmotor controllers
- (1) Lift and Locate Module
- (4) Lift and Transfer Modules
- (9) Pallet Stops
- (18) Pneumatic solenoid valves with air plumbing and electrical wiring

### Benefits:

- Low back pressure contact accumulation
- Continuous run gearmotors
- Low voltage gearmotor wiring

## Product Required for Zone Conveyor Method:

- (2) Long conveyors – with (5) zones each
- (2) Short conveyors – with (2) zones each
- (14) Brushless DC gearmotors
- (7) 24VDC gearmotor controllers
- (1) Lift and Locate
- (4) Lift and Transfer Modules
- (1) Pallet Stops (for Lift and Locate)
- (6) Pneumatic solenoid valves with air plumbing and electrical wiring

### Benefits:

- Non-contact pallet accumulation
- Flexibility of controlled gearmotors
- Low voltage gearmotor wiring
- Minimized pneumatics to reduce noise, wiring / plumbing costs, and solenoid hardware

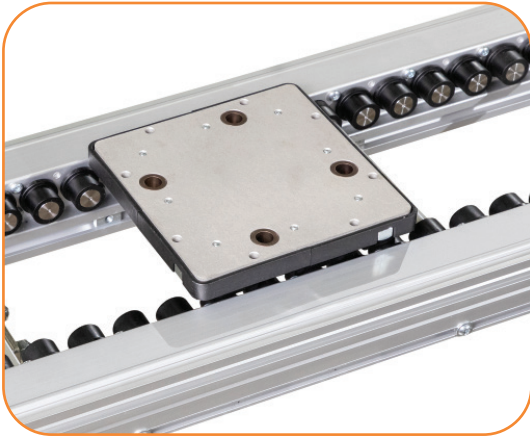

## Specifications

- 24 mm (0.95 in) diameter rollers on 32 mm (1.36 in) centers
- 80 mm (3.15 in) to 480 mm (18.9 in) wide
  - Standard pallet widths from 160 mm to 320 mm wide
- Lengths from 128 mm to 2432 mm in 64 mm increments
  - Conveyors over 1216 mm contain 2 gearmotors
  - For longer conveyors simply bolt multiple conveyors together
- Load capacity: Up to 16 kg (35 lbs) per pallet
- Up to 37 m/min (121 ft/min)
- Driven rollers for indexing / zoning and transport applications
- Slip rollers for low back pressure accumulation
- Brushless DC gearmotor and controller. See page 28-29 for specifications
  - Conveyors over 1216 mm in length contain (2) gearmotors with (1) controller
- Bi-directional and reversing
- Gearmotor can be located at multiple locations along length on 128 mm increments
- Outer frame cover: flush design or flexible T-slot options available
- Clear anodized aluminum framing
- Electrically conductive polyamide rollers
- Up to ISO Class 4 Cleanroom Rated. See page 37 for details

### Driven Rollers



### Slip Rollers



**STANDARD FEATURE:**  
Universal T-slot compatible with industry standard 10 mm hardware



**STANDARD OPTION:**  
Flush outer cover can be provided



**STANDARD FEATURE:**  
Conveyor roller provides pallet guiding



# SINGLE ZONE CONVEYOR

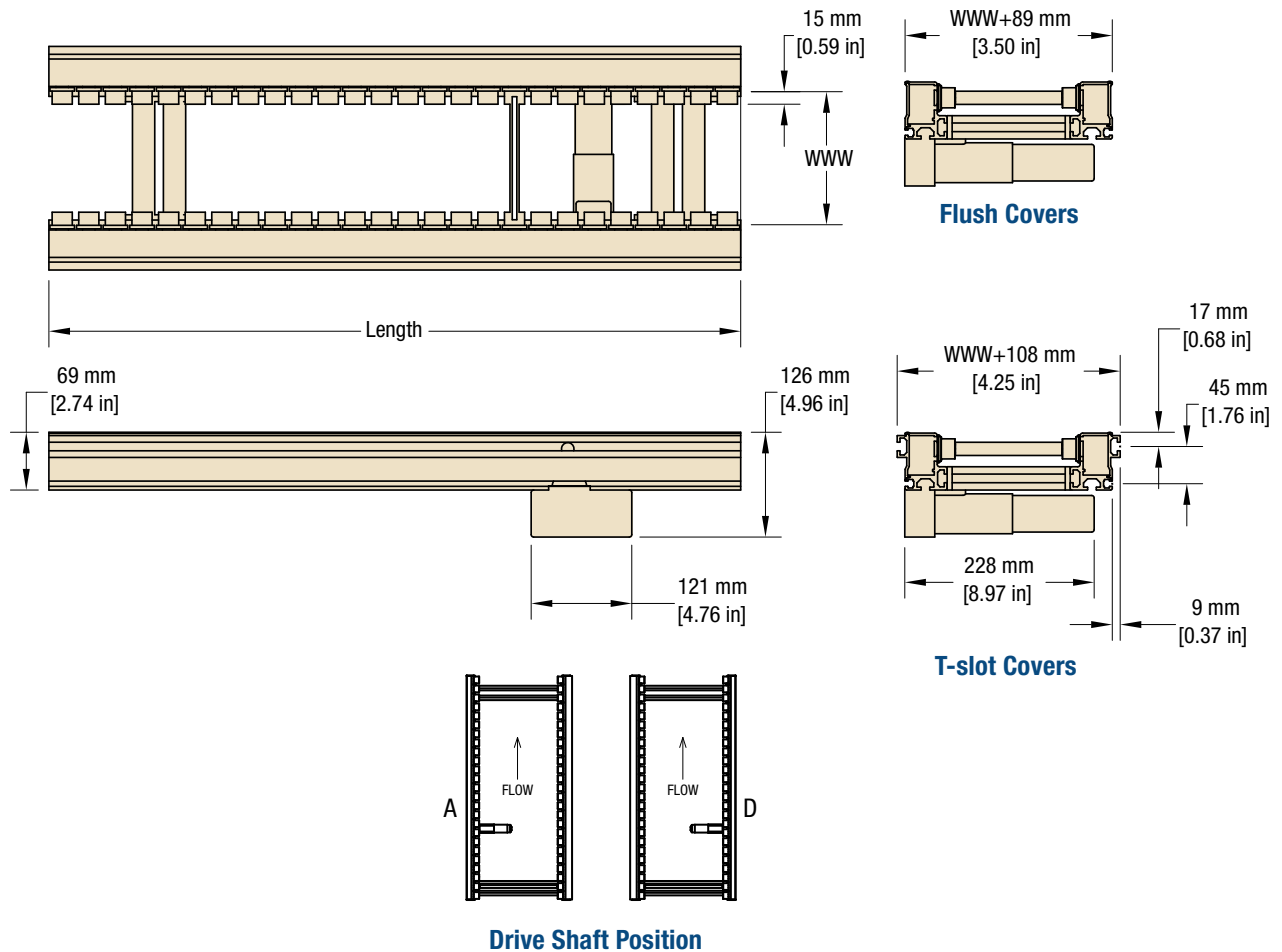

Standard Single Zone Sizes					
Conveyor Width Reference*	80	120	40 increments up to...	440	480
Conveyor Belt Width (W)*	80 mm (3.15 in)	120 mm (4.72 in)	40 mm (1.6 in) increments up to...	440 mm (17.3 in)	480 mm (18.9 in)
Conveyor Length Reference	0128	0064 increments up to...			2432
Conveyor Length (L)	128 mm (0.42 ft)	64 mm (2.52 in) increments up to...			2432 mm (8.0 ft)

\*Standard Pallet Widths: 160, 200, 240, 280 and 320 mm

**ERT150: Individual Conveyor - Single Zone**

ER3 M WWW - LLLL T R S S R S S - H D S C T

- Cover Style: T = T-slot F = Flush
- Controller Type: A = No Controller B = Controller with mount
- Speed: 1 = 87 rpm (10 mpm) 2 = 129 rpm (15 mpm) 3 = 176 rpm (20 mpm)  
4 = 215 rpm (25 mpm) 5 = 317 rpm (37 mpm)
- Motor Side: A = A Side (INSIDE) D = D Side (INSIDE)
- Drive Shaft Height: 1 = at Roller
- Second Drive Shaft Location: Roller position from Infeed End (01 to 99), (Blank if not required)
- Location of Second Gearmotor Location from Infeed End: A - X (Blank if not required)
- First Drive Shaft Location: Roller position from infeed end (01 to 99)
- Location of First Gearmotor Location from Infeed End: A - X
- Roller Type: D = Driven Roller P = Slip Roller
- Conveyor Length Reference: LLLL in millimeters 0128 to 2432 in 0064 increments (max length single zone = 1216mm)
- Conveyor Width Reference: 360, 400, 440 or 480
- Documentation Language: M = US-English U = Europe English, D = German
- Conveyor Type: ERT150

Note: Due to the wide variety of drive setups and applications, point of installation guarding is the responsibility of the end user.

Note: Dimensions = mm (in)



## Specifications

- Multiple Zone conveyor. Up to 4 zones per conveyor
- 24 mm (0.95 in) diameter rollers on 32 mm (1.26 in) centers
- 80 mm (3.15 in) to 480 mm (18.9 in) wide
  - Standard pallet widths from 160 mm to 320 mm wide
- Minimum Zone Length: 128 mm (5.0 in)
- Maximum Zone Length: 1216 mm (42.9 in)
- Length increments = 64 mm (2.52 in)
- Total maximum conveyor length: 3136 mm
- Load capacity: Up to 16 kg (35 lbs) per pallet / per zone
- Up to 37 m/min (121 ft/min)
- Driven rollers for indexing / zoning and transport applications
- Slip rollers for low back pressure accumulation
- Brushless DC gearmotor provided for each zone. Controller can drive up to 2 gearmotors. See page 28-29 for specifications
- Bi-directional and reversing
- Gearmotor can be located at multiple locations along length on 128 mm increments
- Outer frame cover: flush design or flexible dual T-slot options available
- Clear anodized aluminum framing
- Electrically conductive polyamide rollers
- Up to ISO Class 4 Cleanroom Rated. See page 37 for details

### Driven Rollers



### Slip Rollers



**STANDARD FEATURE:**  
Universal T-slot compatible with industry standard 10 mm hardware



**STANDARD OPTION:**  
Flush or T-slot outer cover can be provided

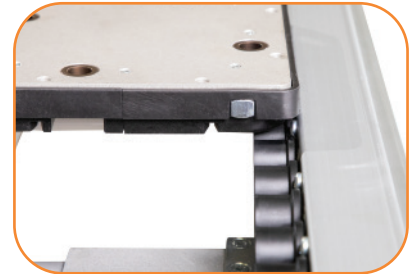

**STANDARD FEATURE:**  
Conveyor roller provides pallet guiding

# MULTIPLE ZONE CONVEYOR

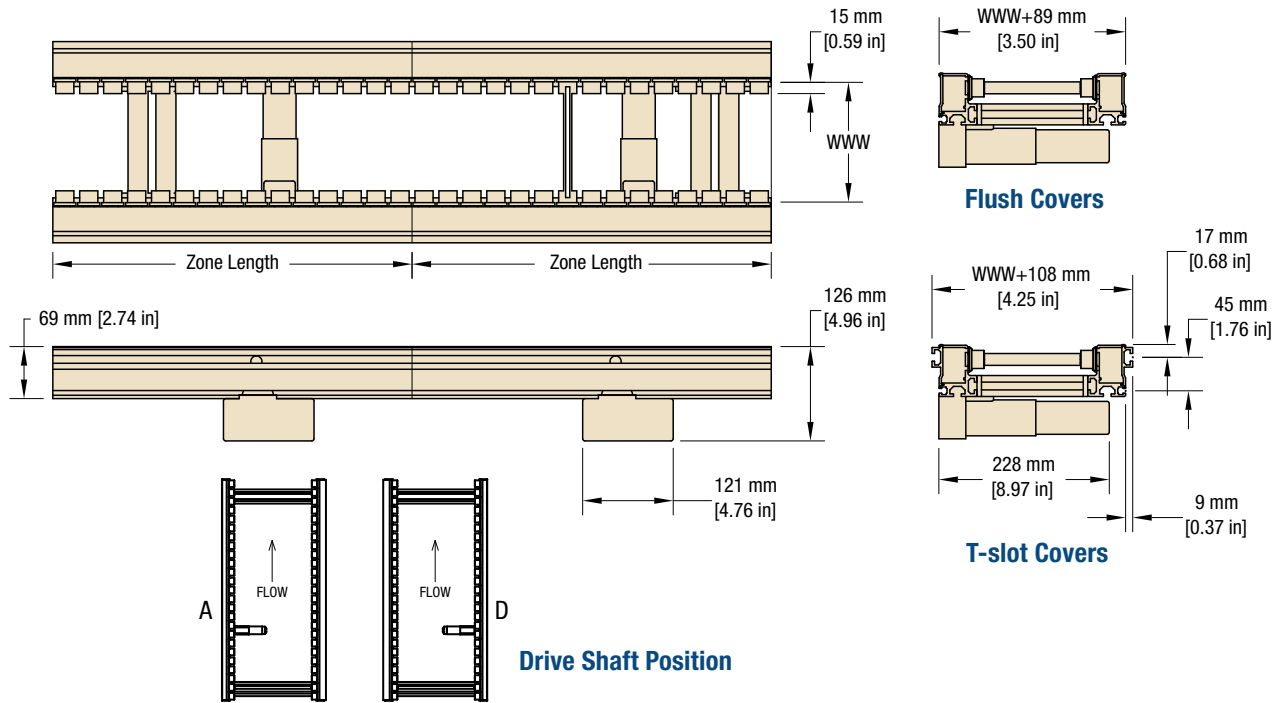

### Standard Single Zone Sizes

<b>Conveyor Width Reference*</b>	80	120	40 increments up to...	440	480
<b>Conveyor Belt Width (W)*</b>	80 mm (3.15 in)	120 mm (4.72 in)	40 mm (1.6 in) increments up to...	440 mm (17.3 in)	480 mm (18.9 in)
<b>Conveyor Length Reference</b>	0128	0064 increments up to...			1216
<b>Conveyor Length (L)</b>	128 mm (0.42 ft)	64 mm (2.52 in) increments up to...			1216 mm (4.0 ft)

\*Standard Pallet Widths: 160, 200, 240, 280 and 320 mm

### ERT150: Multiple Zone Conveyor (up to 4 Zones)

ER3	M	WWW	-	LLLL	T	R	SS	-	LLLL	T	R	SS	-	LLLL	T	R	SS	-	LLLL	T	R	SS	-	H	D	S	C	T
<p><b>Cover Style:</b> T = T-slot F = Flush</p> <p><b>Controller Type:</b> A = No Controller</p> <p>B = Controllers Only (for all mtrs)</p> <p><b>Speed:</b> 1 = 87 rpm (10 mpm) 2 = 129 rpm (15 mpm)</p> <p>3 = 176 rpm (20 mpm) 4 = 215 rpm (25 mpm)</p> <p>5 = 317 rpm (37 mpm)</p> <p><b>Motor Side:</b> A = A Side (INSIDE) D = D Side (INSIDE)</p> <p><b>Drive Shaft Height:</b> 1 = at Roller</p> <p><b>Fourth Drive Shaft Location:</b> Roller Position from Infeed End (01 to 99) (Blank if not required)</p> <p><b>Location of Fourth Drive Gearmotor from Infeed End:</b> A - X (Blank if not required)</p> <p><b>Fourth Roller Type:</b> D = Driven Roller P = Slip Roller (Blank if not required)</p> <p><b>Conveyor Fourth Zone Length Reference:</b> LLLL in millimeters 0128 to 2432 in 0064 increments (max length single zone = 1216mm)</p> <p><b>Third Drive Shaft Location:</b> Roller Position from Infeed End (01 to 99) (Blank if not required)</p> <p><b>Location of Third Drive Gearmotor from Infeed End:</b> A - X (Blank if not required)</p> <p><b>Third Roller Type:</b> D = Driven Roller P = Slip Roller (Blank if not required)</p> <p><b>Conveyor Third Zone Length Reference:</b> LLLL in millimeters 0128 to 2432 in 0064 increments (max length single zone = 1216mm)</p> <p><b>Second Drive Shaft Location:</b> Roller Position from Infeed End (01 to 99)</p> <p><b>Location of Second Drive Gearmotor from Infeed End:</b> A - X</p> <p><b>Second Roller Type:</b> D = Driven Roller P = Slip Roller</p> <p><b>Conveyor Second Zone Length Reference:</b> LLLL in millimeters 0128 to 2432 in 0064 increments (max length single zone = 1216mm)</p> <p><b>First Drive Shaft Location:</b> Roller Position from Infeed End (01 to 99)</p> <p><b>Location of First Drive Gearmotor from Infeed End:</b> A - X</p> <p><b>First Roller Type:</b> D = Driven Roller P = Slip Roller</p> <p><b>Conveyor First Zone Length Reference:</b> LLLL in millimeters 0128 to 2432 in 0064 increments (max length single zone = 1216mm)</p> <p><b>Conveyor Width Reference:</b> 360, 400, 440 or 480</p> <p><b>Documentation Language:</b> M = US-English U = Europe English D = German</p> <p><b>Conveyor Type:</b> ERT150 <b>TOTAL CONVEYOR LENGTH CANNOT EXCEED 3136 MM</b></p>																												

**Note:** Due to the wide variety of drive setups and applications, point of installation guarding is the responsibility of the end user. **Note:** Dimensions = mm (in)

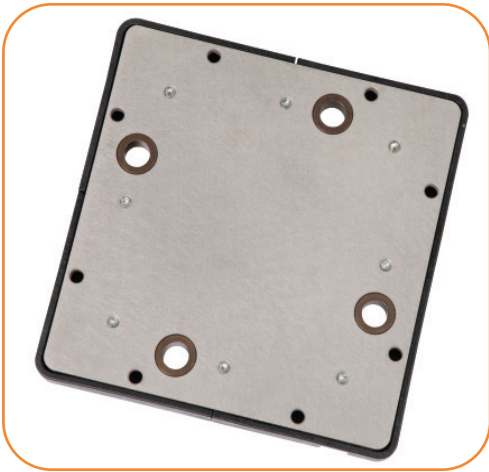

### Specifications

- Pallet is dimensionally compatible with industry standards
- Pallet Base:
  - Anodized aluminum tool plate is standard (other materials available, contact factory)
  - Thicknesses of 1/4 in to 3/8 in
- Pallet Skirt Material: Electrostatic Dissipative HPDE
- Includes (4) hardened bushings for Lift and Locate
- Load capacity to 18 kg (40 lbs)
- Plated steel proximity sensor pick-up on bottom and side of pallet
- Custom widths available
- Center of gravity of the combined payload should be located in the center third of the pallet



#### Pallet Sizes

		Length (mm)				
		160	200	240	280	320
Width (mm)	160	X		X		
	200		X			
	240	X		X		X
	280				X	
	320			X		X

#### Total Load capacity including Pallet, Fixture and Product kg (lbs):

		Length (mm)				
		160	200	240	280	320
Width (mm)	160	9.1 (20)		10 (22)		
	200		11.4 (25)			
	240	10 (22)		13.6 (30)		16 (35)
	280				16 (35)	
	320			16 (35)		18.2 (40)



**Bottom Sensing Location**



**Side Sensing Location**

**ERT150: Pallets**

ER 5 | S P M | W W W | - | L L L | A | T | O

- Pin Tracking System: 0 = Without Pin Tracking System
- Plate Thickness: 4 = 1/4 in 6 = 3/8 in
- Pallet/Bumper Options: A = Assembled with std aluminum top plate C = Kit only without aluminum top plate
- Pallet Length Reference: 160 - 320
- Pallet Width Reference: 160 - 320
- Documentation Language: M = US-English
- Conveyor Type: P = Pallet

**Note:** Pallet bumper cannot be used in applications where pallets slide against each other.

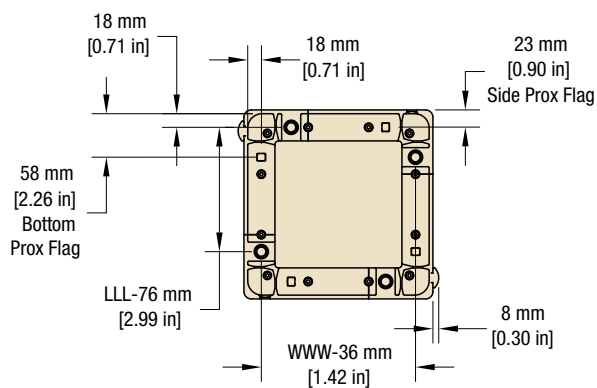
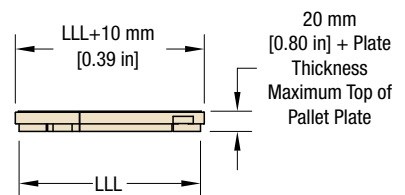
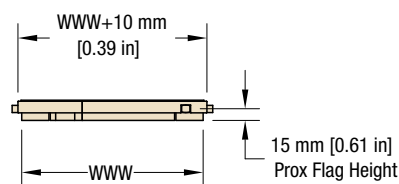
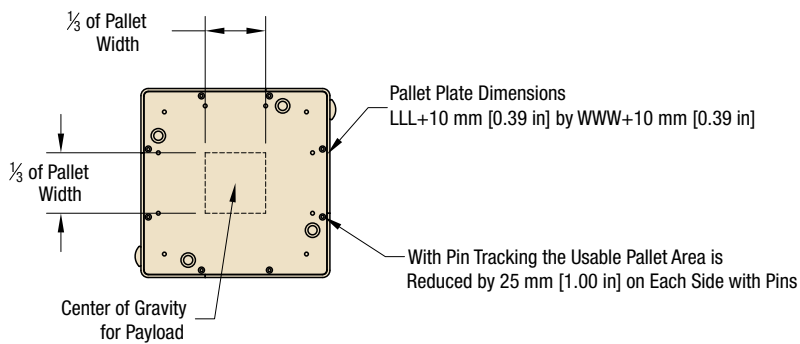
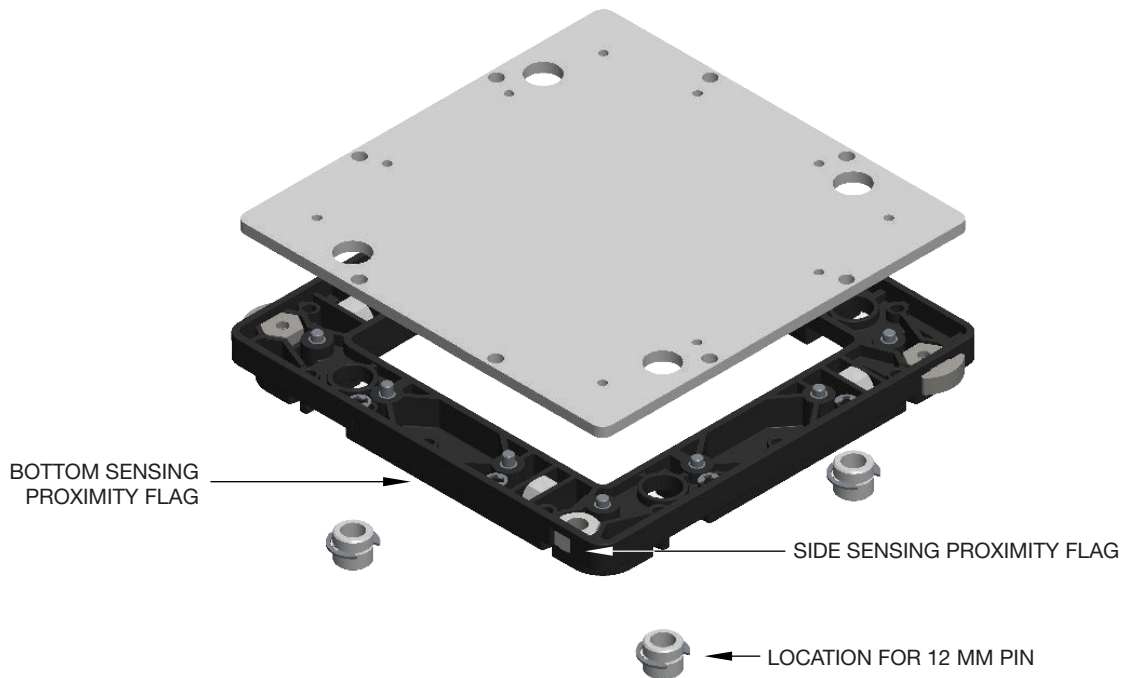

Note: Dimensions = mm (in)

See page 43 & 44 for detailed pallet weights and detailed pallet plate drawings.

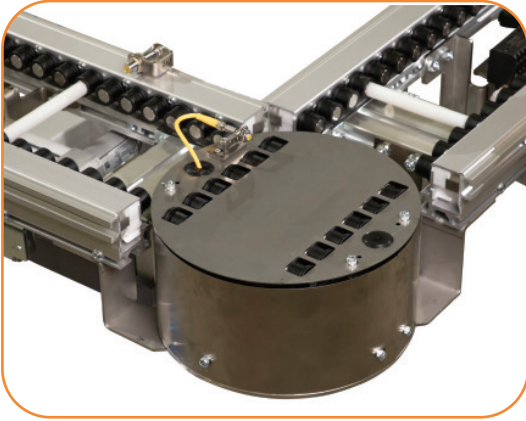

**Specifications**

- 90 degree corners
- Standard pallet widths: 160 mm, 200 mm, 240 mm, 280 mm and 320 mm wide
- Load capacity: Up to 18 kg (40 lbs) per pallet
- Up to 37 m/min (121 ft/min)
- Maintains pallet orientation around corner
- 2-way, 3-way and 4-way configurations
- Pallet accumulation in corner is acceptable
- Brushless DC gearmotor and controller. See page 28-29 for specifications
- Bi-directional
- Clear anodized aluminum framing
- Electrically conductive acetal rollers

**Configurations**

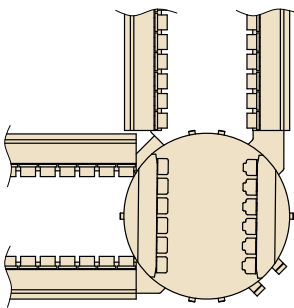

2-Way

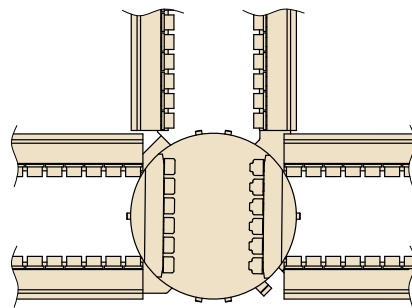

3-Way

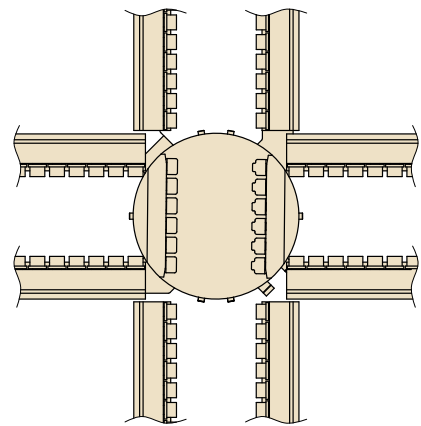

4-Way

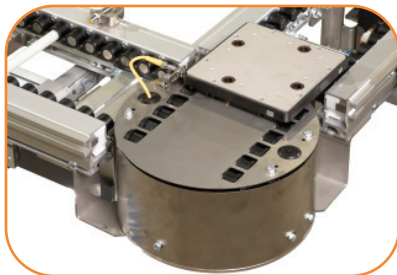

**STANDARD FEATURE:**  
Fully enclosed rotary device for operator safety

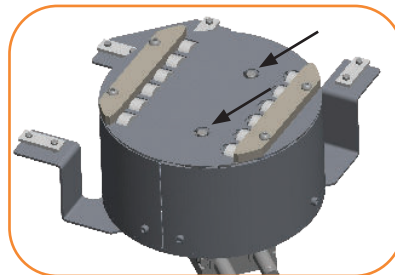

**STANDARD FEATURE:**  
Includes Pallet sensor brackets for 12 mm proximity sensor located inside housing

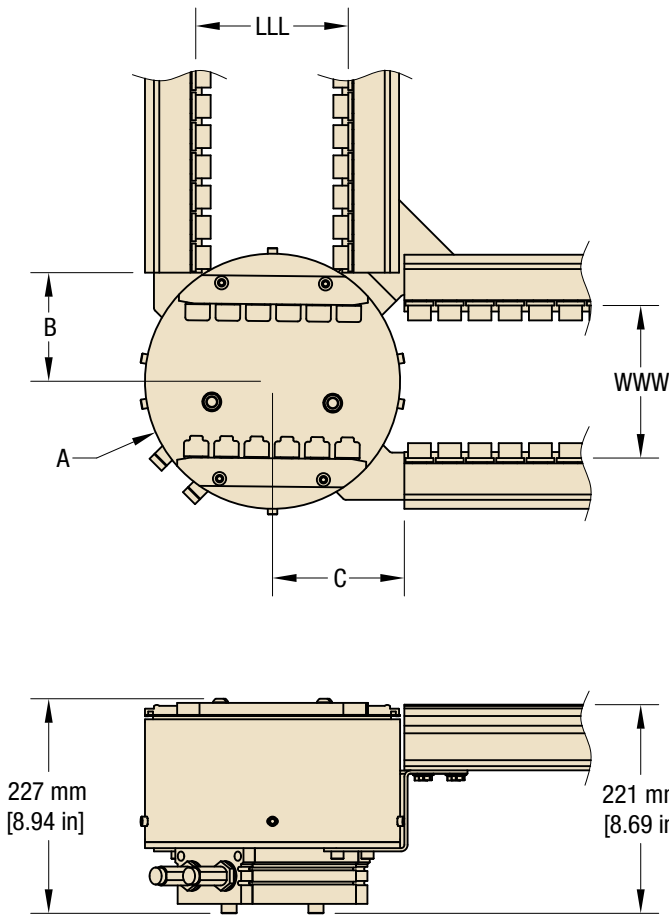

Turn and Transfer Conveyor				
Width	Length	A	B	C
160	160	270 mm (10.63 in)	115 mm (4.53 in)	140 mm (5.51 in)
	240	320 mm (12.60 in)	133 mm (5.24 in)	158 mm (6.22 in)
200	200	320 mm (12.60 in)	133 mm (5.24 in)	158 mm (6.22 in)
240	240	370 mm (14.57 in)	151 mm (5.94 in)	176 mm (6.93 in)
	320	420 mm (16.54 in)	168 mm (6.61 in)	193 mm (7.60 in)
280	280	420 mm (16.54 in)	168 mm (6.61 in)	193 mm (7.60 in)
320	320	470 mm (18.50 in)	186 mm (7.32 in)	211 mm (8.31 in)

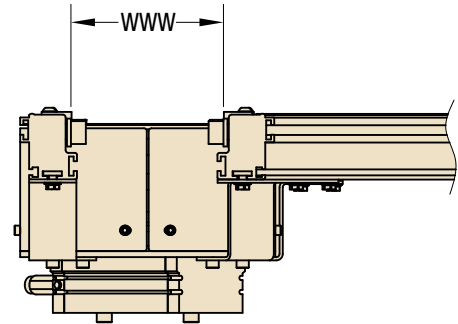

**ERT150: Turn and Transfer**

ER 3 Y M WWW - LLL AAA D S C - 2

- Turn: 2 = 2-way 3 = 3-way 4 = 4-way
- Controller Type: A = No Controller B = Controller with mount (for all motors)
- Speed: 1 = 87 rpm (10 mpm) 2 = 129 rpm (15 mpm) 3 = 176 rpm (20 mpm)  
4 = 215 rpm (25 mpm) 5 = 317 rpm (37 mpm)
- Direction: L = Left R = Right
- Angle: 090 = 90 Degree
- Conveyor Length Reference: (see combinations chart)
- Conveyor Width Reference: (see combinations chart)
- Documentation Language: M = US-English
- Corner: Y = Rotary Turn
- Conveyor Type: ERT150

Combinations	
WWW	LLL
160	160
	240
200	200
	160
240	240
	320
280	280
320	240
	320

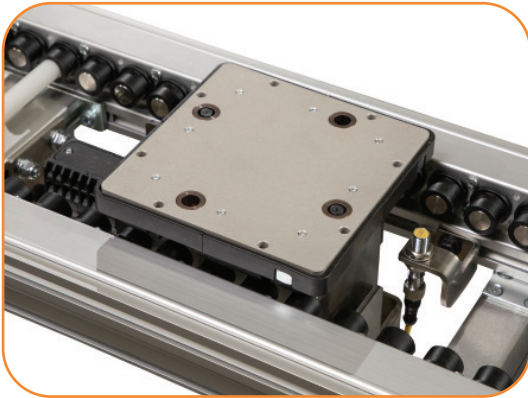
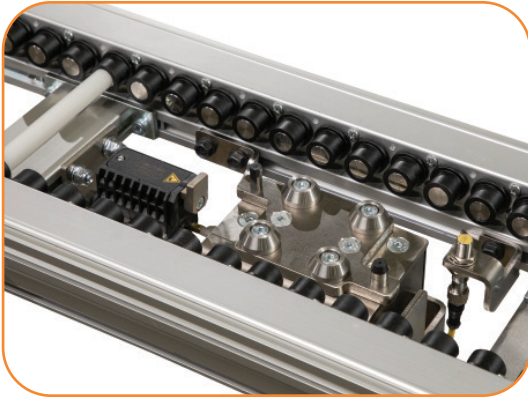

## Specifications

- 2 Models
  - Standard Unit for most accuracy capacity
  - Low Height Unit for over/under applications
- Lifts from center of conveyer
- Pallet sizes: see chart
- Lift Capacity: 45.5 kg (100 lbs)
- Repeatability:
  - Standard: +/- 0.13 mm (0.005 in)
  - Low Height: +/- 0.38 mm (0.015 in)
- Lift height is adjustable. Maximum lift height is 20 mm (0.79 in) above top of roller
- Includes adjustable bumper lift stroke
- 40 mm diameter pneumatic lift cylinder. Includes air fittings with integrated flow controls for ¼ inch push in air line. Solenoid valves and plumbing not provided
- Lift cylinder includes magnetic piston for position sensing. Sensors not provided. Compatible with 4 mm C-slot sensors.
- Requires cushioned or non-cushioned pallet stop. See page 25-27
- Optional guarding package available

### Pallet Sizes

		Length (mm)				
		160	200	240	280	320
Width (mm)	160	X		X		
	200		X			
	240	X		X		X
	280				X	
	320			X		X



**OPTIONAL:**  
**Guarding Package**



# LIFT AND LOCATE

## STANDARD UNIT

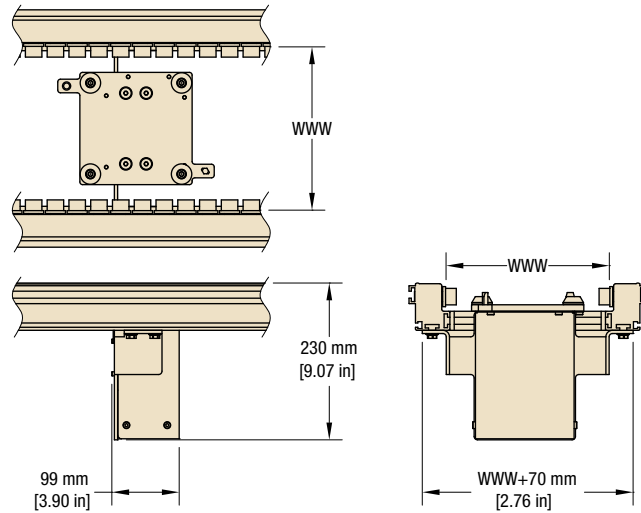

## LOW HEIGHT UNIT

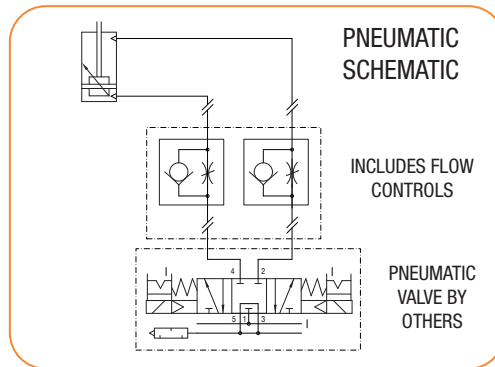
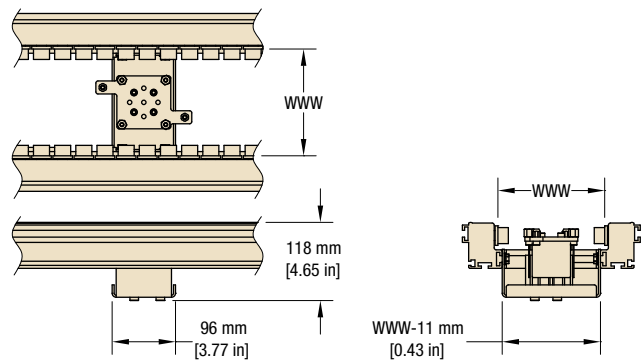

**ERT150: Lift and Locate**

ER 3 | L | M | WWW | - | LLL | C | N | G

- Guarding Included: **N** = No Guarding **G** = Guarding Included
- Pallet Sensor Option: **N** = No Sensor Bracket **B** = Bottom Sensor Bracket **S** = Side Sensor Bracket
- Stop Type: **C** = Cushioned **F** = Non-Cushioned **N** = None
- Conveyor Length Reference: **160 - 320** (See combination chart)
- Conveyor Width Reference: **160 - 320** (See combination chart)
- Documentation Language: **M** = US-English
- Conveyor Type: **L** = Standard Lift and Locate **H** = Low Height Lift and Locate

All combinations are valid except 160 mm width or length is not compatible with the bottom sensor bracket.

Combinations	
WWW	LLL
160	160
	240
200	200
	160
240	240
	320
280	280
320	240
	320

For detailed module spacing, see pages 41-42. For pneumatic specifications, see page 40.

**Note:** Due to the wide variety of drive setups and applications, point of installation guarding is the responsibility of the end user.  
**Note:** Dimensions = mm (in)

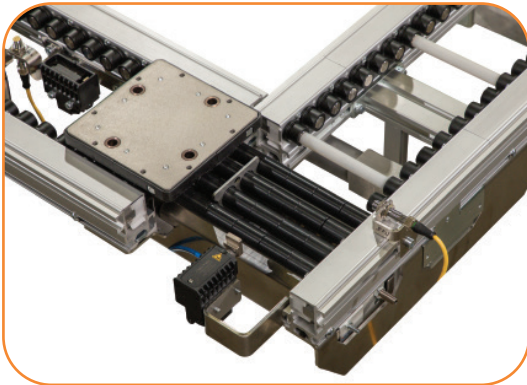
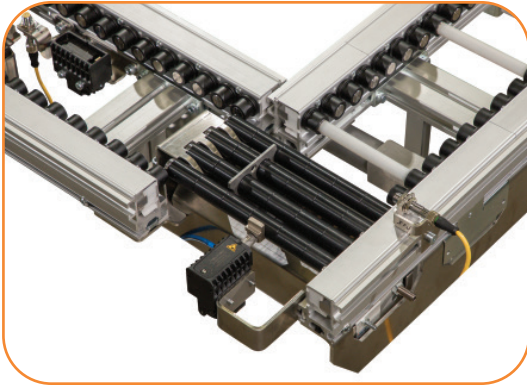

### Specifications

- Pneumatic pusher with integrated corner conveyor
- Pallet sizes: see chart
- Load capacity: up to 16 kg (35 lbs) per pallet
- Pallet pusher across transfer roller conveyor. No height change required.
- Includes ERT150 Series Transfer Conveyor
  - 24 mm (0.95 in) diameter rollers on 32 mm (1.26 in) centers
  - Load capacity: up to 16 kg (35 lbs) per pallet
  - Up to 37 m/min (121 ft/min)
  - Slip rollers
  - Brushless DC gearmotor and controller. See page 28-29 for specifications
- 20 mm diameter pneumatic pusher cylinder provided. Includes air fittings with integrated flow controls for ¼ inch push in air line. Solenoid valves and plumbing not provided
- Pusher cylinder includes magnetic piston for position sensing. Sensors not provided.

**Pallet Sizes**

		Length (mm)				
		160	200	240	280	320
Width (mm)	160	X		X		
	200		X			
	240	X		X		X
	280				X	
	320			X		X

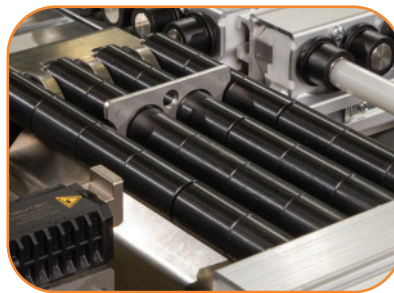

**STANDARD FEATURE:**  
**Break-Away Pusher Blade**  
for operator safety

# PALLET PUSHER

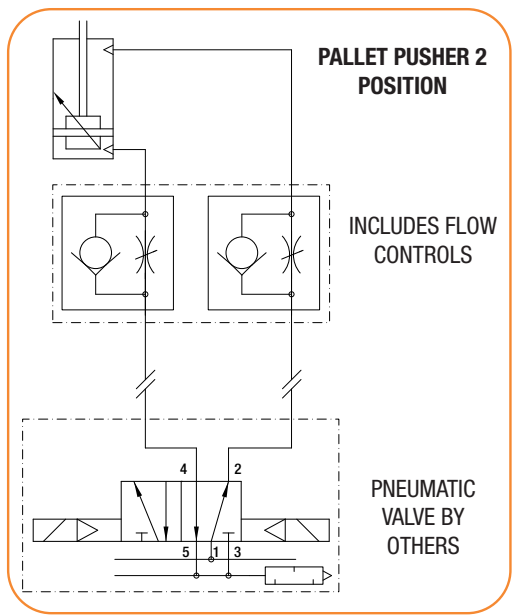
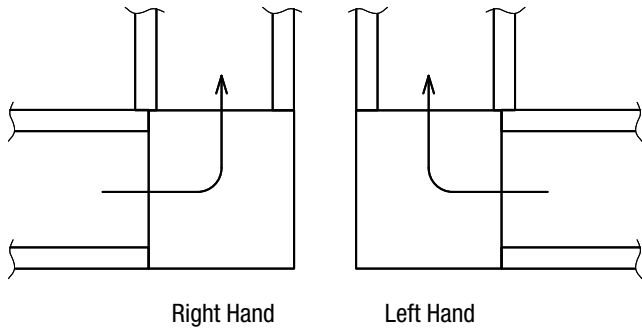
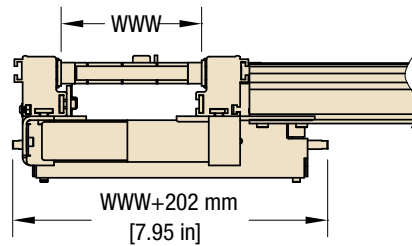
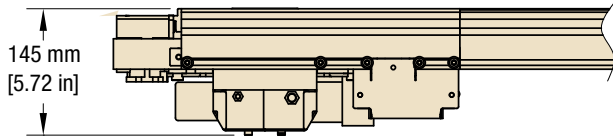
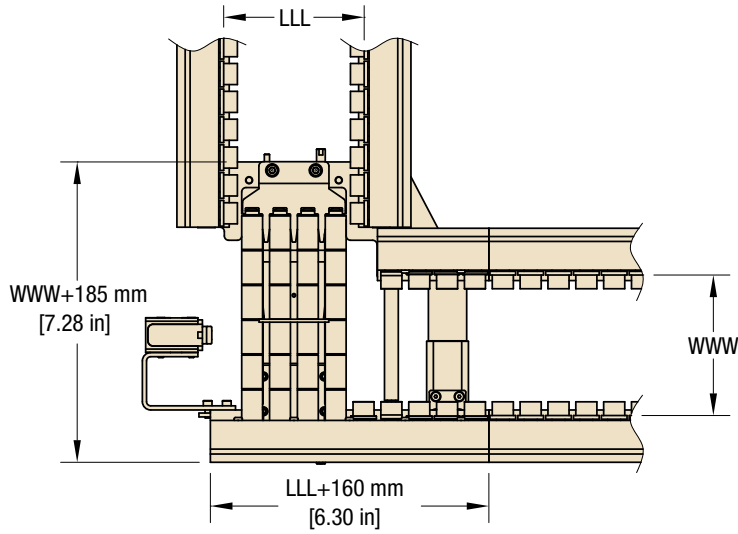

**ERT150: Pallet Pusher**

ER 3 D M WWW - LLL D S C N

- Pallet Sensor Option:**
  - N = No Sensor Bracket
  - S = Side Sensor Bracket
- Controller Type:**
  - A = No Controller
  - B = Controller with Mount Bracket
- Speed:**
  - 1 = 87 rpm (10 mpm)
  - 2 = 129 rpm (15 mpm)
  - 3 = 176 rpm (20 mpm)
  - 4 = 215 rpm (25 mpm)
  - 5 = 317 rpm (37 mpm)
- Direction:** L = Left R = Right
- Conveyor Length Reference:** 160 - 320 (See combination chart)
- Conveyor Width Reference:** 160 - 320 (See combination chart)
- Documentation Language:** M = US-English
- Conveyor Type:** D = Pallet Pusher

Combinations	
WWW	LLL
160	160
	240
200	200
	160
240	240
	320
280	280
	240
320	320

PNEUMATIC SCHEMATICS

For detailed module spacing, pages 41-42. For pneumatic specifications, see page 40.

**Note:** Due to the wide variety of drive setups and applications, point of installation guarding is the responsibility of the end user.  
**Note:** Dimensions = mm (in)

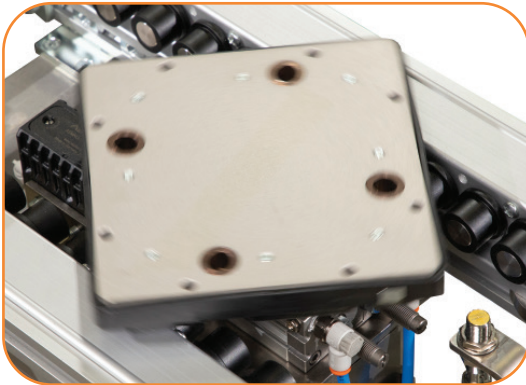
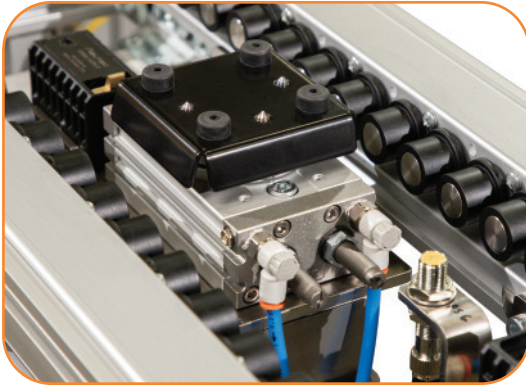

## Specifications

- Pneumatic lifts from center of conveyor
- Pneumatic rotation with configurable 90 or 180 degree position
- Includes break-away magnetic coupled rotation plate for product safety
- Pallet sizes: see chart
- Rotation angle: 90 or 180 degrees
  - 90 degrees must be square pallets
  - Rectangular pallet sizes must be 180 degrees
- Lift Capacity: up to 16 kg (35 lbs)
- 40 mm diameter pneumatic lift cylinder. Includes air fittings with integrated flow controls for ¼ inch push in air line. Solenoid valves and plumbing not provided
- 21 mm diameter pneumatic rotary actuator
- Lift cylinder includes magnetic piston for position sensing. Sensors not provided. Compatible with 4 mm C-slot sensors.
- Slip Roller base conveyors requires cushioned or non-cushioned pallet stop. See page 25-27
- Optional guarding package available

**Pallet Sizes**

		Length (mm)				
		160	200	240	280	320
Width (mm)	160	X		X		
	200		X			
	240	X		X		X
	280				X	
	320			X		X

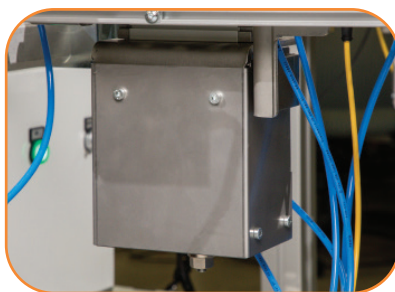

**OPTIONAL:**  
Guarding Package



**STANDARD FEATURE:**  
Breakaway Top Plate  
for operator safety

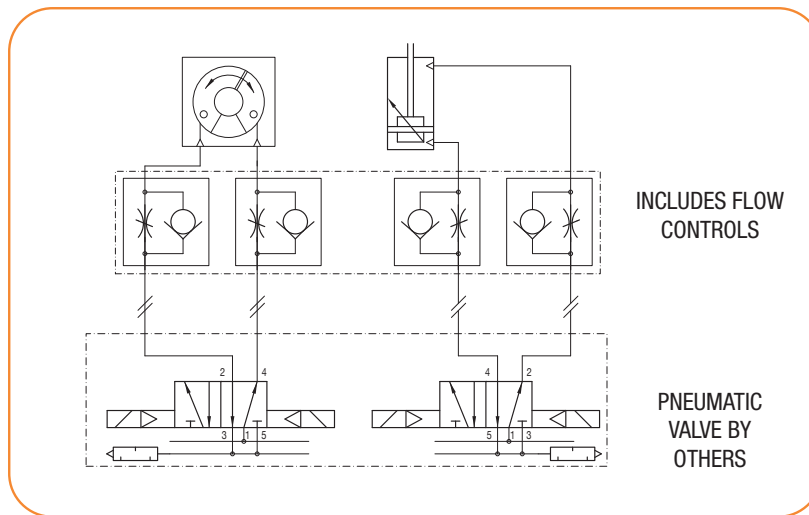
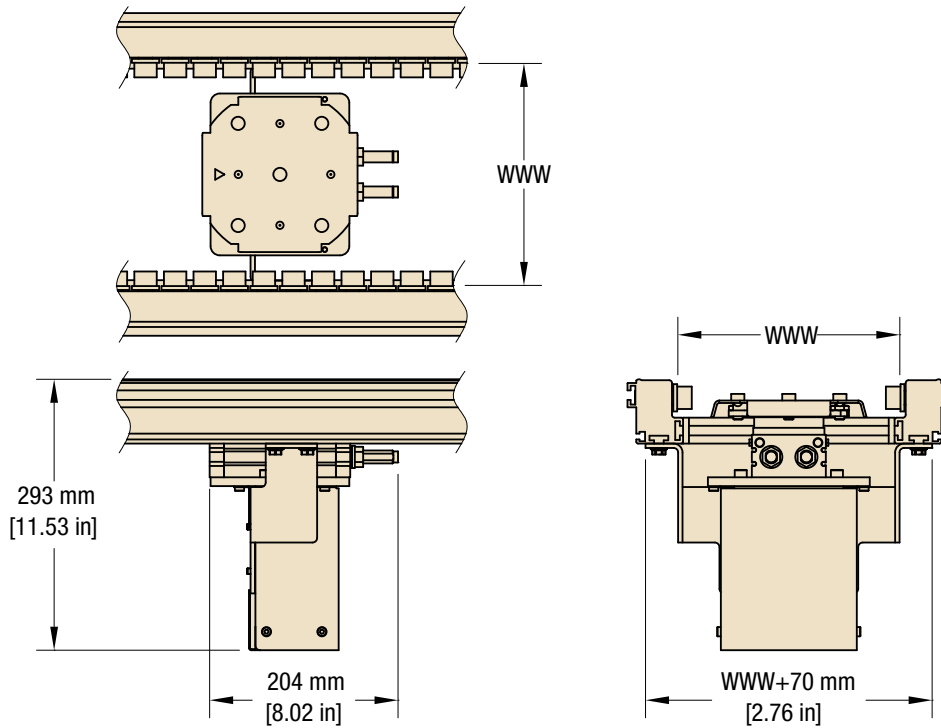

PNEUMATIC SCHEMATIC

**ERT150: Lift and Rotate**

ER 3	R	M	WWW	-	LLL	AAA	C	N	G

**Guarding Included:** N = No Guarding G = Guarding Included  
**Pallet Sensor Option:** N = No Sensor Bracket B = Bottom Sensor Bracket  
**Stop Type:** C = Cushioned F = Non-Cushioned N = None  
**Angle:** 090 = 90 Degree 180 = 180 Degree  
**Conveyor Length Reference:** 160 - 320 (See combination chart)  
**Conveyor Width Reference:** 160 - 320 (See combination chart)  
**Documentation Language:** M = US-English  
**Conveyor Type:** R = Lift and Rotate

**Combinations**

WWW	LLL
160	160
	240
200	200
	160
240	240
	320
280	280
	240
320	240
	320

Only square combinations are valid for 90 degree.

For detailed module spacing, pages 41-42. For pneumatic specifications, see page 40.

**Note:** Due to the wide variety of drive setups and applications, point of installation guarding is the responsibility of the end user.  
**Note:** Dimensions = mm (in)

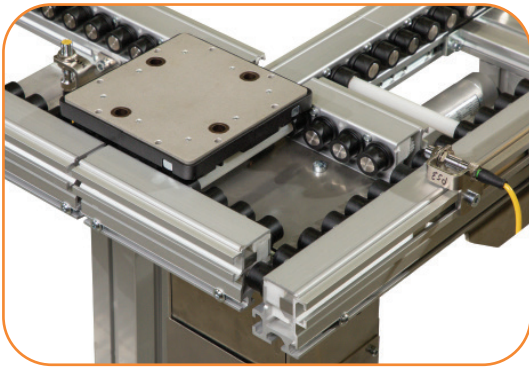
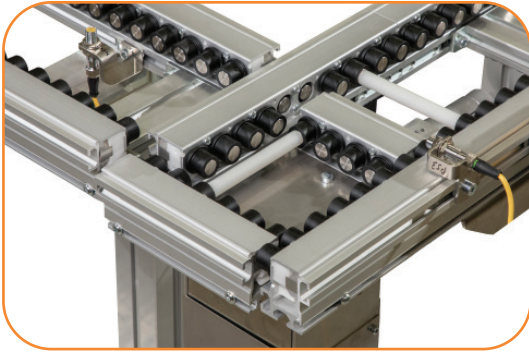

## Specifications

- 2 position lift and transfer
  - Up position transfers pallet on/off transverse conveyor
  - Down position lowers the transfer conveyor below feed conveyor
  - Indexing motor on feed conveyor is used to position incoming pallet for sending applications, eliminating pallet stops
- Pallet sizes: see chart
- Lift Capacity: up to 18 kg (40 lbs)
- Pallet transfers over conveyor side frame. 10 mm (0.40 in) height change required
- Includes ERT150 Series Transfer Conveyor
  - 24 mm (0.95 in) diameter rollers on 32 mm (1.26 in) centers
  - Load capacity: up to 18.2 kg (40 lbs) per pallet
  - Up to 37 m/min (121 ft/min)
  - Driven rollers
  - Brushless DC gearmotor and controller. See page 28-29 for specifications
  - Bi-directional and reversing
- Lift and transfer 240 mm wide and smaller include infeed conveyor. See page 24 for detail layouts.
- 40 mm diameter pneumatic lift cylinder. Includes air fittings with integrated flow controls for ¼ inch push in air line. Solenoid valves and plumbing not provided
- Lift cylinder includes magnetic piston for position sensing. Sensors not provided. Compatible with 4 mm C-slot sensors.
- Optional guarding package available

**Pallet Sizes**

		Length (mm)				
		160	200	240	280	320
Width (mm)	160	X		X		
	200		X			
	240	X		X		X
	280				X	
	320			X		X



**OPTIONAL:**

**Guarding Package and Pallet Sensor**

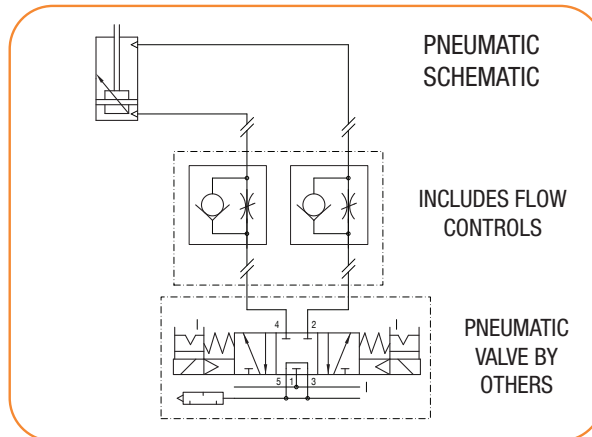
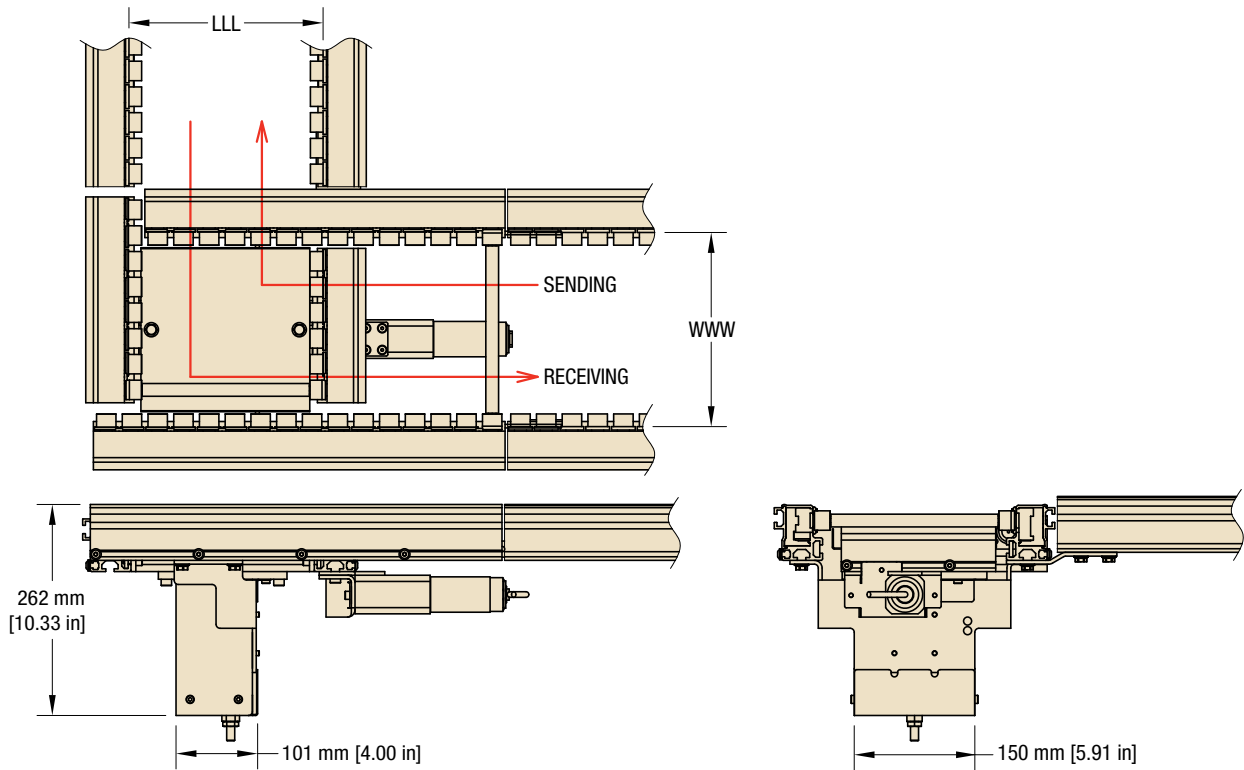

**ERT150: Lift and Transfer**

ER 3 T M WWW - LLL F D C N G S C

- Controller Type: A = No Controller B = Controller with Mount Bracket
- Speed: 1 = 87 rpm (10 mpm) 2 = 129 rpm (15 mpm) 3 = 176 rpm (20 mpm)  
4 = 215 rpm (25 mpm) 5 = 317 rpm (37 mpm)
- Guarding Included: N = No Guarding G = Guarding Included
- Pallet Sensor Option: N = No Sensor Bracket S = Side Sensor Bracket (for sending)  
R = Rocker Sensor Bracket (for receiving)
- Stop Type: C = Cushioned F = Fixed Non-cushioned N = None
- Direction: S = Sending R = Receiving
- Flow Option: E = End Stop P = Pass Thru
- Conveyor Length Reference: 160 - 320 (See combination chart)
- Conveyor Width Reference: 160 - 320 (See combination chart)
- Documentation Language: M = US-English
- Conveyor Type: T = Lift and Transfer

**Combinations**

WWW	LLL
160	160
	240
200	200
	160
240	240
	320
280	280
	240
320	240
	320

For detailed module spacing, pages 41-42. For pneumatic specifications, see page 40.

Note: Due to the wide variety of drive setups and applications, point of installation guarding is the responsibility of the end user.  
Note: Dimensions = mm (in)

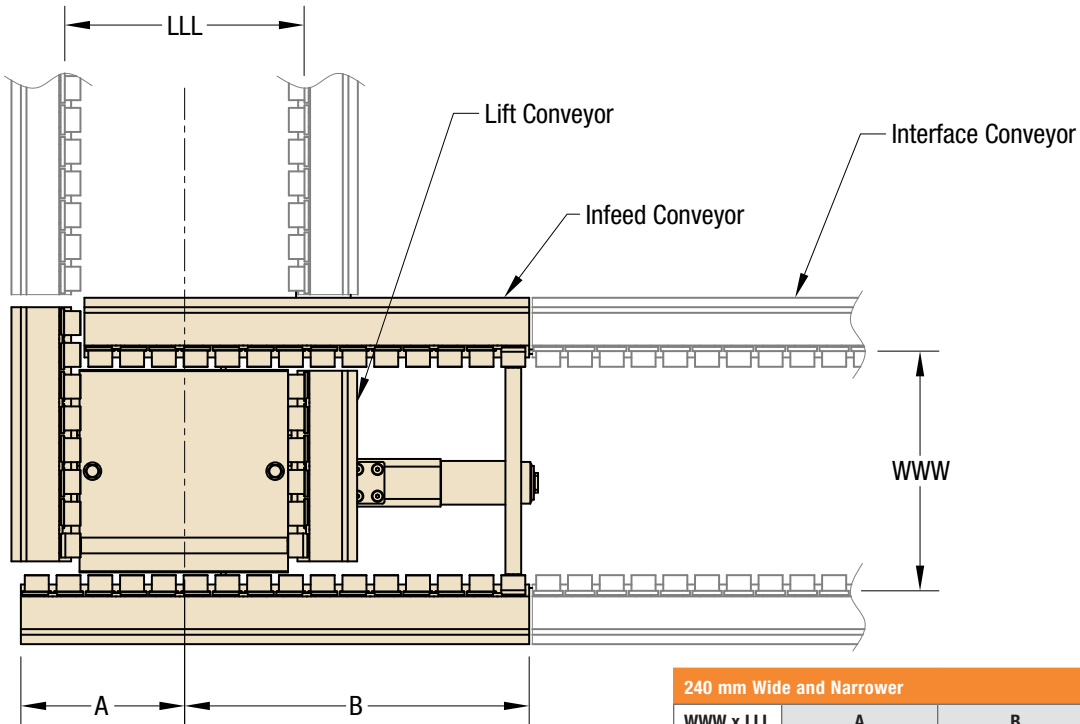

**240 mm Wide and Narrower**

240 mm Wide and Narrower		
WWW x LLL	A	B
160 x 160	125 mm (4.91 in)	259 mm (10.21 in)
160 x 240	153 mm (6.01 in)	359 mm (14.15 in)
200 x 200	145 mm (5.69 in)	303 mm (11.94 in)
240 x 160	125 mm (4.91 in)	323 mm (12.73 in)
240 x 240	165 mm (6.48 in)	347 mm (13.67 in)

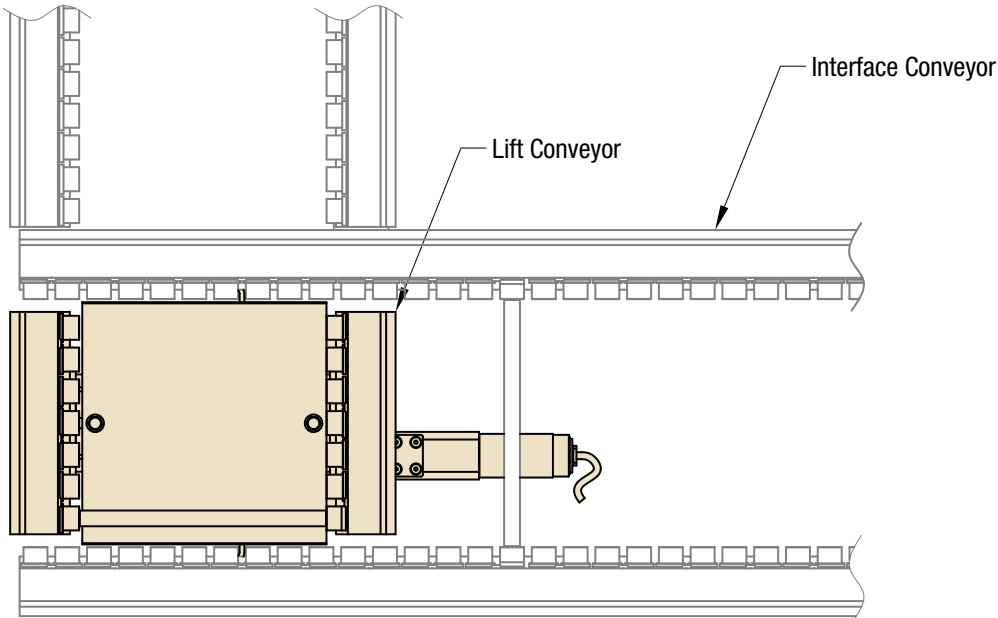

**280 mm Wide and Wider**



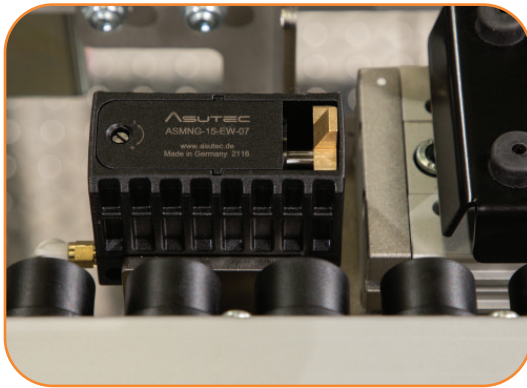

## Light Load Pallet Stop – Cushioned

Cushioned pallet stop for traffic control. Stops one or more pallets at the specified location on the conveyor. Cushioned deceleration of the first pallet into the stopped location, guarding against vibration of sensitive payloads. Accumulated pallets are not cushioned. Air pressure disengages the stop allowing pallets to pass until the pressure is released. A spring return re-engages the pallet stop and resets the cushion.

### Specifications

- Maximum Load: 15 kg (33 lbs) accumulated
- Pneumatically activated, spring return
- Stops the pallet on the leading or trailing edge
- Mounts on the inside of the conveyor rail
- Airline can be mounted on the front or back of the stop
- Includes: stop, mounting hardware, and fittings for 6.3 mm (1/4 in) push in air line
- Optional vertical or side mounted sensor bracket. See page 33

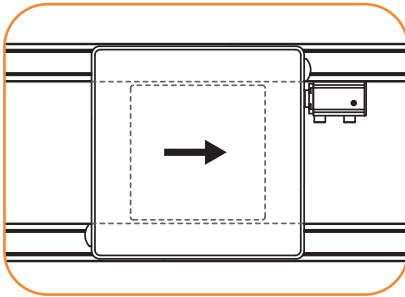

Stop Located After Pallet

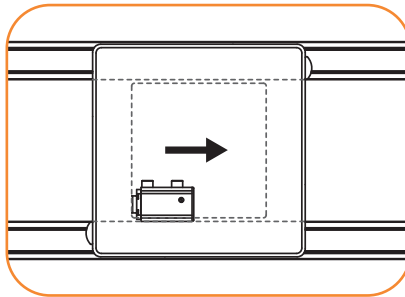

Stop Located Inside Pallet

#### ERT150: Pallet Stops

ER 3 S M - X N N  
 - Sensor Option: N = No Sensor Bracket B = bottom sensor bracket S = Side Sensor Bracket  
 - Stop Type: C = Cushioned Pallet Type F = Non-cushioned Pallet Type  
 - Load Capacity: L = Light S = Standard  
 - Documentation Language: M = US-English  
 - Pallet: S = Stop

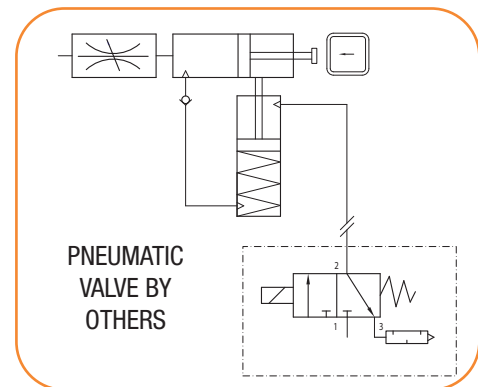
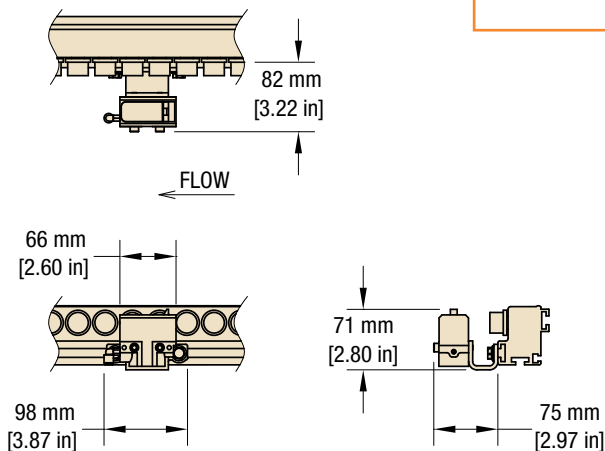
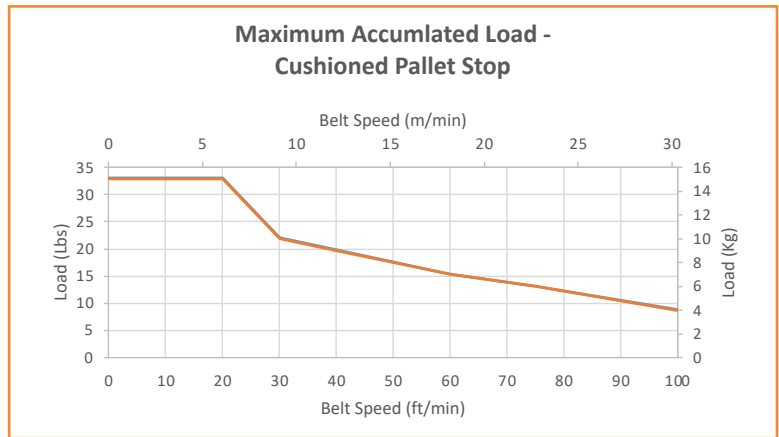

PNEUMATIC VALVE BY OTHERS

PNEUMATIC SCHEMATIC

For pneumatic specifications, see page 40.

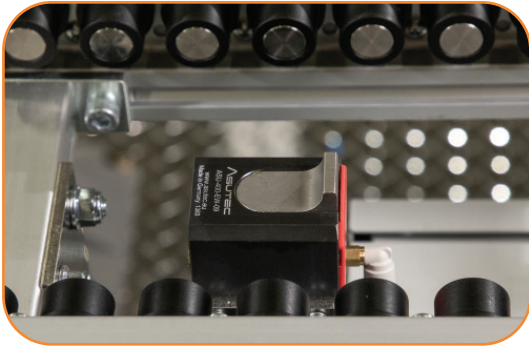

## Standard Load Pallet Stop – Non-cushioned

Non-cushioned pallet stop for traffic control. Stops one or more pallets at the specified location on the conveyor. Air pressure disengages the stop allowing pallets to pass until the pressure is released. A spring return re-engages the pallet stop.

### Specifications

- Maximum Load: 68 kg (150 lbs) accumulated
- Pneumatically activated, spring return
- Mounts on the inside of the conveyor rail
- Airline can be mounted on the front or back of the stop
- Includes: stop, mounting hardware, and fittings for 6.3 mm (1/4 in) push in air line
- Optional vertical or side mounted sensor bracket. See page 33

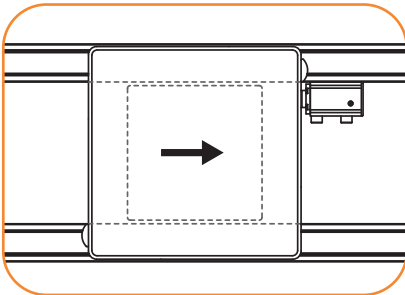

**Stop Located After Pallet**

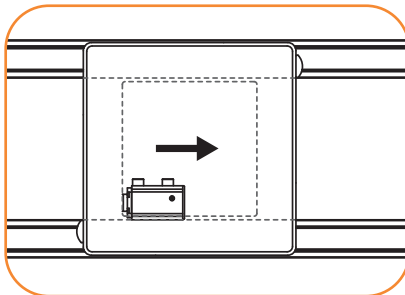

**Stop Located Inside Pallet**

#### ERT150: Pallet Stops

ER 3 S M - X N N  
 - Sensor Option: N = No Sensor Bracket B = bottom sensor bracket S = Side Sensor Bracket  
 - Stop Type: C = Cushioned Pallet Type F = Non-cushioned Pallet Type  
 - Load Capacity: L = Light S = Standard  
 - Documentation Language: M = US-English  
 - Pallet: S = Stop

### Maximum Accumulated Load - Non-cushioned Pallet Stop

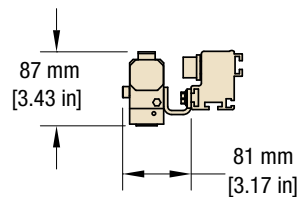
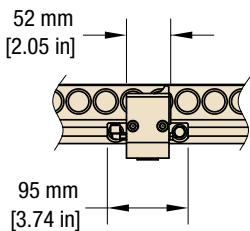
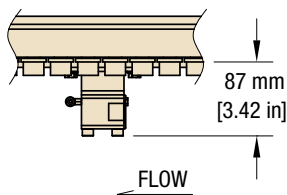
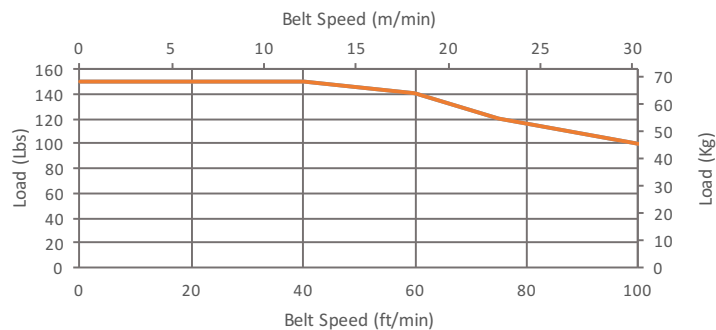

**Note:** Due to the wide variety of drive setups and applications, point of installation guarding is the responsibility of the end user. **Note:** Dimensions = mm (in)

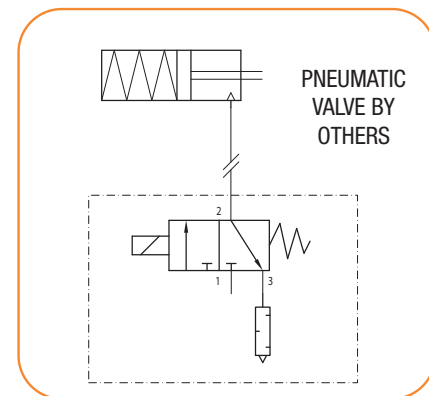

**PNEUMATIC SCHEMATIC**

For pneumatic specifications, see page 40.



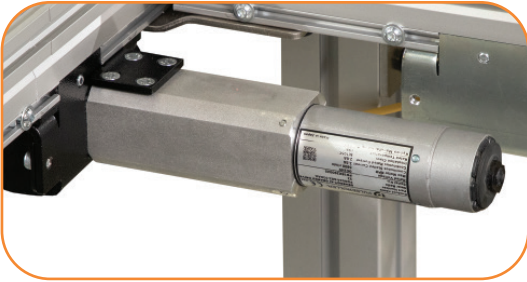

### Specifications

- Brushless DC Gearmotor
- 50 watt
- 24 VDC
- IP 54 ingress rating
- Aluminum body, steel shaft
- Certifications
  - ETL/UL certified
  - CE certified
  - RoHS and REACH compliant
- Temperature rating: -10° to 40° C (14° to 104° F)
- M8-4 Pin connector with 1 m long cable

Part Number*	Maximum Speed m/min (ft/min)	Gear Ratio	Shaft Speed Rev/min	Rated Torque Nm (in-lb)	Starting Torque Nm (in-lb)	Rated Current amps	Starting current amps
826-984	10.3 (33.7)	67.22	8.6 to 86.7	4.4 (39.1)	24 (215)	2.5	3.0
826-985	15.2 (50)	45	12.8 to 129	2.9 (26.2)	16 (145)	2.5	3.0
826-986	20.8 (68.2)	33	17.5 to 176	2.2 (19.2)	12 (106)	2.5	3.0
826-987	25.4 (83.3)	27	21.3 to 215	1.8 (15.7)	9.8 (87)	2.5	3.0
826-988	37.4 (122.8)	18.33	31.5 to 317	1.2 (10.6)	6.7 (59)	2.5	3.0

\*Note: Gearmotor is provided with conveyor part number and not required to be ordered separately.

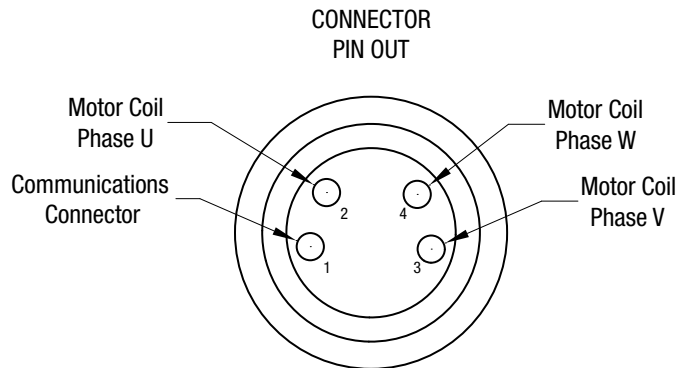
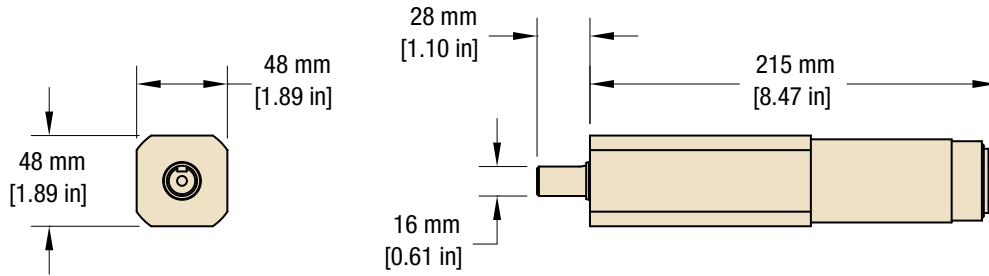

Note: Dimensions = mm (in)



### Electrical Specifications

Voltage Range	18-28 VDC
Rated Current	5.2 amps, for 2 gearmotors
Starting Current	6.0 amps, for 2 gearmotors
Operating ambient temperature	-10 to 40 C (14 to 104F)

Part Number	400396
-------------	--------

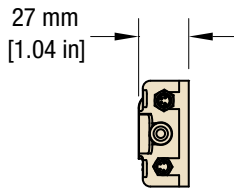
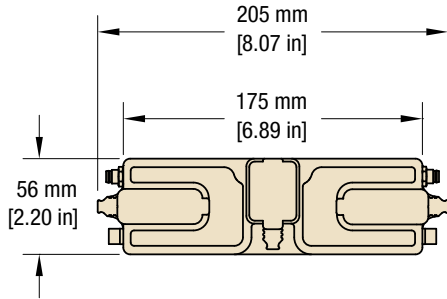

INTERFACE CONNECTOR  
PIN OUT

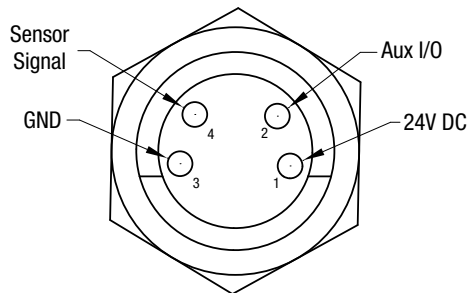

## Specifications

- Brushless DC Ethernet motor control
- Control can be used as motor drive and/or remote I/O
- Controls up to 2 gearmotors
- Controls up to 4 inputs
- Built in zero pressure accumulation logic for zoning applications
- ConveyLINX software is used to set up controller and adjust control parameters\*
- IP 54 ingress rating
- Certifications
  - UL recognized to UL/eUL standard 61800-5-1
  - CAN.CSA to standards: C22.2 NO.61010-1
  - CE certified
  - RoHS and REACH compliant
- Connectivity
  - Ethernet IP
  - Modbus TCP
  - PROFINET

### ConveyLINX Software\*

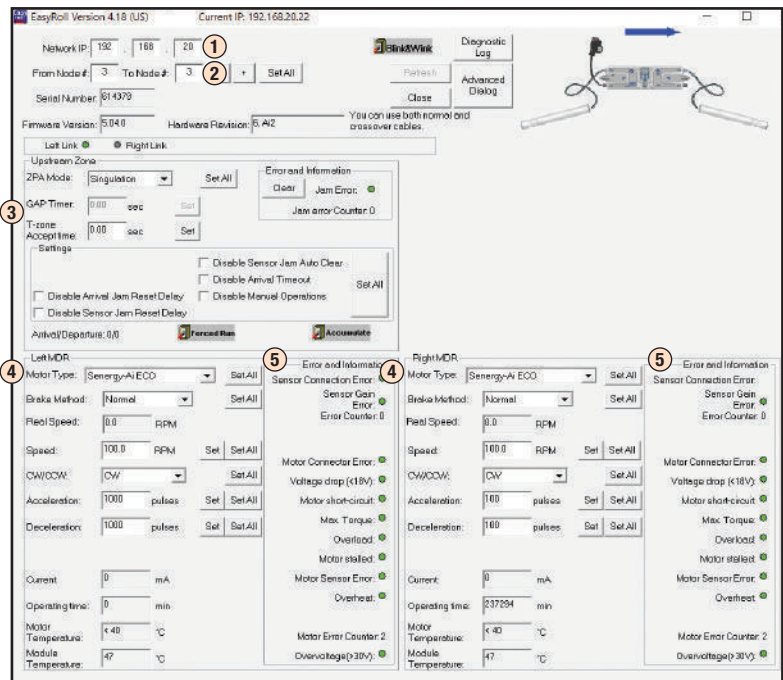

1. Configure Network IP
2. Configure Nodes on Network
3. Upstream / Downstream Gearmotor, select mode
4. Upstream / Downstream gearmotor, select motor speed, acceleration/ deceleration, etc.
5. Error Indicators for connection and performance

\*ConveyLINX Software provided by Pulse Roller, see [www.pulseroller.com](http://www.pulseroller.com) for details.

**Note:** Due to the wide variety of drive setups and applications, point of installation guarding is the responsibility of the end user.

**Note:** Dimensions = mm (in)

**Wiring Diagram:**

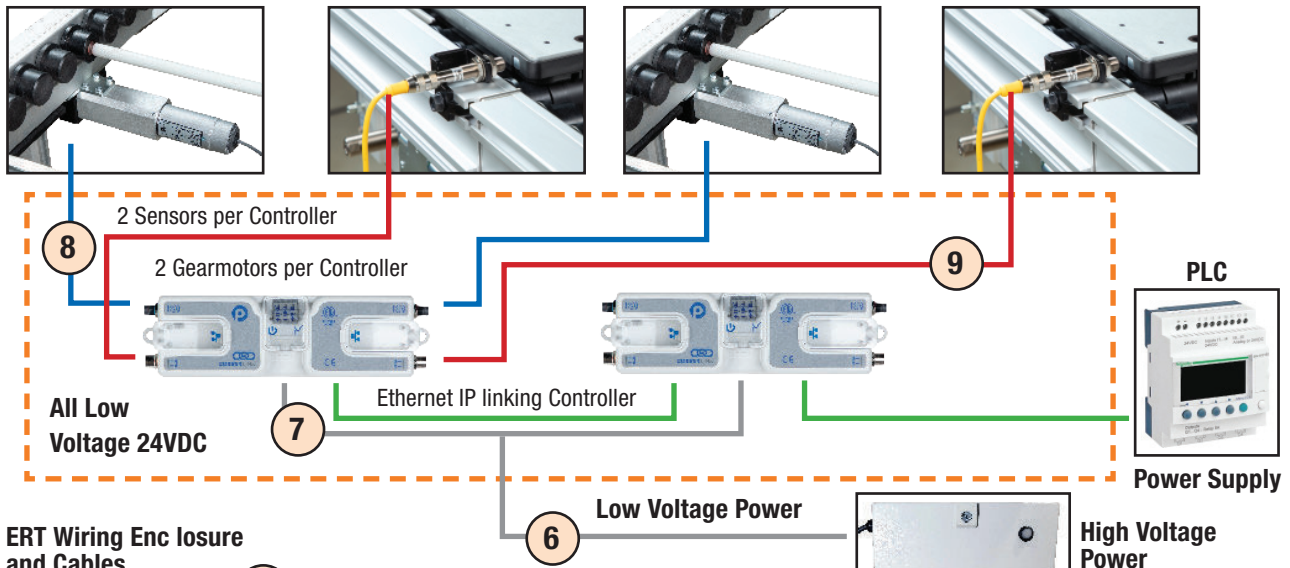

**ERT Wiring Enclosure and Cables**

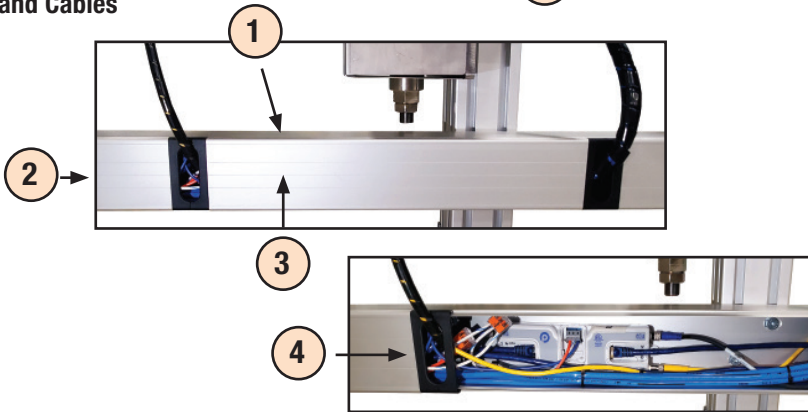

**Specifications**

- Standard enclosures and wiring to support efficient use of low voltage ERT gearmotors and sensors
- All wires are quick disconnect
- All enclosures are aluminum for ease of cutting in the field
- Components are ordered individually

Item	Part Number	Description	Specification
1	ERTW1-CE3000	ERT Motor Controller Enclosure, 80 mm x 80 mm x 3000 mm long, Aluminum	Aluminum Extruded Enclosure, requires customer to cut to length and add mounting holes
2	ERTW1-ECX	ERT Motor Controller Enclosure End Cap. Where X = 1 for closed, X = 2 for with hole for wiring pass through	Plastic end cap for closing motor controller closure. Includes mounting screws
3	ERTW1-CV3000	ERT Motor Controller Enclosure Cover 3000 mm long, Aluminum	Aluminum Extruded Cover, requires customer to cut to length. Snaps into main enclosure for tight fit
4	ERTW1-CBE1	ERT Motor Controller Enclosure Cable Entry Single Hole	Plastic 2-piece cover providing cable entry to enclosure
5	ERTW1-MBXXXX	ERT Motor Controller Enclosure Mounting Bracket Where XXXX = length of support arm. 0100, 0200, 0300, 0400 mm long	Mounting bracket including hardware. Mounts to conveyor cross members and automation module support arms Maximum distance between supports = 2000 mm.
6	ERTCB1-PCXXXX	ERT DC Power Supply to Enclosure Cable XXXX mm long. Where XXXX = length in mm. 1000, 2000, 3000, 4000 mm length available.	12 Ga. 3 wire cable. Includes re-usable clamp style wire connectors to splice up to 4 controllers
7	ERTCB1-LCXXXX	ERT Controller Linking Cable XXXX mm long. Where XXXX = length in mm. 1000, 2000, 3000 mm length available.	8 Ga. 3 wire cable
8	ERTCB1-MCXXXX	ERT Controller to Motor Extension Cable XXXX mm long. Where XXXX = length in mm. 2000, 3000 mm length available.	24 Ga. 4 wire cable. Includes M-8 male/female quick disconnect connector on both ends of cable
9	ERTCB1-SCXXXX	ERT Controller to Sensor Cable XXXX mm long. Where XXXX = length in mm. 2000, 3000, 4000 mm length available.	24 Ga. 4 wire cable. Includes M-8 male/female disconnect connector on both ends of cable

## Multiple Conveyor Power Supply



Outside



Inside

### Specifications

- Provides 24 VDC power to gearmotor controllers
- 20 AMP output can power up to 4 controllers
- Recommended to be placed near controller on conveyor line
- IP66 painted steel enclosure
- Panel mounted pull-to-release on/off button with indicator light
- See page 30 for low voltage cable to controllers
- High voltage wiring by customer

Part Number	Input Volts	Input Phase	Input H <sub>3</sub>	Input Amps	Output Volts	Output Amps
ERTPS1-112D-20A	110	1	60	4.5	24 VDC	20
ERTPS1-122D-20A	220	1	60	2.3	24 VDC	20
ERTPS1-232D-20A	230	3	60	2.2	24 VDC	20
ERTPS1-432D-20A	460	3	60	1.1	24 VDC	20

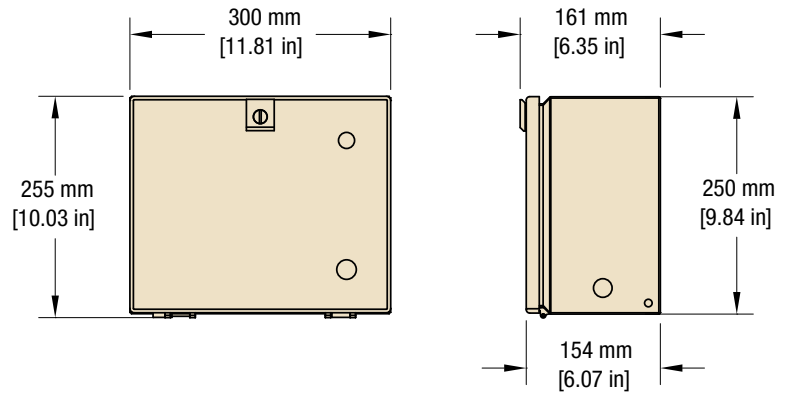

## Single Conveyor Power Supply



### Specifications

- Provides 24 VDC power to gearmotor controller
- 5 AMP output can power one controller
- 115V, 1 Phase, 60 hz input
- RoHS, REACH certified
- UL, CUL and CE approved
- Black plastic enclosure

Part Number	400386
-------------	--------

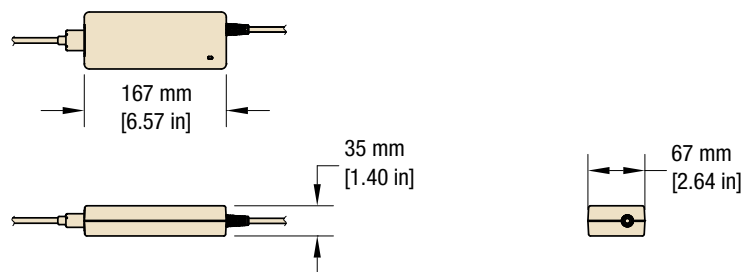



### Fixed Height Support Stands

- 300 mm (11.81 in) minimum TOB height
- 2580 mm (101.6 in) maximum TOB height
- Aluminum construction with T-slot mounting for bolt on accessories and structure
- Adjustment range is  $\pm 40$  mm (1.57 in)

Stand Height Chart			
<b>Stand Height</b>	260 – 340 mm (10.2 – 13.4 in)	40 mm (1.57 in) increments up to...	2540 – 2620 mm (100 - 103 in)
<b>Part Number Reference</b>	02600340	0040 increments up to...	25402620

**ERT150: Fixed Height Support Stands**

ER 3 P M - L L L L U U U U F

- Footings: F = Fixed Foot
- Upper Height to TOB (mm)
- Lower Height to TOB (mm)
- Documentation Language: M = US-English
- Post Standard: P

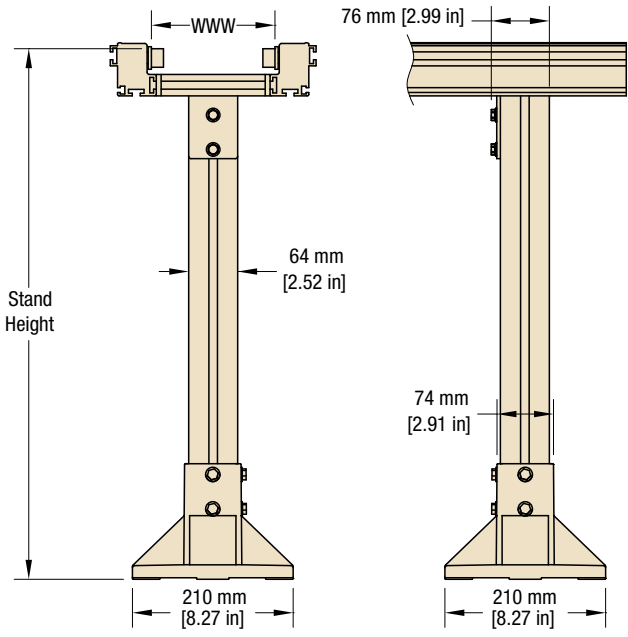

**Note:** Due to the wide variety of conveyor and stand options along with possible configurations, stability of the final setup is the responsibility of the end user.  
**Note:** Due to the wide variety of drive setups and applications, point of installation guarding is the responsibility of the end user. **Note:** Dimensions = mm (in)

### Conveyor Tie Bracket

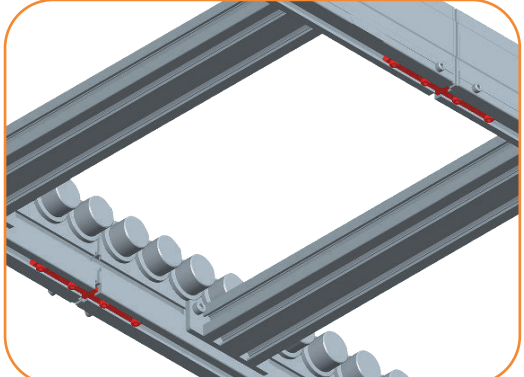

### Specifications

- Tie bracket for connecting conveyors in-line
- Can be used in bottom or inside T-slot.  
Do not use with T-slot cover
- Includes a pair of tie plate assemblies
- Includes all mounting hardware

<b>Part Number</b>	206519
--------------------	--------

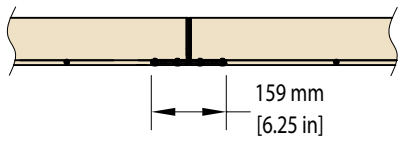



### Pallet Sensor Bracket, Bottom Sensing



#### Specifications

- Standard mounting for 12 mm barrel proximity sensors
- Sensor faces upward, sensing pallet pick-up on the bottom of pallet
- Requires a minimum of 25 mm (1 in) long threaded portion on sensor
- Includes all mounting hardware
- Proximity sensor with 4 mm minimum sensory range recommended

Part Number	400474-RH
-------------	-----------

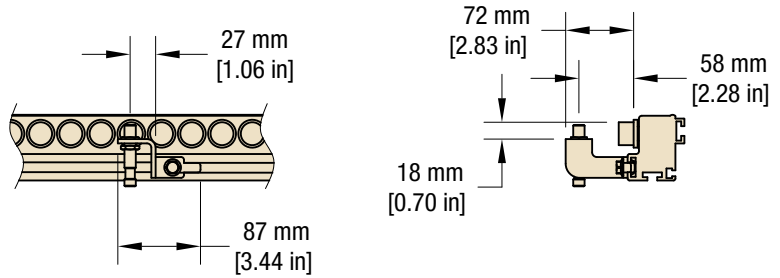

### Pallet Sensor Bracket, Side Sensing

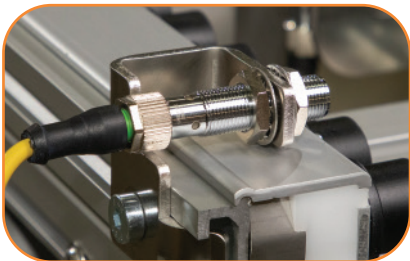

#### Specifications

- Standard mounting for 12 mm barrel proximity sensors
- Sensor faces inward, sensing pallet pick-up on outside of pallet
- Requires a minimum of 25 mm (1 in) long threaded portion on sensor
- Includes all mounting hardware
- Proximity sensor with 4 mm minimum sensory range recommended

Part Number	400470
-------------	--------

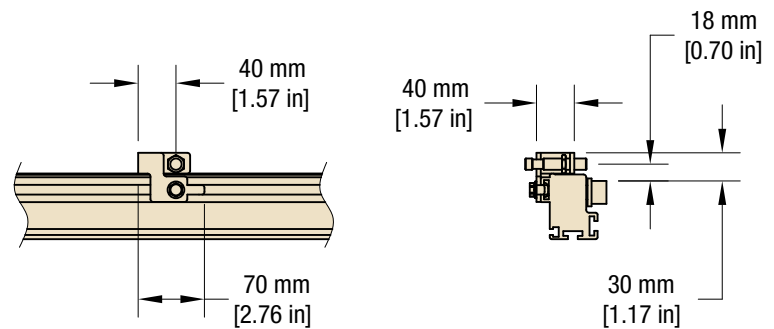
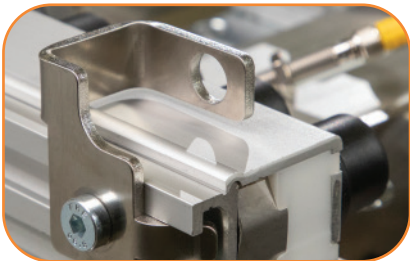

## T-slot Accessories

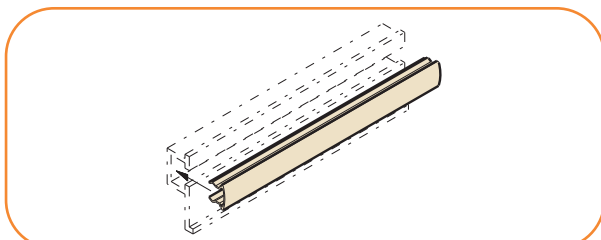
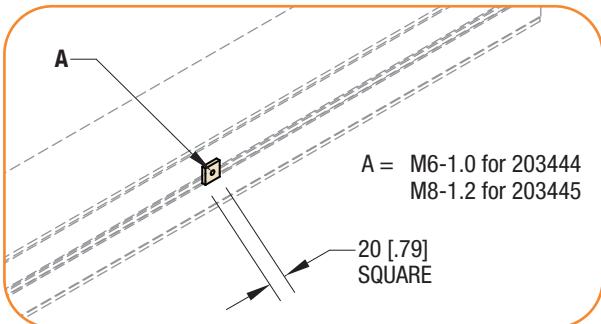
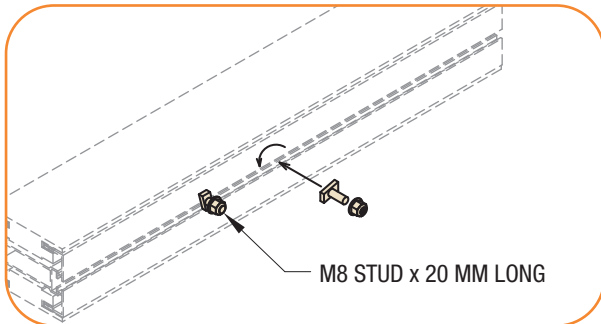
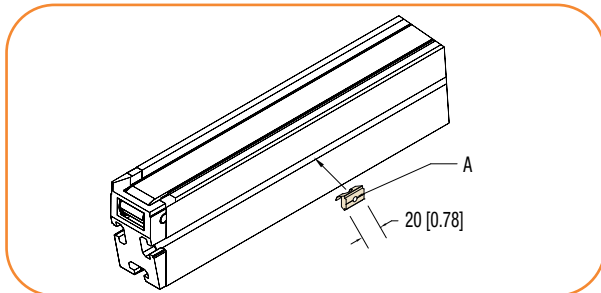
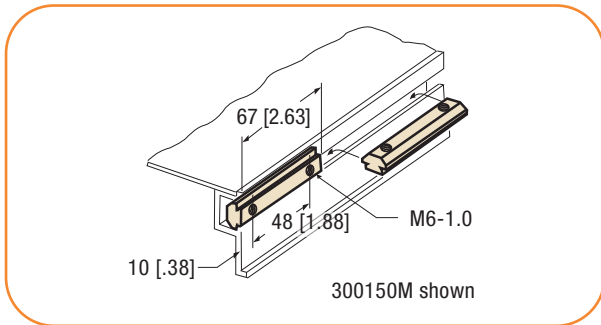

## T-Bars

- Mounts in T-slot to attach heavy accessories
- Fits conveyor and stands

Part Number	639971M (1 hole T-bar, M6-1.0, .75 in long) 202390M (1 hole T-bar, M8-1.25, .63 in long) 643874M (0.75 in centers, 2 hole T-bar, M6-1.0, 1.5 in long) 200626M (0.875 in centers, 2 hole T-bar, M6-1.0, 1.62 in long) 200830M (1.0 in centers, 2 hole T-bar, M6-1.0, 1.75" long) 639717M (1.25 in centers, 2 hole T-bar, M6-1.0, 2.0" long) 300150M (1.875 in centers, 2 hole T-bar, M6-1.0, 2.62 in long) 300536M (2.125 in centers, 2 hole T-bar, M6-1.0, 2.88 in long)
-------------	---

## Spring Nuts

- For mounting accessories to conveyor
- Spring retains position in T-slot
- 20 mm (0.78 in) long

Part Number	205504 M4 x 0.7 205505 M5 x 0.8 205506 M6 x 1.0 205508 M8 x 1.25
-------------	---

## T-Bolt Hardware

- For mounting accessories to conveyor
- Twist in T-Bolt for mounting accessories
- M8-1.25 male threaded post
- (2) lengths available; 20 mm long and 35 mm long
- 20 mm long used to mount up to 0.25 in plate thickness
- 35 mm long used to mount up to 0.85 in plate thickness
- Provided in a package of 5 T-Bolts and flanged locknuts

Part Number	203446 (20 mm long) 203447 (35 mm long)
-------------	--

## Slide In Square Nuts

- For mounting accessories to conveyor
- Must be slid in at section break
- (2) thread sizes available: M6-1.0 or M8-1.25
- Provided in a package of 5 nuts

Part Number	203444 (M6-1.0) 203445 (M8-1.25)
-------------	-------------------------------------

## T-Slot Cover

- Snaps into conveyor and aluminum stand T-slots
- Black plastic extrusion
- Can be trimmed to fit

Part Number	645656P (Per 305 mm (1 ft) of length)
-------------	---------------------------------------

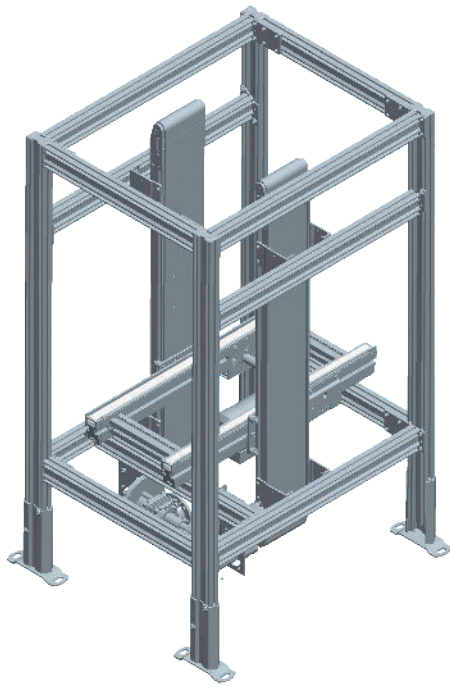

### Vertical Transfer Unit (Elevator)

Vertical Transfer Units raise or lower a pallet between two different levels allowing for over/under layouts or transferring pallets over aisles

- Includes Precision Move conveyor to shuttle pallets in and out of the Vertical Transfer Unit
- Transfers standard and custom pallet sizes
- Up to 91 kg (200 lbs) lift capacity
- Minimum Height TOB: 305 mm (12 in)
- Maximum height TOB 3050 mm (120 in)
- Transfer one or more pallet(s) per cycle
- AC VFD rated gearmotor driven lift and shuttle
- Includes Lexan guarding
- Includes proximity sensor brackets for pallet and lift position detection
- Available as a complete package including automation controls

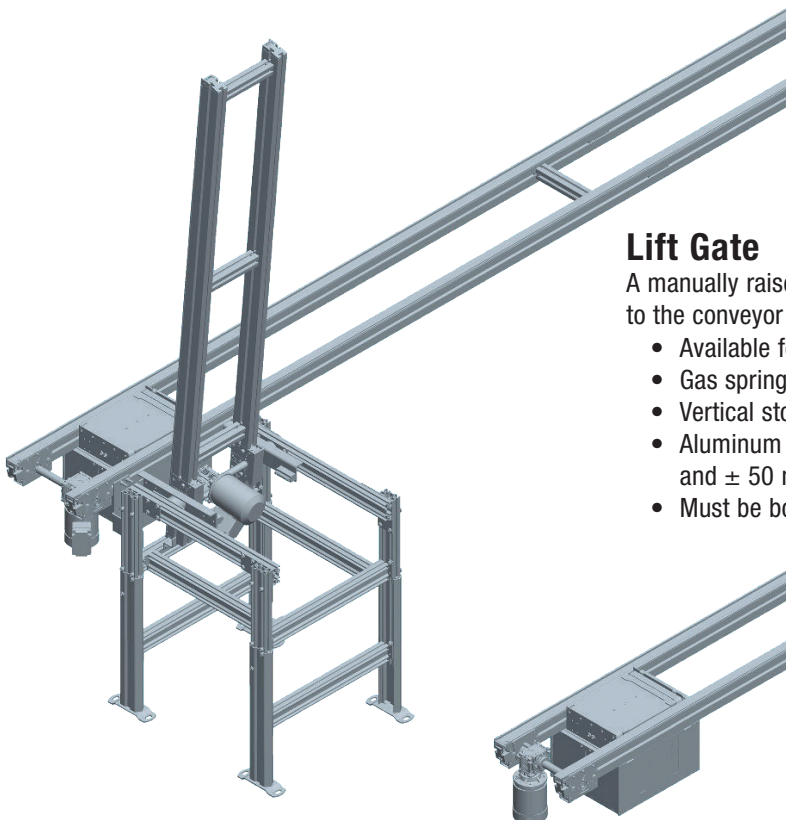

### Lift Gate

A manually raised and lowered conveyor section to allow access to the conveyor line

- Available for standard and custom pallet sizes
- Gas spring-controlled pivot mechanism
- Vertical stop position
- Aluminum support structure with T-slot construction and  $\pm 50$  mm (2 in) adjustability
- Must be bolted to the floor

## Regulatory Approvals:







### Conveyors:

All Dorner ERT150 standard conveyors are CE approved. CE approval follows the provisions of the following directives; Machine Directive 2006/42/EC, EU Low Voltage Directive 2006/95/EC, and EMC Directive 2004/108/EC. All conveyors are marked with the CE symbol on the Dorner serial number tag located on the conveyor frame. Contact the factory for the CE Declaration of Conformity.

All Dorner ERT150 standard conveyors (not including gearmotors and controllers) are designed and manufactured in accordance with the restrictions defined in the "Restriction of Hazardous Substances" directive, citation 2015/863/EU, commonly known as RoHS. All conveyors are marked with the RoHS symbols on the Dorner serial number tag located on the conveyor frame.

### Gearmotors and Controllers:

All Dorner ERT150 gearmotors and controllers carry one or more of the following approvals. Products are not covered by each approval. Please see the appropriate part number on the gearmotor and controller charts located in this manual. In addition, regulatory symbols are located on the product information tags located on the product.

	<p>CE marking on a product is a manufacturer's declaration that the product complies with the essential requirements of the relevant European health, safety and environmental protection legislation, in practice by the Product Directives. CE Marking on a product ensures the free movement of the product within the European Union (EU).</p>
	<p>This directive restricts (with exceptions) the use of six hazardous materials in the manufacture of various types of electronic and electrical equipment. It is closely linked with the Waste Electrical and Electronic Equipment Directive (WEEE) 2002/96/EC which sets collection, recycling and recovery targets for electrical goods and is part of a legislative initiative to solve the problem of huge amounts of toxic e-waste.</p>
	<p>The UL Recognized Component mark is for products intended to be installed in another device, system or end product. This Recognized Component Mark is for the United States only. When a complete product or system containing UL Recognized Components is evaluated, the end-product evaluation process can be streamlined.</p>
	<p>The UL Recognized Component mark is for products intended to be installed in another device, system or end product. This Recognized Component Mark is for the United States and Canada. When a complete product or system containing UL Recognized Components is evaluated, the end-product evaluation process can be streamlined.</p>
	<p>CSA International (Canadian Standards Association), is a provider of product testing and certification services for electrical, mechanical, plumbing, gas and a variety of other products. Recognized in the U.S., Canada and around the world, CSA certification marks indicate that a product, process or service has been tested to a Canadian or U.S. standard and it meets the requirements of an applicable CSA standard or another recognized document used as a basis for certification.</p>
	<p>The UL Listing Mark means UL found that representative product samples met UL's safety requirements. These requirements are primarily based on UL's own published standards for safety. The C-UL-US Mark indicates compliance with both Canadian and U.S. requirements. The products with this type of Mark have been evaluated to Canadian safety requirements and U.S. safety requirements.</p>

## Cleanroom Certifications:

ERT150 Conveyors are often used in Cleanroom applications where the generation of particulates from the conveyor are a concern. In these applications the correct installation and application of the conveyor is critical to the proper running of the conveyor and minimizing the dust generated by the conveyor.

ERT150 Conveyors are designed and constructed to be used in Cleanroom environments. The ERT150 Series conveyor has gone through third party testing and verification for use in ISO Standard 14644-1:2015 Class 4 and Federal Standard 209 Class 10 Cleanroom applications. Specifically, the conveyor tested was slip roller design with empty pallets accumulating for a period of 100 hours. Application specifics of duty cycle, weight, conveyor speeds and cleanroom conditions all may negatively affect cleanroom ratings. Specific results may vary.

Contact the factory for a copy of the test report.



TUV Tested and Verified for Cleanroom Class 4 Certification.

Test Report No.: 721667424-R1 Report Date: 4 November 2021		
<b>SUBJECT</b>	Airborne particle concentration Test for ERT150 Conveyor	
<b>TEST LOCATION</b>	TÜV SÜD China TÜV SÜD Products Testing (Shanghai) Co., Ltd. B-3/4, No.1999 Du Hui Road, Minhang District Shanghai 201108, P.R. China	
<b>CLIENT NAME</b>	Dorner Manufacturing Corp.	
<b>CLIENT ADDRESS</b>	975 Cottonwood Avenue Hartland, Wisconsin, USA	
<b>TEST PERIOD</b>	14-Oct-2021~25-Oct-2021	
<b>TEST REQUEST</b>	ISO 14644-1:2015 Cleanrooms and associated controlled environments - Part1:Classification of air cleanliness by particle concentration	
<b>Prepared By</b>		
	Shao Xiaomin (Shao Xiaomin) Report Drafter	 (Steven Zhang) Authorized Signatory
<b>TEST CONCLUSION</b>	The airborne particle concentration testing result complies with ISO Class 4 specified in ISO 14644-1:2015 when the conveyor was put in above mentioned laboratory testing condition.	

## Conveyor Noise Level (Decibel Ratings)

The actual noise level generated by the conveyor depends on several factors: the installation configuration, the product running on the conveyor, the surrounding equipment, the conveyor options and belt speed. The noise level generated by the conveyor is typically less than the general noise level of factory equipment.

The following charts provide basic decibel ratings for a typical conveyor arrangements.

### ERT150 Conveyors:

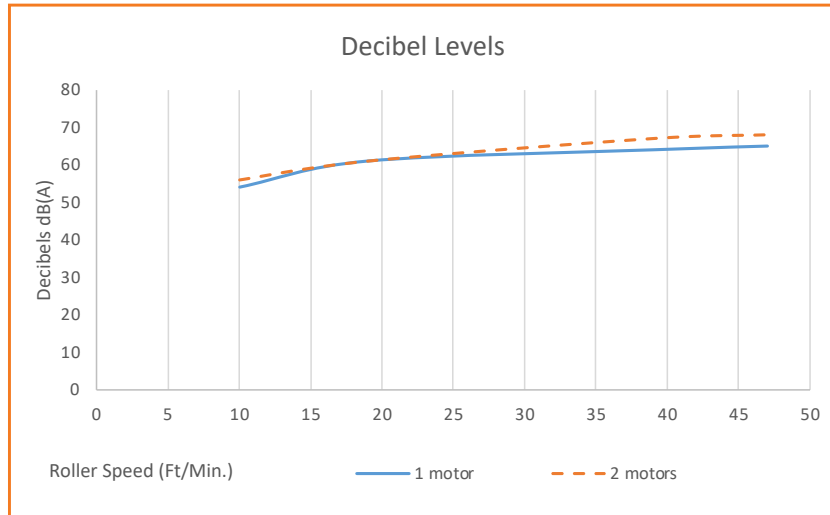

**Note:** Noise level taken after gear set break-in period. Initial decibel readings may be up to 15% higher.

## Calculating Conveyor Belt Speed

### ERT150 Conveyors:

To calculate the conveyor belt speed you need to know the following factors:

- Roller diameter: 24 mm (0.95 in)
- RPM of gearmotor

Note: All gearing in the ERT150 conveyor is 1.56:1 ratio (42 tooth/27 tooth)

Belt Speed:

$$(\text{ft/min}) = (\text{Drive roller diameter}/12) * (3.14) * (\text{RPM of gearmotor}) * (1.56)$$

$$(\text{m/min}) = (\text{Drive roller diameter, mm}/1000) * (3.14) * (\text{RPM of gearmotor}) * (1.56)$$

Example: ERT150 Conveyor and gearmotor. The gearmotor is a 33:1 ratio with 176 rpm output.

$$\text{Belt Speed (ft/min)} = (0.95/12) * (3.14) * (176) * (1.56)$$

$$\text{Belt speed (ft/min)} = 69 \text{ ft/min}$$

## Calculating Conveyor Load capacity

There are several factor(s) that effect the overall conveyor load of the ERT150 conveyor.

These include:

- Conveyor size and configuration
- Conveyor speed
- Application temperature
- Product accumulation
- Number of starts and stops per hour

Located online at [www.dornerconveyors.com](http://www.dornerconveyors.com) is the Dorner conveyor configuration tool, DTools. This tool allows you to configure your conveyor layout and determine the maximum load capacity for the conveyor. It is suggested that this program be used to calculate the conveyor load as the calculation is quite complicated. This configuration program however does not take into account temperature, dirty conditions, and conveyor starts and stops. If these conditions are part of your application please use the load reducing factors as shown below.

$$\text{Maximum Load} = (\text{Load from DTools})(\text{Temperature Factor})(\text{Start/Stop Factor})$$

Temperature Factor		
Ambient temperature can negatively affect the capacity of the conveyor.		
Temperature F	Temperature C	Temperature Factor
-4	-20	1.0
32	0	1.0
68	20	1.0
104	40	0.9
140	60	0.8

Start / Stop Factor	
Frequent Start / Stops of the conveyor can negatively affect the capacity of the conveyor. All start / stop applications must use a soft start mechanism such as a Frequency Inverter with a 1 second acceleration cycle.	
Application Condition	Start / Stop Factor
Continuous Run or 1 start/stop per hour	1.0
Maximum 10 starts/stop per hour	0.83
Maximum 30 starts/stop per hour	0.70
Greater than 30 starts/stop per hour	0.62

## ERT Pallet Weights kg (lbs)

ERT150 Pallet Weights					
Pallet Width (mm)	Pallet Length (mm)	1/4 in Alum Plate		3/8 in Alum Plate	
		kg.	lbs.	kg.	lbs.
160	160	1	2.1	1.2	2.6
160	240	1.2	2.7	1.5	3.4
200	200	1.2	2.7	1.6	3.5
240	160	1.2	2.7	1.5	3.4
240	240	1.6	3.6	2.1	4.7
240	320	2	4.5	2.7	6
280	280	2	4.5	2.7	6
320	240	2	4.5	2.7	6
320	320	2.5	5.6	3.5	7.6

## Automation Modules – Pneumatic Specifications

ERT150 Pneumatic Specifications								
Devise	Action	Bore Diameter	Stroke	Return Type	Force per Psi	Sensor Compatible	Fitting Tap Size	Fitting Tube Size
Lift & Locate	Lift cylinder	40 mm (1.6 in)	40 mm (1.6 in)	Pneumatic	1.9 lb	Yes	1/8 NPT	1/4 inch
Lift & Transfer	Lift cylinder	40 mm (1.6 in)	40 mm (1.6 in)	Pneumatic	1.9 lb	Yes	1/8 NPT	1/4 inch
Lift & Rotate	Lift cylinder, 320 to 400mm wide	40 mm (1.6 in)	40 mm (1.6 in)	Pneumatic	1.9 lb	Yes	1/8 NPT	1/4 inch
	Rotary Actuator 160-200	21 mm (0.8 in)	40 mm (1.6 in)	Pneumatic	.33 in lb	Yes	1/8 NPT	1/4 inch
	Rotary Actuator 240-320	25 mm (1 in)	69 mm (2.7 in)	Pneumatic	.56 in lb	Yes	1/8 NPT	1/4 inch
Turn and Transfer	Rotary Actuator	32 mm (1.3 in)	93 mm (3.7 in)	Pneumatic	1.2 in lb	Yes	1/8 NPT	1/4 inch
Pallet Pusher	Pusher cylinder 160	20 mm (0.8 in)	200 mm (7.9 in)	Pneumatic	0.5 lb	Yes	1/8 NPT	1/4 inch
	Pusher cylinder 200	20 mm (0.8 in)	210 mm (8.3 in)	Pneumatic	0.5 lb	Yes	1/8 NPT	1/4 inch
	Pusher cylinder 240	20 mm (0.8 in)	250 mm (9.8 in)	Pneumatic	0.5 lb	Yes	1/8 NPT	1/4 inch
	Pusher cylinder 280	20 mm (0.8 in)	290 mm (11.4 in)	Pneumatic	0.5 lb	Yes	1/8 NPT	1/4 inch
	Pusher cylinder 320	20 mm (0.8 in)	330 mm (13 in)	Pneumatic	0.5 lb	Yes	1/8 NPT	1/4 inch
Pallet Stop, Cushioned	Light Load, Retract	35 mm (1.4 in)	9 mm (0.35 in)	Spring	n/a	No	GM5	1/4 inch
	Light Load, Retract	35 mm (1.4 in)	9 mm (0.35 in)	Spring	n/a	No	GM5	1/4 inch
Pallet Stop, Non-Cushioned	Standard Load, Retract	35 mm (1.4 in)	9 mm (0.35 in)	Spring	n/a	No	GM5	1/4 inch

Dimensions = mm (in)



## ERT150 Module Spacing Guidelines

Pallet Stop to Lift & Locate to Lift & Locate Spacing			
Pallet Length	Minimum Distance D1	Minimum Distance D2	Minimum Distance D3
160 (6.3)	85 (3.3)	380 (15)	260 (10.2)
200 (7.9)	105 (4.1)	420 (16.5)	300 (11.8)
240 (9.4)	125 (4.9)	460 (18.1)	340 (13.4)
280 (11)	145 (5.7)	500 (19.7)	380 (15)
320 (12.6)	165 (6.5)	540 (21.3)	420 (16.5)

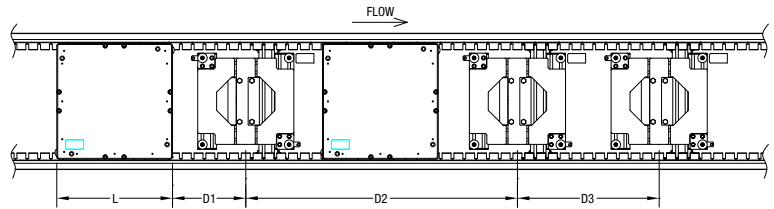

Pallet Stop to Lift & Transfer to Lift & Transfer Spacing			
Pallet Length*	Minimum Distance D1	Minimum Distance D2	Minimum Distance D3
160 (6.3)**	260 (10.2)	560 (22)	400 (15.7)
200 (7.9)**	310 (12.2)	670 (26.4)	460 (18.1)
240 (9.4)**	350 (13.8)	840 (33.1)	550 (21.7)
280 (11)	210 (8.3)	700 (27.6)	400 (15.7)
320 (12.6)	230 (9.1)	740 (29.1)	420 (16.5)

\*Note: Information provided is for square pallet sizes. For rectangular pallets, consult factory.

\*\*Note: 160 mm, 200 mm and 240 mm lift and transfers include integrated infeed conveyor.

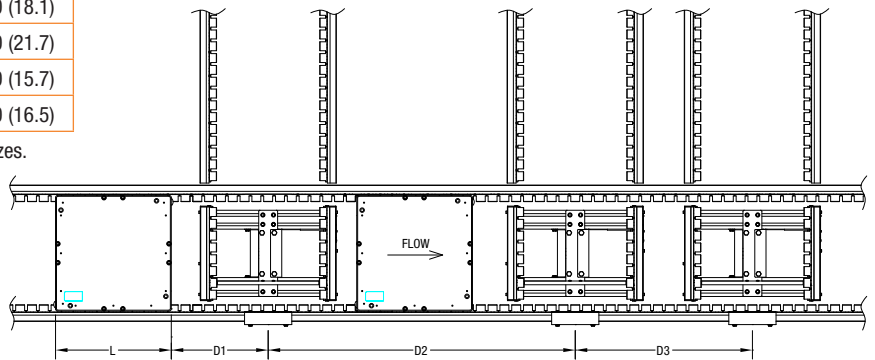

Parallel Conveyors with Lift & Transfer		
Pallet Width*	Minimum Distance X	Minimum Distance Y
160 (6.3)**	400 (15.7)	128 (5)
200 (7.9)**	440 (17.3)	128 (5)
240 (9.4)**	480 (18.9)	128 (5)
280 (11)	520 (20.5)	128 (5)
320 (12.6)	560 (22)	128 (5)

\*Note: Information provided is for square pallet sizes. For rectangular pallets, consult factory.

\*\*Note: 160 mm, 200 mm and 240 mm lift and transfers include integrated infeed conveyor.

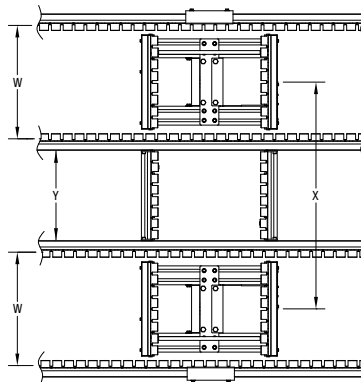

Dimensions = mm (in)

**ERT150 Module Spacing Guidelines** *Continued*

Parallel Conveyors with Two Turn & Transfer with a Transfer Conveyor					
Pallet Length (mm)	Pallet Length (mm)	Turn & Transfer Diameter X mm (in)	Distance D1 minimum mm (in)	Distance D2 mm (in)	Distance D3 minimum mm (in)
160	160	270 (10.6)	358 (14.1)	140 (5.5)	128 (5)
160	240	320 (12.6)	394 (15.5)	158 (6.2)	128 (5)
200	200	320 (12.6)	394 (15.5)	158 (6.2)	128 (5)
240	160	370 (14.6)	430 (16.9)	176 (6.9)	128 (5)
240	240	370 (14.6)	430 (16.9)	176 (6.9)	128 (5)
240	320	420 (16.5)	464 (18.3)	193 (7.6)	128 (5)
280	280	420 (16.5)	464 (18.3)	193 (7.6)	128 (5)
320	240	470 (18.5)	500 (19.7)	211 (8.3)	128 (5)
320	320	470 (18.5)	500 (19.7)	211 (8.3)	128 (5)

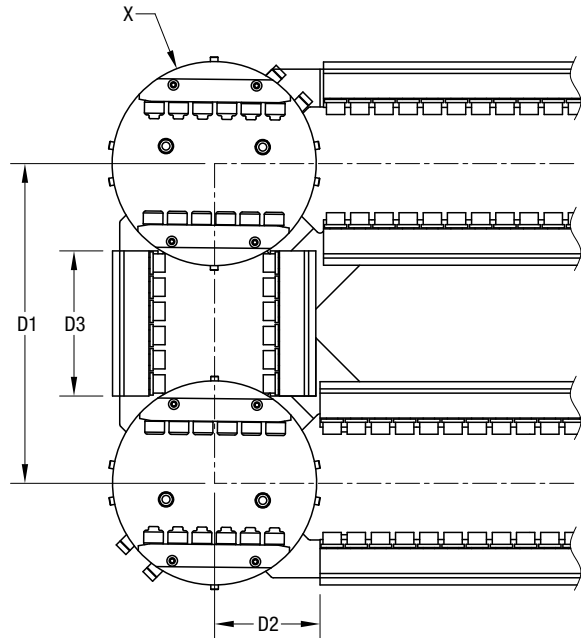

Dimensions = mm (in) Note: All dimensions assume square pallets

### ERT150 Pallet Plate Details Dimensions

The following details are for standard square pallets only. For other size pallets contact Dorner.

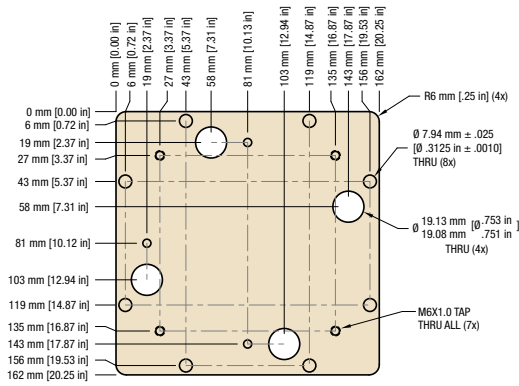

**160 x 160**

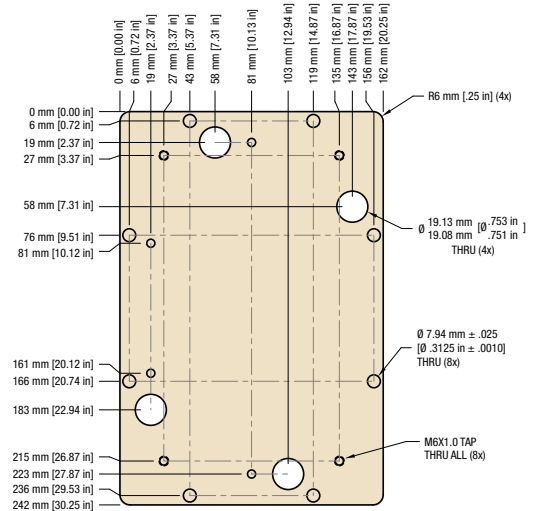

**160 x 240**

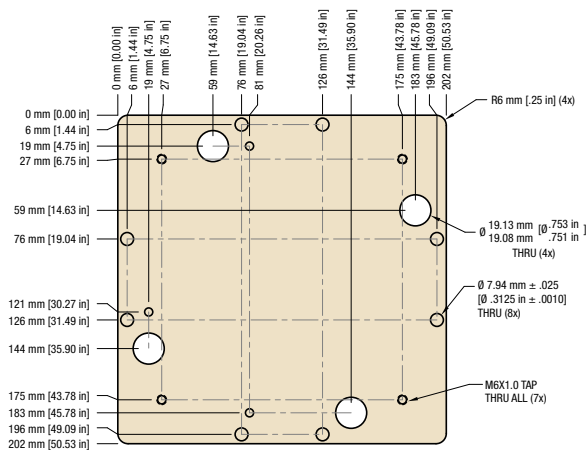

**200 x 200**

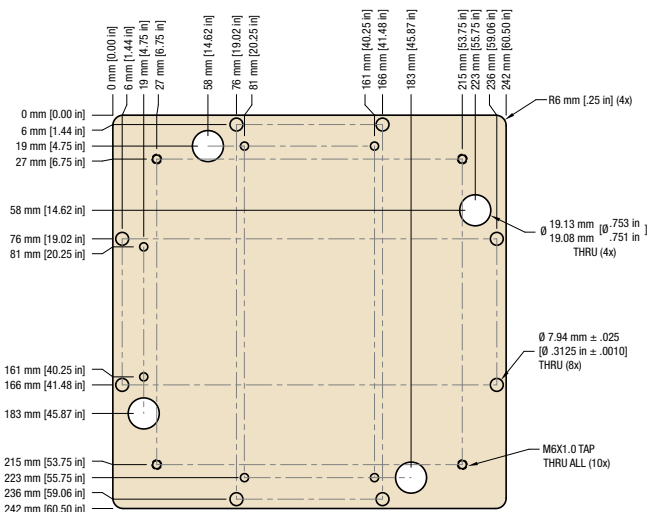

**240 x 240**

### ERT150 Pallet Plate Details Dimensions *Continued*

The following details are for standard square pallets only. For other size pallets contact Dorner.

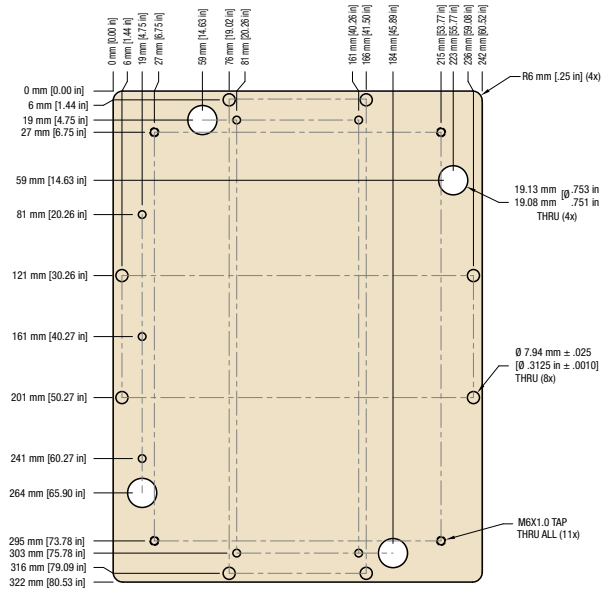

**240 x 320**

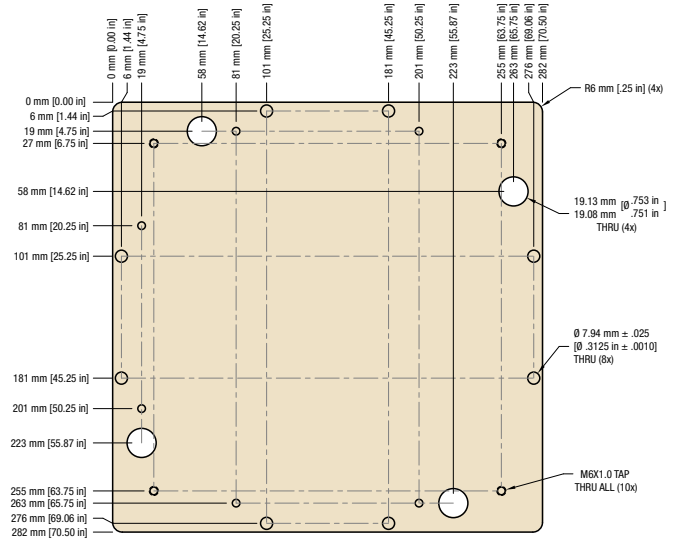

**280 x 280**

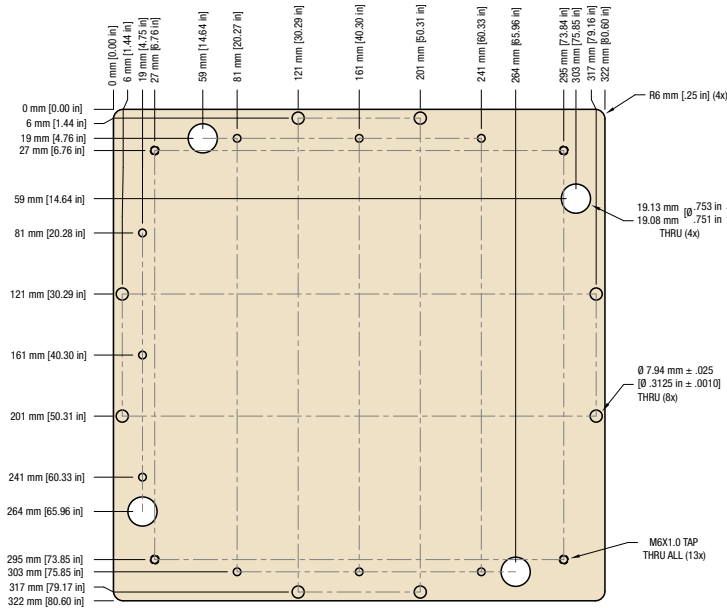

**320 x 320**

## ERT150 Conveyors are best for:

- Pallet & Tray Handling
- No & Low Back Pressure Accumulation
- Cleanroom Applications
- Small and Light-Load Assembly Automation
- Medical Product Manufacturing
- Packaging
- Medical Device Manufacturing
- Electronic & Consumer Goods Assembly

### Sizes & Measurements

- Width from 80 mm to 480 mm
- Lengths from 128 mm to 2432 mm (in 64 mm increments)
- 24 mm diameter rollers on 32 mm centers

### Slip & Driven Rollers



Driven Roller



Slip Roller

### Loads & Speeds

- Loads: up to 16 kg (35 lbs) per pallet or tray
- Speeds: up to 37 m/min (121 ft/min)

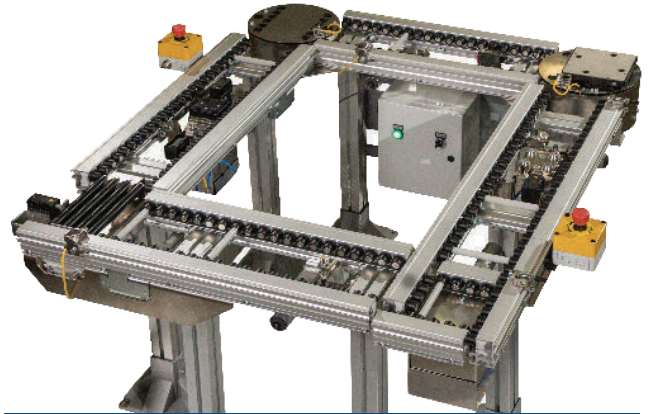

### Slide Rail Options

Aluminum frame with two T-slot options



T-slot Rail



Flush Side Rail (Cleanroom)

### Pallets

- 160 mm to 320 mm pallets
- Static conductive HPDE skirt
- Proximity sensor pick-up on side and bottom
- Dimensionally compatible with industry standards

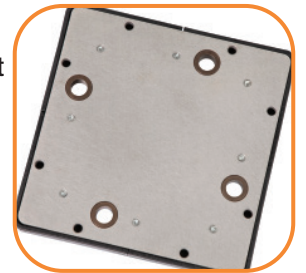

### Modules

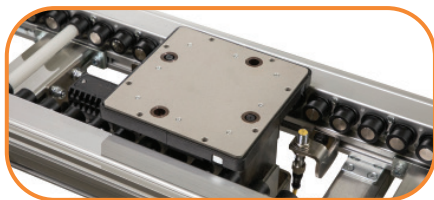

Lift & Locate



Lift & Rotate

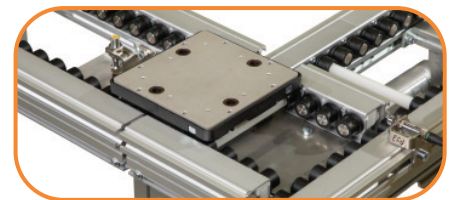

Lift & Transfer

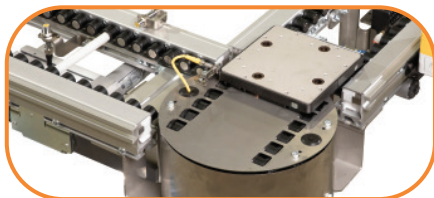

Turn & Transfer

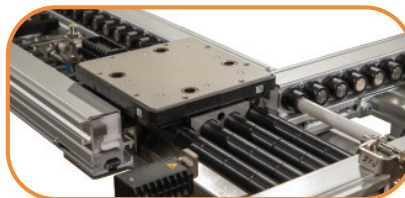

Pallet Pusher



Pallet Stops

### Industrial Conveyors

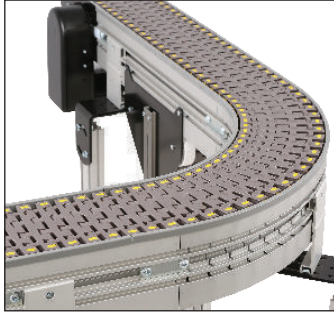
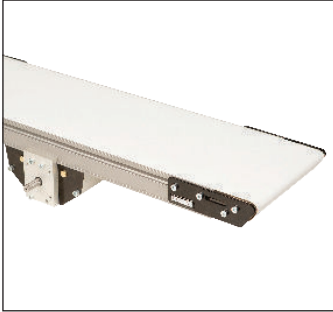

### Sanitary Conveyors

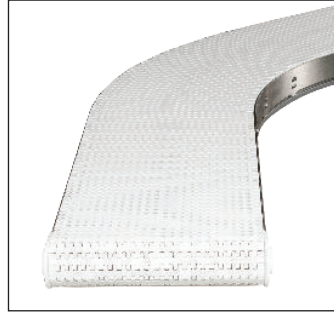
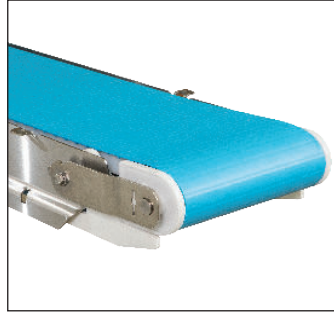

### Pallet Systems

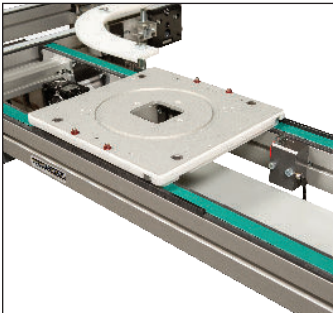

### Flexible Conveyance

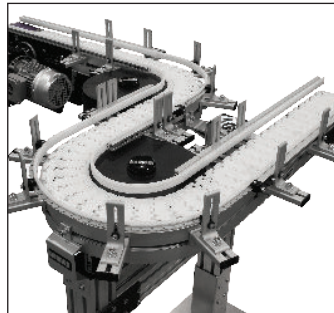

### Parts & Service



### Engineered Solutions

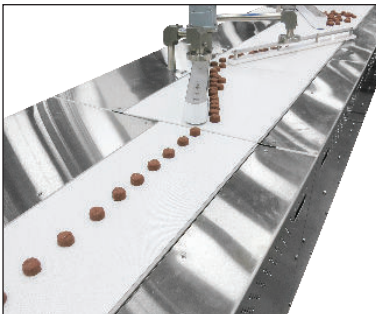

### Online Configurator



### Warranty

